

APPENDIX A

COST ANNUALIZATION MODEL

Figures A-1 and A-2 provide an overview of the cost annualization model as used for analysis of the proposed rule, and as will be used for analysis of the final rule respectively. Inputs to the model differ in each analysis because for the analysis of the final rule, data from the 2001 Meat Products Industry Survey detailed questionnaire will be used in addition to other data from the proposal analysis. The inputs for proposal include the capital and operating and maintenance (O&M) costs for incremental pollution control developed by EPA, and a variety of secondary sources. The cost annualization model calculates four types of compliance costs for a site:

- Present value of expenditures — before-tax basis
- Present value of expenditures — after-tax basis
- Annualized cost — before-tax basis
- Annualized cost — after-tax basis

There are two reasons why the capital and O&M costs should be annualized. First, the initial capital outlay should not be compared against a site's income in the first year because the capital cost is incurred only once in the equipment's lifetime. That initial investment should be spread over the equipment's life. Second, money has a time value. A dollar today is worth more than a dollar in the future; expenditures incurred 15 years from now do not have the same value to the firm as the same expenditures incurred tomorrow.

The cost annualization model is defined in terms of 1999 dollars because the latest year for which financial data will be available from the detailed survey is 1999. Pollution control capital and O&M costs are estimated in 1999 dollars and used to project cash outflows. The cash outflows are then discounted to calculate the present value of future cash outflows in terms of 1999 dollars. This methodology evaluates what a business would pay in constant dollars for all initial and future expenditures. Finally, the model

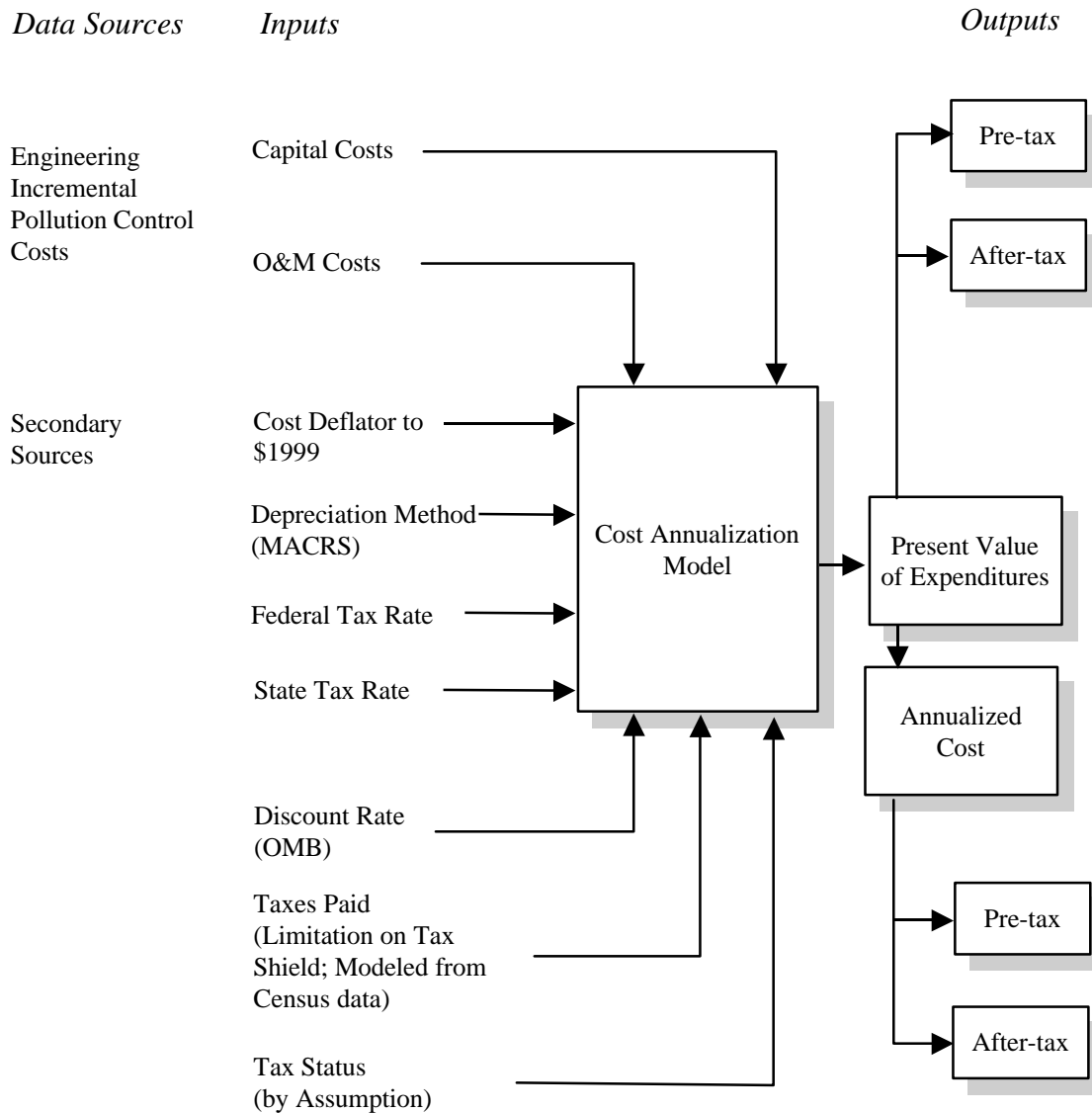

Figure A-1

Cost Annualization Model for the Proposal Analysis

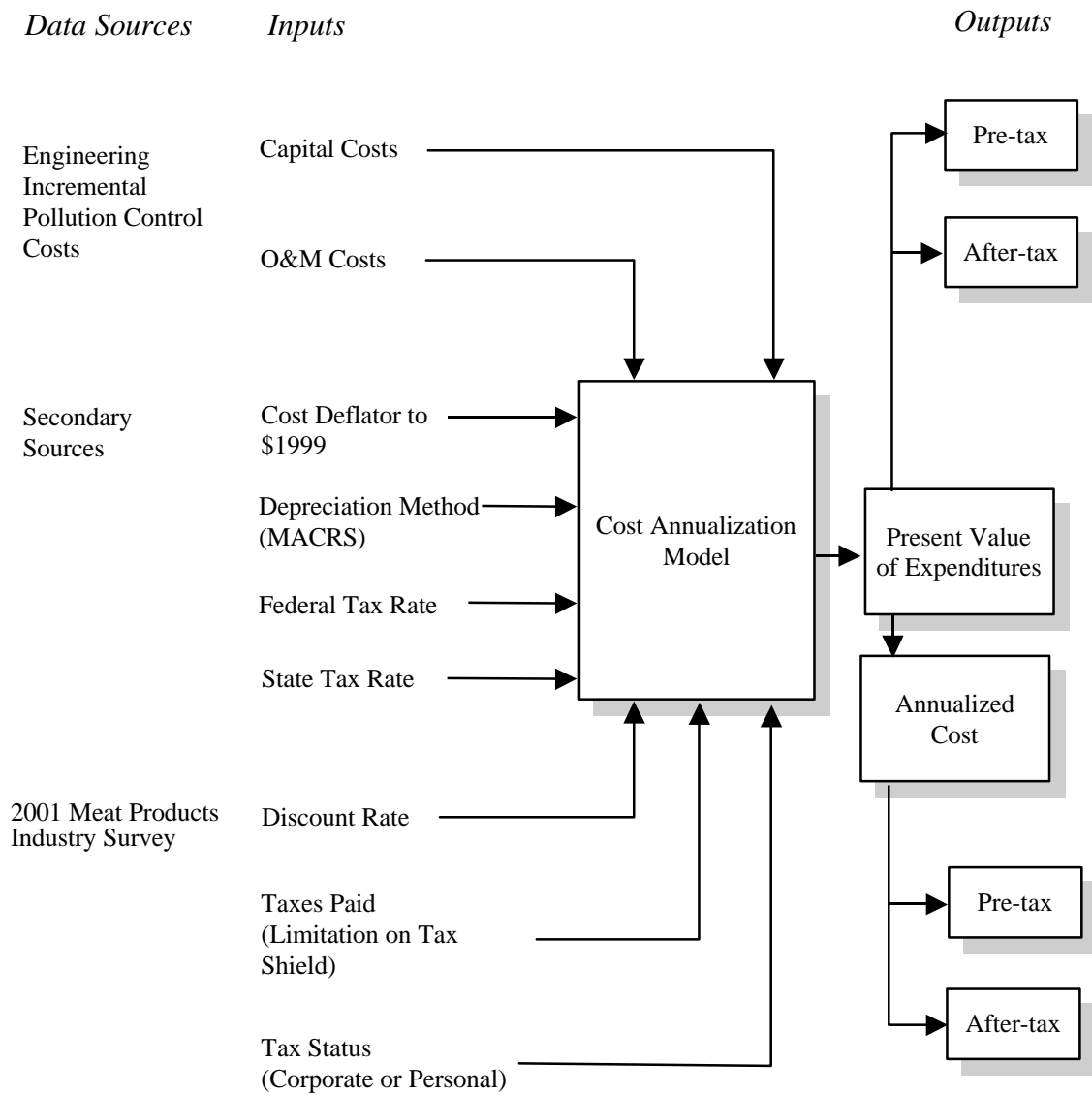

Figure A-2

Cost Annualization Model for the Final Analysis

calculates the annualized cost for the cash outflow as an annuity that has the same present value of the cash outflows and includes the cost of money or interest. The annualized cost is analogous to a mortgage payment that spreads the one-time investment of a home into a defined series of monthly payments.

Section A.1 discusses the data sources for inputs to the cost annualization model for the proposal analysis as well as the final analysis. Section A.2 summarizes the financial assumptions in the model. Section A.3 presents all steps of the model with a sample calculation.

A.1 INPUT DATA SOURCES

A.1.1 EPA Engineering Cost Estimates

The *capital and O&M* costs used in the cost annualization model are developed by EPA's engineering staff. The capital cost is the initial investment needed to purchase and install the equipment; it is a one-time cost. The O&M cost is the annual cost of operating and maintaining the equipment. O&M costs are incurred every year of the equipment's operation. For proposal, EPA estimated average compliance costs for a series of model facilities based on subcategory, size, and discharge type (for details see Development Document, U.S. EPA, 2002). For the final rule, EPA will use model facilities developed from detailed questionnaire data.

A.1.2 Secondary Data

The cost annualization model is developed in terms of constant 1999 dollars. Hence, as necessary, all costs are deflated to 1999 dollars for the cost annualization model using a *cost deflator*. As mentioned above, engineering cost estimates are already in 1999 dollars. However, in the proposal analysis, income measures and the variance of their distributions were derived from Census data in 1997 dollars and need to be adjusted. EPA calculated the implicit price deflator for Food and Kindred Products from Bureau of Economic Analysis' Gross Domestic Product by Industry data (U.S. DOC, 2000). For analysis of the final rule, income measures and other survey data will be in 1999 dollars.

The *depreciation method* used in the cost annualization model is the Modified Accelerated Cost Recovery System (MACRS). MACRS allows businesses to depreciate a higher percentage of an investment in the early years and a lower percentage in the later years.

Tax rates are determined by the Federal tax rate plus the national average state tax rate. Table A-1 presents the Federal tax rate for corporations and individuals (CCH, 1999b). The Federal tax rate is calculated from a graduated system with a tax rate for each level of taxable income. Table A-2 lists each state's top corporate and individual tax rates and calculates national average state tax rates (CCH, 1999a). The cost annualization model uses the average state tax rate because of the complexities of the industry; for example, a site could be located in one state, while its corporate headquarters are located in a second state. Given the uncertainty over which state tax rate applies to a given site's revenues, the average state tax rate — rounded to three decimal points — is used in the cost annualization model for all sites (i.e., 6.6 percent corporate tax rate and 5.6 percent personal tax rate).

For the proposal analysis, taxable income — earnings before interest and taxes (EBIT) — is derived from Census data. Derivation of EPA's estimate of EBIT for model facilities is discussed in more detail in Appendix B. For the final analysis, EPA will use the value of EBIT reported in the survey. The value of EBIT determines the tax bracket for the site.

The cost annualization model incorporates variable tax rates according to the level of income to address differences between small and large businesses. For example, a large business might have a combined tax rate of 40.6 percent (34 percent Federal plus 6.6 percent State). After tax shields, the business would pay 59.4 cents for every dollar of incremental pollution control costs. A small business, say a small sole proprietorship, might be in the 20.8 percent tax bracket (15 percent Federal plus 5.8 percent State). After tax shields, the small business would pay 79.2 cents for every dollar of incremental pollution control. The net present value of after-tax cost is used in the closure analysis because it reflects the long-term impact on its income the business would actually experience.

The *discount rate* is the minimum rate of return on capital required to compensate debt holders and equity owners for bearing risk. It is also called the marginal weighted average cost of capital or the

**Table A-1
Federal Tax Table**

Corporate Tax Rate		Individual Tax Rate	
Taxable Income (\$1,000)	Average Effective Tax Rate	Taxable Income (\$1,000)	Average Effective Tax Rate
\$0 - \$50	15%	\$0 - \$25.75	15%
\$50 - \$75	25%	\$25.75 - \$62.45	28%
\$75 - \$100	34%	\$62.45 - \$130.25	31%
\$100 - \$335	34% *	\$130.25 - \$283.15	36%
\$335 - \$10,000	34%	More than \$283.15	40%
\$10,000 - \$15,000	35%		
\$15,000 - \$18,333	35% *		
More than \$18,333	35%		

Source: CCH, 1999b. 2000 U.S. Master Tax Guide. Chicago, IL: CCH.

* For the \$100,000 to \$335,000 taxable income range, the actual tax rate is 38% and for taxable income between \$15,000,000 and \$18,333,333, the actual rate is 39%. However, these rates were temporarily imposed to phase out certain benefits and hence, are not used here.

**Table A-2
State Income Tax Rates**

State	Corporate Income Tax Rate	Basis for States		
		With Graduated Tax Tables	Personal Income Tax Upper Rate	With Graduated Tax Tables
Alabama	5.00%		5.00%	\$3,000+
Alaska	9.40%	\$90,000+	0.00%	
Arizona	8.00%		5.04%	\$150,000+
Arkansas	6.50%	\$100,000+	7.00%	\$25,000+
California	6.65%		9.30%	\$47,000
Colorado	4.75%		4.75%	
Connecticut	7.50%		4.50%	\$10,000+
Delaware	8.70%		6.40%	\$60,000+
Florida	5.50%		0.00%	
Georgia	6.00%		6.00%	\$10,000+
Hawaii	6.40%	\$100,000+	8.75%	\$40,000+
Idaho	8.00%		8.20%	\$20,000+
Illinois	4.80%		3.00%	
Indiana	3.40%		3.40%	
Iowa	12.00%	\$250,000+	8.98%	\$52,000+
Kansas	4.00%		6.45%	\$30,000+
Kentucky	8.25%	\$250,000+	6.00%	\$8,000+
Louisiana	8.00%	\$200,000+	6.00%	\$50,000+
Maine	8.93%	\$250,000+	8.50%	\$33,000+
Maryland	7.00%		4.80%	\$3,000+
Massachusetts	9.50%		5.95%	
Michigan	2.20%		4.40%	
Minnesota	9.80%		8.00%	\$50,000+
Mississippi	5.00%	\$10,000+	5.00%	\$10,000+
Missouri	6.25%		6.00%	\$9,000+
Montana	6.75%		11.00%	\$71,000+
Nebraska	7.81%	\$50,000+	6.99%	\$27,000+
Nevada	0.00%		0.00%	
New Hampshire	8.00%		0.00%	
New Jersey	7.25%		6.37%	\$75,000+
New Mexico	7.60%	\$1Million+	8.20%	\$42,000+
New York	7.50%		6.85%	\$20,000+
North Carolina	7.50%		7.75%	\$60,000+
North Dakota	10.50%	\$50,000+	12.00%	\$50,000+
Ohio	8.50%	\$50,000+	7.30%	\$200,000+
Oklahoma	6.00%		7.00%	

**Table A-2 (cont.)
State Income Tax Rates**

State	Corporate Income Tax Rate	Basis for States		
		With Graduated Tax Tables	Personal Income Tax Upper Rate	With Graduated Tax Tables
Oregon	6.60%		9.00%	\$5,000+
Pennsylvania	9.99%		2.80%	
Rhode Island *	9.00%		10.40%	\$250,000+
South Carolina	5.00%		7.00%	\$12,000+
South Dakota	6.00%		0.00%	
Tennessee	6.00%		0.00%	
Texas	0.00%		0.00%	
Utah	5.00%		7.00%	\$7,500+
Vermont *	9.75%	\$250,000+	9.45%	\$250,000+
Virginia	6.00%		5.75%	\$17,000+
Washington	0.00%		0.00%	
West Virginia	9.00%		6.50%	\$60,000+
Wisconsin	7.90%		6.77%	\$15,000+
Wyoming	0.00%		0.00%	
Average:	6.58%		5.59%	

Source: CCH, 1999a. 2000 State Tax Handbook. Chicago, IL: CCH.

Basis for rates is reported to nearest \$1,000.

* Personal income tax rates for Rhode Island and Vermont based on federal tax (not taxable income).

+ Tax rates given here are equivalents for highest personal federal tax rate.

weighted average of debt and equity rates. The discount rate is used to calculate the present value of the cash flows. As recommended by the Office of Management and Budget (OMB), for the proposal analysis, a real discount rate of 7 percent is used to represent the opportunity cost of capital (OMB, 1996). For the final analysis, the discount rate for each site will be obtained from the survey data. For sites that do not report a discount rate, EPA will assign the median discount rate as the opportunity cost of capital.

Average taxes paid is used to limit the tax shield to the typical amount of taxes paid in any given year. For the proposal analysis, it is calculated as the amount of tax paid in 1999 by the model facility (see Appendix B for more detail). In the final analysis, average taxes paid will be calculated from the 1997, 1998, and 1999 taxes paid by the site.

Corporate structure is used for the purpose of estimating tax shields on expenditures. A C corporation pays federal and state taxes at the corporate rate. An S corporation or a limited liability corporation distributes earnings to the partners and the individuals pay the taxes. For the purpose of the proposal analysis, EPA assumes that all model facilities pay federal and state taxes at the corporate rate. In the final analysis, EPA will distinguish corporate structure based on detailed survey data. The tax rate for S corporations and limited liability corporations will be presumed to be zero.¹ All other entities will be assumed to pay taxes at the individual rate.

A.2 FINANCIAL ASSUMPTIONS

The cost annualization model incorporates several financial assumptions:

¹ The effect of this assumption is to assume there is no tax shield for S corporations and limited liability corporations (LLCs). S corporations and LLCs will see no change in tax shield benefit because they do not pay taxes. The persons to whom the income is distributed, however, will see the change in earnings due to incremental pollution control costs; there is no tax shield benefit.

- Depreciation method is the Modified Accelerated Cost Recovery System (MACRS).² MACRS applies to assets put into service after December 31, 1986. MACRS allows businesses to depreciate a higher percentage of an investment in the early years and a lower percentage in the later years.
- There is a six-month lag between the time of purchase and the time operation begins for the pollution control equipment. A mid-year depreciation convention may be used for equipment that is placed in service at any point within the year (CCH, 1999b, ¶1206). EPA chose to use a mid-year convention in the cost annualization model because of its flexibility and the likelihood that the equipment considered for pollution control could be built and installed within a year of initial investment. Because a half-year of depreciation is taken in the first year, a half-year needs to be taken in the 16th year of operation. Consequently, the cost annualization model spans a 16-year time period.
- The pollution equipment has an operating lifetime or class life between 20 and 25 years. It is considered 15-year property.

The depreciable life of the asset is based on, but is not equivalent to, the useful life of the asset. The Internal Revenue Service (IRS) establishes different “classes” of property. For example, a race horse is 3-year property. The Internal Revenue Code Section 168 classifies an investment as 15-year property if it has a class life of 20 years or more but less than 25 years. Section 168(e)(3)(E) lists a municipal wastewater treatment plant as an example of 15-year property (CCH, 1999b, ¶1240; RIA, 1999). The cost annualization model, therefore, incorporates a 15-year depreciable lifetime. Thus, for the purpose of the calculating depreciation, most components of the pollution control capital costs considered in this analysis

² EPA examined straight-line depreciation, Internal Revenue Code Section 169 and 179 provisions as well as MACRS for depreciation. Straight-line depreciation writes off a constant percentage of the investment each year. MACRS offers companies a financial advantage over the straight-line method because a company's taxable income may be reduced under MACRS by a greater amount in the early years when the time value of money is greater.

Section 169 provides an option to amortize pollution control equipment over a 5-year period (RIA, 1999). Under this provision, 75 percent of the investment could be rapidly amortized in a 5-year period using a straight-line method. The 75 percent figure is based on the ratio of allowable lifetime (15 years) to the estimated usable lifetime (20 years) as specified in Section 169, Subsection (f). Although the tax provision enables the site to expense the investment over a shorter time period, the advantage is substantially reduced because only 75 percent of the capital investment can be recovered. Because the benefit of the provision is slight and sites might not get the required certification to take advantage of it, the provision was not included in the cost annualization model.

EPA also considered the Section 179 provision to elect to expense up to \$24,000 if the equipment is placed into service in 2001 or 2002 (RIA, 1999). The deduction increased to \$25,000 if the equipment is placed into service in 2003 or later. EPA assumes that this provision is applied to other investments for the business entity. Its absence in the cost annualization model may result in a slightly higher estimate of the after-tax annualized cost for the site.

would be 15-year property. According to IRS requirements, pollution control equipment can be depreciated, but the total cost of the equipment cannot be subtracted from income in the first year. In other words, the equipment must be capitalized, not expensed (CCH, 1999b, ¶991; and RIA, 1999, Section 169).

A.3 SAMPLE COST ANNUALIZATION SPREADSHEET

In Table A-3, the spreadsheet contains numbered columns that calculate the before- and after-tax annualized cost of the investment to the site. The first column lists each year of the equipment's life span, from its installation through its 15-year depreciable lifetime.

Column 2 represents the percentage of the capital costs that can be written off or depreciated each year. These rates are based on the MACRS and are taken from CCH (1999b). Multiplying these depreciation rates by the capital cost gives the annual amount the site may depreciate, which is listed in Column 3. Depreciation expense is used to offset annual income for tax purposes; Column 4 shows the potential tax shield provided from the depreciation expense—the overall tax rate times the depreciation amount for the year.

Column 5 is the annual O&M expense. In this example, Year 1 shows six months of O&M ($\$10,000 \div 2 = \$5,000$). Year 1 and Year 16 show only six months of O&M expenses because of the mid-year convention assumption for depreciation. For Years 2 through 15, O&M is a constant amount. Column 6 is the potential tax shield or benefit provided from expensing the O&M costs.

Column 7 lists a site's annual pre-tax cash outflow or total expenses associated with the additional pollution control equipment. Total expenses include capital costs, assumed to be incurred during the first year when the equipment is installed, plus each year's O&M expense.

Column 8 is the adjusted tax shield. The potential tax shield is the sum of the tax shields from depreciation (Column 4) and O&M/one-time costs (Column 6). If the potential tax shield for any year exceeds the 3-year average taxes paid, the tax shield is limited to the average taxes paid by the facility. In Table A-3 example, the potential tax shield in Year 2 is $\$2,052$ plus $\$2,160 = \$4,212$. This exceeds the

**Table A-3
Cost Annualization Model**

INPUTS							INPUTS	
Survey ID #:	999						surv_id	999
Option Number:							disc_rate	7.00%
Initial Capital Cost (\$):	\$100,000						corp_tax	1
Annual Operation & Maintenance Cost (\$):	\$10,000						ebit	\$23,000
Real Discount Rate:	7.0%						tax_99	\$2,333
Corporate Tax Structure	1						opt_cap	\$100,000
EBIT	\$23,000						opt_om	\$10,000
1999 Taxes Paid	\$2,333							
Marginal Income Tax Rates:								
Federal	15.0%							
State	6.6%							
Combined	21.6%							

Federal Corp.Tax Table:		Federal Individual Tax Table:	
Taxable Income	Average Effective Tax Rate	Taxable Income	Average Effective Tax Rate
\$0	15.0%	\$0	15.0%
\$50,000	25.0%	\$25,750	28.0%
\$75,000	34.0%	62450	31.0%
\$100,000	34.0%	130250	36.0%
\$335,000	34.0%	283150	39.6%
\$10,000,000	35.0%		

**Table A-3 (cont.)
Cost Annualization Model**

Column 1	2	3	4	5	6	7	8	9	
	Year	Depreciation Rate	Depreciation For Year	Tax Shield From Depreciation	O&M Cost	O&M Tax Shield	Cash Outflow	Adjusted Tax Shield	Cash Outflow After Tax Shields
	1	5.00%	\$5,000	\$1,080	\$5,000	\$1,080	\$105,000	\$2,160	\$102,840
	2	9.50%	\$9,500	\$2,052	\$10,000	\$2,160	\$10,000	\$2,333	\$7,667
	3	8.55%	\$8,550	\$1,847	\$10,000	\$2,160	\$10,000	\$2,333	\$7,667
	4	7.70%	\$7,700	\$1,663	\$10,000	\$2,160	\$10,000	\$2,333	\$7,667
	5	6.93%	\$6,930	\$1,497	\$10,000	\$2,160	\$10,000	\$2,333	\$7,667
	6	6.23%	\$6,230	\$1,346	\$10,000	\$2,160	\$10,000	\$2,333	\$7,667
	7	5.90%	\$5,900	\$1,274	\$10,000	\$2,160	\$10,000	\$2,333	\$7,667
	8	5.90%	\$5,900	\$1,274	\$10,000	\$2,160	\$10,000	\$2,333	\$7,667
	9	5.91%	\$5,910	\$1,277	\$10,000	\$2,160	\$10,000	\$2,333	\$7,667
	10	5.90%	\$5,900	\$1,274	\$10,000	\$2,160	\$10,000	\$2,333	\$7,667
	11	5.91%	\$5,910	\$1,277	\$10,000	\$2,160	\$10,000	\$2,333	\$7,667
	12	5.90%	\$5,900	\$1,274	\$10,000	\$2,160	\$10,000	\$2,333	\$7,667
	13	5.91%	\$5,910	\$1,277	\$10,000	\$2,160	\$10,000	\$2,333	\$7,667
	14	5.90%	\$5,900	\$1,274	\$10,000	\$2,160	\$10,000	\$2,333	\$7,667
	15	5.91%	\$5,910	\$1,277	\$10,000	\$2,160	\$10,000	\$2,333	\$7,667
	16	2.95%	\$2,950	\$637	\$5,000	\$1,080	\$5,000	\$1,717	\$3,283
	Sum	100.00%	\$100,000	\$21,600	\$150,000	\$32,400	\$250,000		\$213,461
	Present Value		\$65,856	\$14,225	\$94,267	\$20,362	\$194,267		\$171,081
							W/20 year life:		
				After Tax Shield		Before Tax Shield			
				\$171,081		\$194,267			
				\$18,110		\$20,565			

Notes: This spreadsheet assumes that a modified accelerated cost recovery system (MACRS) is used to depreciate capital expenditures. Depreciation rates are from 1995 U.S. Master Tax Guide for 15-year property and mid-year convention. First Year is not discounted.

average taxes paid over the last three years (\$2,333) and hence, the tax shield for Year 2 is \$2,333. This approach is conservative in that the limit is applied every year when a company may opt to carry losses forward to decrease tax liabilities in future years. An alternative approach is to limit the present value of the tax shield to the present value of taxes paid for the 15-year period. Should the first approach appear to overestimate cost impacts, the second approach may be examined as a sensitivity analysis.

Column 9 lists the annual cash outflow less the adjusted tax shield (Column 7 minus Column 8); a site will recover these costs in the form of reduced income taxes. The sum of the 16 years of after-tax expenses is \$250,000 (1999 dollars), i.e., the sum of the capital expense (\$100,000) and 15 years of O&M (\$150,000). The present value of these payments is \$194,267. The present value calculation takes into account the time value of money and is calculated as:

$$\text{Present Value of Cash Outflows} = \sum_{i=1}^n \frac{\text{cash outflow, year}_i}{(1 + \text{real discount rate})^{i-1}}$$

The exponent in the denominator is $i-1$ because the real discount rate is not applied to the cash outflow in Year 1. The present value of the after-tax cash outflow is used in the closure analysis to calculate the post-regulatory present value of future earnings for a site.

The present value of the cash outflow is transformed into a constant annual payment for use as the annualized site compliance cost. The annualized cost is calculated as a 16-year annuity that has the same present value as the total cash outflow in Column 9. The annualized cost represents the annual payment required to finance the cash outflow after tax shields. In essence, paying the annualized cost each year and paying the amounts listed in Column 8 for each year are equivalent. The annualized cost is calculated as:

$$\text{Annualized Cost} = \text{Present value of cash outflows} \times \frac{\text{real discount rate}}{1 - (\text{real discount rate} + 1)^{-n}}$$

where n is the number of payment periods. In this example, based on the capital investment of \$100,000, O&M costs of \$10,000 per year, a tax rate of 21.6 percent, and a real discount rate of 7 percent, the site's annualized cost is \$20,565 on a pre-tax basis and \$18,110 on a post-tax basis.³

The pre-tax annualized cost is used in calculating the cost of the regulation. It incorporates the cost to industry for the purchase, installation, and operation of additional pollution control equipment as well as the cost to federal and state government from lost tax revenues. (Every tax dollar that a business does not pay due to a tax shield is a tax dollar lost to the government.) Post-tax annualized costs are used to shock the market model because they reflect the cost to industry.

A.4 REFERENCES

- CCH. 1999a. Commerce Clearing House, Inc. 2000 State Tax Handbook. Chicago, IL.
- CCH. 1999b. Commerce Clearing House, Inc. 2000 U.S. Master Tax Guide. Chicago, IL.
- U.S. Department of Commerce, Bureau of Economic Analysis. 2000. *Gross Domestic Product by Industry for 1997-1999*. Survey of Current Business. Washington, D.C. December.
- OMB. 1992. Guidelines and Discount Rates for Benefit-cost Analysis of Federal Programs. Appendix A. Revised Circular No. A-94. October 29. Washington, DC: Office of Management and Budget.
- RIA. 1999. The Research Institute of America, Inc. The Complete Internal Revenue Code. New York, NY. July 1999 Edition.
- U.S. EPA. 2002. *Development Document for the Proposed Revisions to the Effluent Limitations Guidelines for the Meat Products Industry*. EPA-821-B-01-007. Washington, DC: U.S. Environmental Protection Agency, Office of Water.

³ Note that post-tax annualized cost can be calculated in two ways. The first way is to calculate the annualized cost as the difference between the annuity value of the cash flows (Column 7) and the adjusted tax shield (Column 8). The second way is to calculate the annuity value of the cash flows after tax shields (Column 9). Both methods yield the same result.

APPENDIX B

FACILITY-LEVEL ANALYSIS

EPA used publicly available information to project facility-level impacts under the proposed rule. EPA based its facility-level analysis on the U.S. Census Bureau's 1997 *Economic Census* of the following four industries: Animal (Except Poultry) Slaughtering (NAICS 311611), Meat Processed From Carcasses (NAICS 311612), Rendering and Meat Byproduct Processing (NAICS 311613), and Poultry Processing (NAICS 311615). The Census provides detailed revenue and cost information by employment class, which EPA used to build model facilities. To analyze facility-level impacts based on the *Economic Census* data, EPA compared estimated compliance costs with four measures of income:

- Average establishment revenues
- Average establishment earnings before interest and taxes (EBIT)
- Average establishment net income
- Average establishment cash flow

Each level of analysis more closely approaches the goal of using estimated compliance costs to draw strong inferences about definable impacts on the establishment, but each level of analysis requires additional assumptions to generate the test data. Thus, each level of analysis presents a tradeoff. For example, the relationship between facility net income and the impact of compliance costs is much more clearly defined than the relationship between facility revenues and compliance cost impacts. Estimating average facility net income requires more assumptions than estimating average facility revenues, however, and that increases the uncertainty about the baseline benchmark against which impacts are measured.

Section B.1 presents an intuitive overview of the strategy EPA used to develop model facilities and measures of their income. Average facility values and the variance of those values are discussed in sections B.2.1 through B.2.4 below — one section for each of the four proposed levels of analysis. Section B.3 describes issues concerning subcategorizing the proposed model facilities and matching those facilities with the engineering model facilities. Section B.4 examines a question concerning the

probability that some facilities may be projected to have negative income in the baseline. Section B.5 outlines some qualifications and limitations of the methodology used to model meat product facilities.

B.1 GENERAL MODELING STRATEGY

For each level of analysis, EPA's strategy was similar. First, average revenues, net income, or cash flow was estimated for model establishments of different sizes. EPA based its size classification for developing model establishments on facility employment, taking advantage of the detailed information the Census Bureau provides by employment class. Table B-1 presents the number of establishments by employment class within each industry. The number of employment classes within each industry is large, providing a good level of detail, and the number of observations within each employment class is generally large. Thus, the average facility income measures should not be skewed by a small number of atypical observations.

Using average income alone as the basis for projecting economic impacts on model establishments imposes a limitation on the analysis. Simple comparison of average compliance costs with the model facility's average income generates an all-or-nothing result: all facilities represented by a particular model incur impacts identical to those of the model facility. For example, if the model facility is projected to close because it incurs compliance costs exceeding cash flow, then all facilities represented by that model are projected to close. In reality, however, incomes of the actual facilities that the model represents compose a distribution around the mean income (i.e., the model facility's income) for that group of facilities. Actual facilities that are smaller than the average, therefore, may be negatively impacted by the proposed rule even if the model facility appears unaffected. Conversely, larger-than-average facilities may be unaffected by the rule even if the model facility is affected.

To deal with this limitation, EPA estimated the distribution of facility income around the model facility mean. In order to do this, EPA obtained from the Census Bureau a special tabulation of the variances and covariances of important income components around their respective mean within each employment class (U.S. Census Bureau. 2001). Combining this information with the assumption that these observations are normally distributed around the mean, EPA constructed a distribution of revenues, EBIT, net income, and cash flow for the group of facilities represented by each model. Given

Table B-1
Number of Establishments by Industry and Employment Class, 1997

Establishment Size by Number of Employees	Number of Establishments in NAICS Industry:			
	311611: Animal Slaughter	311612: ^a Meat Processed From Carcasses	311613: ^b Rendering	311615: Poultry Processing
1 to 4	507	293	27	54
5 to 9	275	176	30	18
10 to 19	225	206	40	15
20 to 49	141	246	81	35
50 to 99	79	140	62	34
100 to 249	64	143	0	67
250 to 499	33	68	0	79
500 to 999	21	25	0	97
1,000 to 2,499	39	0	0	70
2,500 or Greater	9	0	0	5
Total	1,393	1,297	240	474

Source: U.S. Census Bureau, 1997a through 1997d.

^a Due to disclosure issues, the 500-to-999-employee establishment size for NAICS 311612 (Meat Processed From Carcasses) includes data for 2 facilities with employment between 1,000 and 2,499 and 1 facility with employment greater than 2,500.

^b Due to disclosure issues, the 50-to-99-employee establishment size for NAICS 311613 (Rendering) includes data for 10 facilities with employment between 100 and 249 and 1 facility with employment between 250 and 499.

the large number of observations within each employment class (see Table B-1), the assumption of a normal distribution around each mean should be acceptable.

Having generated a distribution around the model facility mean, EPA compared estimated compliance costs with an appropriate benchmark for each model in order to project the number and percentage of facilities estimated to close under the effluent guideline. Suppose, for example, that a model facility has an average cash flow of \$100,000. That model facility represents an entire class of facilities, some of which will earn cash flow less than \$100,000. If compliance costs are estimated to be \$40,000 for the model facility, then the model facility itself would not be projected to close, but other facilities in the same class with cash flow of \$40,000 or less would be expected to close. Given the mean and variance of cash flow for that model class, the probability that facilities in that class earning less than \$30,000 in cash flow can be readily calculated. Multiplying that probability by the number of facilities in the class results in the projected number of closures for that class. Multiplying the projected number of closures by the average number of employees per facility in the employment class results in an estimate of employment impacts.

This methodology is illustrated in Figure B-1. The curve represents the cumulative distribution function for cash flow around the model facility average of \$100,000. For the purpose of this illustration, EPA set the standard deviation of the distribution equal to 100,000, and EPA assumed cash flow is normally distributed.¹ The vertical line marking the estimated average annualized compliance costs of \$40,000 determines the probability of closure. Reading from the point on the graph where the distribution function intersects the compliance cost marker, the probability that a facility earns cash flow that is less than \$40,000 per year is about 28 percent. Note, however, that the distribution function also shows that about 16 percent of facilities in this class already have cash flow less than zero before the regulation is promulgated (the point where the distribution crosses the \$0 value). Therefore, the *incremental* probability that a facility in this model class will close due to the regulation is about 12

¹ The standard deviation of a distribution is equal to the square root of the variance of the distribution. Thus, standard deviation and variance are equivalent ways of measuring the dispersion of a distribution around its mean value. A larger variance for a given mean value reflects a more dispersed distribution; the curve in Figure B-1 would be flatter.

Figure B-1
Baseline Distribution Function for
Model Establishment Cash Flow

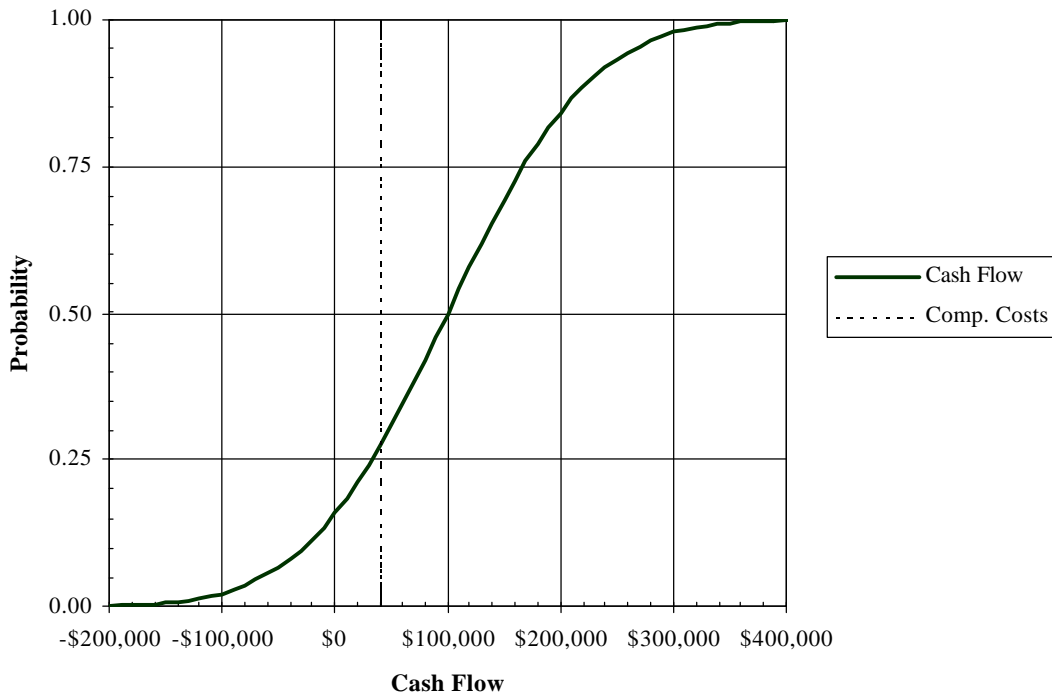

percent (28 percent minus 16 percent).² Multiplying this incremental probability of closure by the number of establishments in the model class results in EPA's projected number of closures due to the proposed rule.

To employ this modeling strategy, EPA must develop measures of several parameters used to create the models. First, EPA must develop estimates of average model facility income in each class to be examined. Second, it must estimate the variance — or dispersion — of income for each class. EPA used a variety of publicly available data sources to develop its estimates of these parameters. Third, EPA must estimate how income is distributed (i.e., the shape of the cumulative distribution function) in each class. As described above, EPA assumes that facility income is normally distributed in each class. Finally, EPA must match its model facilities developed from economic and financial data to the model facilities used to estimate compliance costs based on engineering data. Each of these components in EPA's modeling strategy is examined in detail in the sections to follow of this Appendix.³

B.2 FACILITY INCOME

B.2.1 Facility Revenues

The Census Bureau publishes the value of total shipments by employment size for each NAICS code, along with the number of facilities in that size class. The value of total shipments includes the value of primary and secondary shipments as well as resale, contract, and other miscellaneous receipts. This makes the value of total shipments a reasonable proxy for total revenues. EPA calculated average facility revenues by employment class within each industry as the value of total shipments divided by the number of establishments in each class. EPA obtained from the Census Bureau the variance of the value

² EPA cannot evaluate the effect of the regulation on facilities with negative cash flow in the baseline ("baseline closures"). As discussed in Section 3.1.2, the basis for EPA's closure analysis is that an establishment must have positive earnings prior to the regulation, and negative earnings after regulation. If an establishment has negative earnings prior to the regulation, then it may very well close even if the regulation is never promulgated. Thus, closure of such an establishment should not be considered an impact of the regulation.

³ EPA explored the implications of using different data sources to estimate the variance of income distribution, as well as alternative assumptions concerning the distribution of income within each class. The sensitivity analyses are presented in Appendix E.

of shipments around the mean within each employment class. Table B-2 presents the mean and standard deviation of revenues for each employment class in the affected NAICS codes.

B.2.2 Facility EBIT

B.2.2.1 Average Facility EBIT by Employment Class

Next, EPA estimated average model facility EBIT in each class. EBIT is calculated by subtracting cost of goods sold, general, sales, and administrative costs (GS&A), and depreciation and amortization from total revenues. EBIT then becomes the basis for calculating model facility net income and cash flow.

As with revenues, EPA compared estimated compliance costs and the distribution of EBIT by employment class to project the number and percentage of facilities expected to incur costs exceeding specified percentages of EBIT. There are no clearly defined thresholds for measuring impacts relative to EBIT, as there are for income measures like cash flow. Although clearly a facility would be projected to close if its pretax annualized compliance costs exceeded its EBIT, a facility would also be projected to close if its compliance costs were some fraction of EBIT (i.e., if the facility also had to pay taxes and make interest payments on loans out of EBIT to remain open). Nonetheless, using EBIT as a benchmark against which to compare compliance costs is an improvement over using revenues alone as an income measure, since the latter make no allowance for facility operating costs.

EPA used *1997 Economic Census* data to estimate model facility EBIT and its variance by employment class within each NAICS industry (U.S. Census Bureau, 1999a - 1999d). Facility revenues were estimated by value of shipments. The Census Bureau provides most of the significant categories of operating costs that would be included in EBIT. For each of the four meat product NAICS industries, the Bureau provides:

- Payroll and material costs directly attributed to the employment class level
- Benefits, depreciation, rent, and purchased services attributed at the industry level

Table B-2
Model Facility Income Mean and Standard Deviation by Employment Class

NAICS Establishment Employment Size Class	Income Measure (x \$1,000)			Standard Deviation (x 1,000)		
	Revenues	Net Income	Cash Flow	Revenues	Net Income	Cash Flow
NAICS 311611: Animal (Except Poultry) Slaughtering						
1 to 4	\$440	\$28	\$33	292	56	56
5 to 9	\$1,265	\$46	\$55	842	89	89
10 to 19	\$2,655	\$64	\$86	1766	147	147
20 to 49	\$8,413	\$336	\$382	5598	617	617
50 to 99	\$22,490	\$1,303	\$1,438	14964	2260	2260
100 to 249	\$69,474	\$2,696	\$3,248	46227	5211	5211
250 to 499	\$160,914	\$4,005	\$4,714	107069	8024	8024
500 to 999	\$262,734	\$4,983	\$6,924	174819	10403	10403
1,000 to 2,499	\$677,948	\$29,321	\$33,489	451095	53662	53662
≥ 2,500	\$1,426,054	\$9,934	\$18,501	948872	31988	31988
NAICS 311612: Meat Processed From Carcasses						
1 to 4	\$413	\$30	\$40	381	81	81
5 to 9	\$1,393	\$152	\$181	1286	320	320
10 to 19	\$2,845	\$160	\$204	2626	367	367
20 to 49	\$7,452	\$462	\$562	6877	1079	1079
50 to 99	\$19,049	\$1,823	\$2,045	17581	3819	3819
100 to 249	\$52,075	\$4,510	\$5,450	48062	9936	9936
250 to 499	\$105,066	\$6,308	\$7,555	96969	13266	13266
500 to 999 ¹	\$172,089	\$14,364	\$16,840	158827	31591	31591
1,000 to 2,499	NA	NA	NA	NA	NA	NA
≥ 2,500	NA	NA	NA	NA	NA	NA
NAICS 311613: Rendering						
1 to 4	\$860	\$14	\$40	1155	311	311
5 to 9	\$3,818	\$510	\$572	5128	794	794
10 to 19	\$6,476	\$608	\$730	8697	1047	1047
20 to 49	\$11,681	\$1,879	\$2,244	15688	3199	3199
50 to 99 ²	\$17,108	\$2,406	\$3,069	22976	4476	4476
100 to 249	NA	NA	NA	NA	NA	NA
250 to 499	NA	NA	NA	NA	NA	NA
500 to 999	NA	NA	NA	NA	NA	NA
1,000 to 2,499	NA	NA	NA	NA	NA	NA
≥ 2,500	NA	NA	NA	NA	NA	NA

Table B-2 (cont.)
Model Facility Income Mean and Standard Deviation by Employment Class

NAICS Establishment Employment Size Class	Income Measure (x \$1,000)			Standard Deviation (x 1,000)		
	Revenues	Net Income	Cash Flow	Revenues	Net Income	Cash Flow
NAICS 311615: Poultry Processing						
1 to 4	\$258	\$7	\$18	158	28	28
5 to 9	\$759	\$23	\$40	465	70	70
10 to 19	\$3,292	\$453	\$484	2017	631	631
20 to 49	\$11,721	\$2,428	\$2,564	7184	3266	3266
50 to 99	\$14,881	\$1,463	\$1,618	9120	2225	2225
100 to 249	\$29,999	\$2,324	\$2,745	18386	3966	3966
250 to 499	\$71,300	\$3,466	\$4,602	43698	5956	5956
500 to 999	\$117,768	\$13,362	\$14,784	72177	20658	20658
1,000 to 2,499	\$182,579	\$17,045	\$20,179	111898	29094	29094
≥ 2,500	\$321,884	\$1,072	\$7,856	197275	4551	4551

¹ Due to disclosure issues, data for 2 facilities with 1,000 < employment < 2,499, and 1 facility with 2,500 employment combined in lower category for NAICS 311612.

² Due to disclosure issues, data for 10 facilities with 100 < employment < 249, and 1 facility with 250 < employment < 499 combined in lower category for NAICS 311613.

In addition to payroll and material costs, the Bureau provides capital expenditures and value added directly attributed to the employment class level.

EPA used a additional assumptions to distribute industry-level costs to the employment class level:

- Employment benefits were assumed to be proportionate to payroll.
- Depreciation was assumed to be proportionate to capital expenditures.
- Rent payments were assumed to be proportionate to capital expenditures.
- Building repairs were assumed to be proportionate to capital expenditures.
- Equipment repairs were assumed to be proportionate to capital expenditures.
- Communications were assumed to be proportionate to the value of shipments.
- Legal services were assumed to be proportionate to the value of shipments.
- Accounting services were assumed to be proportionate to the value of shipments.
- Data processing services were assumed to be proportionate to the value of shipments.
- Advertising services were assumed to be proportionate to value added.
- Refuse removal was assumed to be proportionate to material costs

Using capital expenditures to distribute depreciation, rent, and repair costs to the employment class level is based on the implicit assumption that capital expenditures are proportionate to capital stocks. For example, expenditures on building repairs are presumably a function of buildings owned; because that information is not available, EPA used an additional assumption that in general, capital stocks by employment class are proportionate to capital expenditures by employment class.

EPA thus calculated model facility EBIT as the average value of shipments (payroll, material costs, benefits, depreciation, rent, and all specified purchased services) within each employment class. Because revenues, payroll, and cost of materials are the most significant components of EBIT, the error introduced by distributing industry-level data among employment classes should be small. Table B-3 presents Census data used to estimate EBIT at the employment class level. For NAICS 311613

Table B-3
Components of 1997 Earnings Before Interest and Taxes Data by Industry

Component	NAICS 311611		NAICS 311612		NAICS 311613		NAICS 311615	
	Dollars (Millions)	Percent of Costs	Dollars (Millions)	Percent of Costs	Dollars (Millions)	Percent of Costs	Dollars (Millions)	Percent of Costs
1997 Census of Manufactures Revenue Data Distributed by Employment Class								
Total Value of Shipments ^a	\$54,501.6	NA	\$25,005.5	NA	\$2,571.9	NA	\$31,656.1	NA
1997 Census of Manufactures Cost Data Distributed by Employment Class								
Total Payroll ^a	\$3,245.8	6.4%	\$2,324.5	11.7%	\$269.2	14.6%	\$4,036.5	15.6%
Total Cost of Materials ^a	\$45,996.3	90.1%	\$15,846.5	80.0%	\$1,325.2	71.9%	\$19,678.2	76.0%
1997 Census of Manufactures Cost Data Distributed by 6 Digit NAICS Industry								
Total Benefits	\$710.5	1.4%	\$605.8	3.1%	\$72.1	3.9%	\$997.4	3.9%
Depreciation	\$340.0	0.7%	\$343.3	1.7%	\$95.5	5.2%	\$483.6	1.9%
Rental Payments	\$477.8	0.9%	\$124.8	0.6%	\$21.2	1.1%	\$139.9	0.5%
Purchased Services	\$289.2	0.6%	\$553.1	2.8%	\$59.0	3.2%	\$542.9	2.1%
Repair	\$188.3	0.4%	\$190.5	1.0%	\$47.7	2.6%	\$381.4	1.5%
Communication	\$13.1	0.0%	\$160.5	0.8%	\$2.3	0.1%	\$57.3	0.2%
Legal	\$14.0	0.0%	\$8.1	0.0%	\$1.2	0.1%	\$9.1	0.0%
Accounting	\$10.3	0.0%	\$11.1	0.1%	\$0.6	0.0%	\$6.1	0.0%
Advertising	\$38.3	0.1%	\$89.4	0.5%	\$3.6	0.2%	\$57.0	0.2%
Computer	\$6.6	0.0%	\$5.9	0.0%	\$0.4	0.0%	\$5.5	0.0%
Refuse Removal	\$18.7	0.0%	\$87.5	0.4%	\$3.1	0.2%	\$26.5	0.1%
Estimated Costs ^b	\$51,059.6	100.0%	\$19,797.9	100.0%	\$1,842.1	100.0%	\$25,878.6	100.0%

Source: U.S. Census Bureau, 1997a through 1997d.

^a Totals presented in this table are from published Census data; average values per establishment used in calculations are based on revised data provided by Census in a special tabulation.

^b Calculated from Census data as the sum of payroll, materials, benefits, depreciation, rental, and purchased service costs.

(rendering), payroll and material costs make up over 86 percent of estimated costs (where estimated costs equal the sum of payroll, material costs, benefits, depreciation, rent, and purchased services). For NAICS 311611 (slaughter), 311612 (processing), and 311615 (poultry), payroll and material costs exceed 90 percent of estimated costs.

Table B-4 presents a sample calculation of average establishment EBIT by employment class within each industry using these assumptions. With few exceptions, EBIT increases monotonically with establishment size. For animal slaughtering establishments (NAICS 311611) and poultry processors (NAICS 311615), EBIT for the largest employment class is smaller than EBIT for many other classes. This might indicate that some of these very large establishments are cost centers for larger business establishments.

B.2.2.2 Variance of EBIT by Employment Class

Although the variance of revenues (value of shipments) is directly provided by the Census special tabulation, the variance of EBIT needs to be estimated. EBIT is a linear function of its revenue and cost components. Thus, the variance of EBIT can be estimated using the standard statistical relationship where the variance of a linear function is itself a linear function of the variance and covariance of its constituents.

To estimate the distribution of EBIT for each model facility, EPA used the variance and covariance of the value of shipments (R), payroll (P) and material costs (M) for each employment class provided by Census. Given that mean EBIT, \bar{x}_E , for an employment class is:

$$\bar{x}_E = \bar{x}_R - \bar{x}_P - \bar{x}_M$$

where \bar{x}_i denotes the mean value of revenues, R, payroll, P, and material costs, M. EPA computed the variance of EBIT, σ_E^2 , as:

$$\sigma_E^2 = \sigma_R^2 + \sigma_P^2 + \sigma_M^2 - 2\sigma_{RM} - 2\sigma_{RP} + 2\sigma_{PM}$$

Table B-4
Average Estimated Components of 1997 EBIT by Employment Class

Establishment Size by Number of Employees	Number of Establishments	Components of EBIT per Establishment					
		Revenues ^c (\$ thousands)	Employment Costs ^d (\$ thousands)	Material Costs ^e (\$ thousands)	Purchased Services ^f (\$ thousands)	Depreciation ^g (\$ thousands)	EBIT (\$ thousands)
NAICS 311611: Animal (Except Poultry) Slaughtering							
1 to 4	507	\$408.3	\$37.7	\$318.9	\$9.7	\$4.5	\$37.6
5 to 9	275	\$1,175.2	\$111.0	\$939.8	\$18.5	\$8.2	\$97.6
10 to 19	225	\$2,465.9	\$281.4	\$1,969.9	\$44.3	\$20.0	\$150.3
20 to 49	141	\$7,814.5	\$799.2	\$6,173.2	\$100.0	\$42.8	\$699.3
50 to 99	79	\$20,890.8	\$1,992.1	\$16,159.2	\$289.2	\$125.0	\$2,325.3
100 to 249	64	\$64,534.8	\$4,458.4	\$53,391.3	\$1,129.5	\$512.8	\$5,042.8
250 to 499	33	\$149,473.0	\$9,254.7	\$130,659.0	\$1,609.5	\$658.3	\$7,291.5
500 to 999	21	\$244,054.0	\$20,216.7	\$202,413.0	\$3,996.5	\$1,803.4	\$15,624.4
1,000 to 2,499	39	\$629,747.0	\$46,913.2	\$518,008.0	\$8,844.5	\$3,871.4	\$52,109.9
2,500 or Greater	9	\$1,324,664.0	\$81,251.8	\$1,191,097.0	\$17,308.1	\$7,958.6	\$27,048.4
NAICS 311612: Meat Processed From Carcasses							
1 to 4	293	\$383.3	\$51.8	\$261.5	\$14.9	\$9.9	\$45.2
5 to 9	176	\$1,294.4	\$167.3	\$755.0	\$47.6	\$27.2	\$297.3
10 to 19	206	\$2,642.5	\$409.7	\$1,693.0	\$78.5	\$41.0	\$420.3
20 to 49	246	\$6,921.8	\$1,013.9	\$4,660.3	\$191.2	\$93.0	\$963.4
50 to 99	140	\$17,694.5	\$2,384.4	\$11,392.4	\$467.4	\$205.4	\$3,244.9
100 to 249	143	\$48,372.6	\$5,563.8	\$32,007.8	\$1,574.0	\$872.6	\$8,354.4
250 to 499	68	\$97,595.6	\$11,591.7	\$65,486.4	\$2,573.0	\$1,157.9	\$16,786.6
500 to 999 ^a	25	\$159,854.0	\$20,177.4	\$106,698.0	\$4,647.7	\$2,300.5	\$26,030.4

Table B-4 (continued)
Average Estimated Components of 1997 EBIT by Employment Class

Establishment Size by Number of Employees	Number of Establishments	Components of EBIT per Establishment					
		Revenues ^c (\$ thousands)	Employment Costs ^d (\$ thousands)	Material Costs ^e (\$ thousands)	Purchased Services ^f (\$ thousands)	Depreciation ^g (\$ thousands)	EBIT (\$ thousands)
NAICS 311613: Rendering							
1 to 4	27	\$798.8	\$80.3	\$645.5	\$22.1	\$24.0	\$27.0
5 to 9	30	\$3,546.5	\$237.8	\$2,240.0	\$58.6	\$57.5	\$952.6
10 to 19	40	\$6,015.4	\$538.8	\$4,105.3	\$110.8	\$113.4	\$1,147.1
20 to 49	81	\$10,850.3	\$1,378.1	\$5,539.5	\$296.6	\$338.9	\$3,297.2
50 to 99 ^b	62	\$15,891.5	\$2,753.3	\$7,684.8	\$516.0	\$615.6	\$4,321.7
NAICS 311615: Poultry Processing							
1 to 4	54	\$239.6	\$42.4	\$160.4	\$13.5	\$10.8	\$12.6
5 to 9	18	\$705.4	\$132.3	\$496.1	\$20.2	\$15.6	\$41.2
10 to 19	15	\$3,057.5	\$304.2	\$1,820.4	\$47.3	\$29.3	\$856.4
20 to 49	35	\$10,888.1	\$807.3	\$5,700.2	\$195.8	\$126.2	\$4,058.6
50 to 99	34	\$13,822.7	\$1,592.7	\$9,291.6	\$223.4	\$144.7	\$2,570.2
100 to 249	67	\$27,866.4	\$4,145.4	\$18,567.2	\$558.3	\$391.0	\$4,204.5
250 to 499	79	\$66,230.9	\$9,074.6	\$44,573.7	\$1,473.5	\$1,055.5	\$10,053.7
500 to 999	97	\$109,395.0	\$16,393.6	\$66,878.5	\$1,979.3	\$1,320.9	\$22,822.8
1,000 to 2,499	70	\$169,598.0	\$30,106.8	\$102,010.0	\$3,999.1	\$2,911.2	\$30,570.8
2,500 or Greater	5	\$298,999.0	\$58,473.6	\$215,803.0	\$8,164.4	\$6,301.3	\$10,256.7

^a Includes data for 1 facility with employment greater than 2,500 and 2 facilities with employment between 1,000 and 2,499, due to disclosure issues.

^b Includes data for 1 facility with employment between 250 and 499 and 10 facilities with employment between 100 and 249, due to disclosure issues.

^c Census value of shipments by employment class (including value of secondary shipments and miscellaneous receipts).

^d Sum of Census payroll by employment class and Census industry benefits attributed to employment class by EPA using percentage of payroll.

^e Census material costs by employment class.

^f Sum of all other Census industry costs attributed to employment class by EPA using the following factors: rent and repairs—percentage of capital expenditure (assumed proportionate to capital stocks); advertising—percentage of value added; refuse removal—percentage of material costs; communication, legal, accounting, and computer services—percentage of total shipments.

^g Census industry depreciation attributed to employment class by EPA using percentage of capital expenditure (assumed proportionate to capital stocks).

where σ_i^2 and σ_{ij} represent the variance and covariance of revenues, payroll, and material costs respectively (Mendenhall et al., 1990). Although payroll and material cost do not comprise all operating expenses included in EBIT, they do comprise the vast majority of EBIT. Hence, excluding the variance for the remaining components should not cause a significant error in the variance estimate.

B.2.3 Facility Net Income

B.2.3.1 Average Facility Net Income by Employment Class

EPA calculated net income for each employment class model facility in each industry from EBIT, using additional assumptions to estimate tax and interest payments. Data for these two additional components of net income were derived from two Census Bureau publications, *Annual Survey of Manufactures* (ASM) and *Economic Census*, along with the Internal Revenue Service code. Because one must use an additional layer of assumptions to estimate net income from EBIT, the uncertainty associated with the net income estimate is greater than that for EBIT.

Estimating tax payments is relatively straightforward. EPA assumed that establishment EBIT is equal to business entity EBIT as the basis for calculating taxes. To estimate facility tax payments, EPA multiplied the model facility's EBIT by the sum of the relevant federal corporate income tax rate and the average state corporate income tax. To estimate net income, EPA subtracted the estimated tax payment from EBIT for each model facility.

EPA estimated interest payments using a combination of ASM data on past investment by industry, Census data on relative investment in buildings and equipment, and assumptions about investment behavior. EPA first scaled ASM time series data on industry investment, which is based on Standard Industrial Classification (SIC) codes, to represent the current NAICS meat product industries. EPA then used the average percentages of meat product industry investment in equipment and structures, as presented in the *Economic Census*, to divide the ASM investment time series into those two components.

In estimating interest payments from the time series of past investment in equipment and structures, EPA made a series of assumptions concerning industry borrowing behavior. EPA assumed that:

- All investment in each year was funded through bank loans.
- The interest rate on those loans was equal to the nominal prime rate for that year plus 1 percent. (Since ASM investment time series data is in nominal terms, a nominal interest rate is appropriate.)
- The average loan period was 7 years for equipment and 25 years for structures.

Using these assumptions, EPA developed a time series estimate of loan payments made by the industry, and the portion of each year's loan payments accounted for by interest (e.g., using the Lotus @IPAYMT function). Total interest payments in the baseline year equals the sum of this year's interest payments on the stream of past years' investment.⁴ Interest payments were then attributed to each employment class based on the percentage of industry investment accounted for by that employment class in the 1997 Census. Table B-5 presents a sample calculation of establishment net income by industry and employment class using the methods described above for attributing tax and interest payments to employment classes.

B.2.3.2 Distribution of Net Income Within Employment Class

EPA also estimated the variance of net income for each model facility from its estimated variance for EBIT. If the mean of a distribution is multiplied by some scalar a , then the variance of that distribution will change by the square of a . That is, if the mean net income for a model facility is some percentage of facility EBIT ($\bar{x}_{NI} = a\bar{x}_E$), then the variance of facility net income is equal to the square of that percentage multiplied by the variance of EBIT ($\sigma^2_{NI} = a^2\sigma^2_E$). EPA used the ratio of facility net income to EBIT to determine the scalar for estimating the variance of net income (adjustments to variance are discussed in more detail in Section B.4.3). The estimated mean and variance for net income in each employment class by NAICS code is presented in Table B-2.

⁴ For example, interest payments on equipment investment for the year 1997 would equal the sum of interest paid in year 25 of loans from 1973 plus the interest paid in year 24 of loans from 1974, and so on.

Table B-5
Example of Average Estimated 1997 Net Income and Cash Flow by Employment Class

Establishment Size by Number of Employees	Number of Establishments	Estimated EBIT, Net Income, and Cash Flow per Establishment				
		EBIT (\$ thousands)	Taxes ^c (\$ thousands)	Interest ^d (\$ thousands)	Net Income (\$ thousands)	Cash Flow (\$ thousands)
NAICS 311611: Animal (Except Poultry) Slaughtering						
1 to 4	507	\$37.6	\$8.1	\$3.7	\$25.7	\$30.2
5 to 9	275	\$97.6	\$47.8	\$6.8	\$43.0	\$51.3
10 to 19	225	\$150.3	\$74.2	\$16.5	\$59.5	\$79.6
20 to 49	141	\$699.3	\$351.6	\$35.3	\$312.4	\$355.2
50 to 99	79	\$2,325.3	\$1,011.7	\$103.2	\$1,210.4	\$1,335.4
100 to 249	64	\$5,042.8	\$2,115.0	\$423.3	\$2,504.5	\$3,017.3
250 to 499	33	\$7,291.5	\$3,028.0	\$543.4	\$3,720.1	\$4,378.4
500 to 999	21	\$15,624.4	\$9,507.4	\$1,488.5	\$4,628.5	\$6,431.9
1,000 to 2,499	39	\$52,109.9	\$21,677.7	\$3,195.5	\$27,236.7	\$31,108.1
2,500 or Greater	9	\$27,048.4	\$11,252.2	\$6,569.0	\$9,227.3	\$17,185.8
NAICS 311612: Meat Processed From Carcasses						
1 to 4	293	\$45.2	\$9.8	\$8.0	\$27.4	\$37.3
5 to 9	176	\$297.3	\$133.9	\$22.0	\$141.4	\$168.6
10 to 19	206	\$420.3	\$238.3	\$33.1	\$148.9	\$189.9
20 to 49	246	\$963.4	\$458.8	\$75.1	\$429.4	\$522.4
50 to 99	140	\$3,244.9	\$1,385.1	\$166.0	\$1,693.8	\$1,899.2
100 to 249	143	\$8,354.4	\$3,459.6	\$705.3	\$4,189.6	\$5,062.2
250 to 499	68	\$16,786.6	\$9,990.8	\$935.9	\$5,859.9	\$7,017.8
500 to 999 ^a	25	\$26,030.4	\$10,828.6	\$1,859.4	\$13,342.3	\$15,642.9

Table B-5 (continued)
Example of Average Estimated 1997 Net Income and Cash Flow by Employment Class

Establishment Size by Number of Employees	Number of Establishments	Estimated EBIT, Net Income, and Cash Flow per Establishment				
		EBIT (\$ thousands)	Taxes ^c (\$ thousands)	Interest ^d (\$ thousands)	Net Income (\$ thousands)	Cash Flow (\$ thousands)
NAICS 311613: Rendering						
1 to 4	27	\$27.0	\$5.8	\$8.1	\$13.1	\$37.0
5 to 9	30	\$952.6	\$454.4	\$24.7	\$473.5	\$531.0
10 to 19	40	\$1,147.1	\$533.4	\$48.7	\$565.1	\$678.5
20 to 49	81	\$3,297.2	\$1,406.3	\$145.4	\$1,745.5	\$2,084.4
50 to 99 ^b	62	\$4,321.7	\$1,822.3	\$264.1	\$2,235.4	\$2,851.0
NAICS 311615: Poultry Processing						
1 to 4	54	\$12.6	\$2.7	\$3.8	\$6.1	\$16.8
5 to 9	18	\$41.2	\$8.9	\$10.8	\$21.5	\$37.1
10 to 19	15	\$856.4	\$415.4	\$20.3	\$420.7	\$450.0
20 to 49	35	\$4,058.6	\$1,715.4	\$87.6	\$2,255.5	\$2,381.7
50 to 99	34	\$2,570.2	\$1,111.2	\$100.4	\$1,358.6	\$1,503.3
100 to 249	67	\$4,204.5	\$1,774.7	\$271.4	\$2,158.5	\$2,549.5
250 to 499	79	\$10,053.7	\$6,101.4	\$732.5	\$3,219.8	\$4,275.3
500 to 999	97	\$22,822.8	\$9,494.3	\$916.7	\$12,411.8	\$13,732.7
1,000 to 2,499	70	\$30,570.8	\$12,717.5	\$2,020.3	\$15,833.0	\$18,744.3
2,500 or Greater	5	\$10,256.7	\$6,183.8	\$3,077.0	\$995.9	\$7,297.1

^a Includes data for 1 facility with employment above 2,500 and 2 with employment between 1,000 and 2,499, due to disclosure issues.

^b Includes data for 1 facility with employment between 250 and 499 and 10 facilities with employment between 100 and 249, due to disclosure issues.

^c EPA assumed that average establishment EBIT by employment class equals average firm EBIT by employment class; EPA applied the federal corporate income tax rate and the average state corporate income tax rate to establishment EBIT.

^d Calculated by scaling 4-digit ASM investment data to 6-digit NAICS industry data; building/equipment investment split based on 1997 Census data; all investment assumed financed by loans; interest rate assumed equal to "prime plus 1 percent"; loan periods assumed to be 15 years for equipment and 30 years for structures.

Note that the link between impacts measured by comparing net income with compliance costs is much stronger than the link between revenues and compliance costs, although not stronger than the link between cash flow and compliance costs. However, because the estimate of net income is dependent upon a series of assumptions, the uncertainty concerning the accuracy of the net income measure is greater than for revenues. Thus, this analytic approach represents a tradeoff between the accuracy of the income measure and the certainty of the impacts based on that measure.

B.2.4 Facility Cash Flow

Cash flow is calculated as net income plus depreciation. Depreciation was estimated for the calculation of model establishment EBIT as described in section B.2.2.1 above. Estimated model facility cash flow is presented in Table B-5 along with net income estimates.

The distribution for estimated cash flow has an identical variance to net income, but a larger mean because depreciation is added to the mean of net income. The probability that cash flow is less than zero tends to be about 3 percent to 5 percent smaller than the probability that net income is less than zero.

Cash flow is the preferred method in financial management to evaluate investments (FASB, 1996; Brealey and Meyers, 1996; Brigham and Gapenski, 1997). When post-compliance cash flow is negative, the facility can be reasonably projected to close. This is the basis of the closure model (see Section 3.1.2 for more detail). Once again, however, given the additional assumption required to estimate cash flow from net income, there is a tradeoff between the level of certainty regarding impacts and the precision of the income measure.

EPA uses cash flow to estimate the number of potential facility closures and related employment impacts from the effluent guidelines by comparing posttax annualized compliance costs and cash flow. Cash flow is also used to calculate the number of facilities with compliance costs greater than 3 percent, 5 percent, or 10 percent of revenues.

B.3 SUBCATEGORIZATION, DISCHARGE TYPE, AND FACILITY SIZE

B.3.1 Basis for Subcategorization

To develop the engineering models used for estimating compliance costs and pollutant load reductions, EPA classified meat products industry based on the type of meat produced at the facility:

- Red meat (primarily beef and pork)
- Poultry (primarily chicken and turkey)
- Mixed (both red meat and poultry)
- Rendering products or meat byproducts (either red meat or poultry)

and the type of processes performed at the facility:

- First processing (slaughter)
- Further processing
- Rendering (the process resulting in meat byproducts)

The meat type and process classes resulting from this classification consist of combinations of the processes for each meat type. For example, a poultry facility may perform any of the following six combinations of processes, each one of which will place it in a different subcategory: (1) first processing, (2) further processing, (3) first and further processing, (4) first processing and rendering, (5) further processing and rendering, or (6) first processing, further processing, and rendering. Facilities that only perform rendering are subcategorized as renderers; facilities that perform rendering in combination with the other two processes are subcategorized with the appropriate meat type (red meat or poultry). As an empirical matter, EPA found that all affected facilities that process both red meat and poultry (“mixed” facilities) were found to perform only further processing or further processing and rendering activities.

EPA also classified facilities by discharge type and facility size. Discharge type distinguishes those facilities that discharge process wastewater directly into U.S. surface waters (direct dischargers)

from those that discharge wastewater to treatment works (indirect dischargers). Under the Clean Water Act, EPA may apply different standards to direct and indirect dischargers (see Section 1.1). Size, as determined by facility production and wastewater flow, was used to cost the appropriate treatment capacity for the facility. For the purposes of costing, EPA divided facilities in each subcategory into small, medium, large, and very large. Detailed information on subcategorization can be found in the Development Document (EPA, 2002).

B.3.2 Matching Economic Model Facilities With Engineering Model Facilities

In order to perform the economic impact analysis, EPA matched its economic model facilities to the engineering model facilities used to estimate costs. This matching was performed on the basis of two characteristics: (1) the relationship between production process and NAICS industry and (2) the relationship between production and revenues.

The Census Bureau classifies the meat product industry into four groups. All red meat facilities that perform animal slaughter (first processing), whether alone or in combination with other processes, fall into NAICS 311611. All red meat facilities that perform further processing (with or without rendering), but no slaughtering activities, are classified as belonging to NAICS 311612. Facilities performing poultry slaughter, poultry further processing, or both (with or without rendering), are contained in NAICS 311615. Finally, facilities that perform rendering, but no other processing activities, are classified in NAICS 311613.

Thus, model economic facilities were matched to the model engineering facilities, based on production, as follows:

- Red meat facilities — whether beef or pork — that perform first processing alone or in combination with further processing and/or rendering were assigned an economic model facility from NAICS 311611.
- Red meat facilities — whether beef or pork — that perform further processing alone or in combination with rendering, but no first processing, were assigned an economic model facility from NAICS 311612.

- Poultry facilities — whether chicken or turkey — that perform either first processing or further processing, alone or in combination with other processes, were assigned an economic model facility from NAICS 311615.
- Facilities that perform rendering — whether red meat or poultry — but no other processes were assigned an economic model facility from NAICS 311613.
- Mixed facilities — both red meat and poultry — perform further processing only and were assigned an economic model facility from NAICS 311612.

All model engineering facilities were assigned an economic model from one NAICS code only.

The economic model facilities were developed from data classified by employment size, while engineering cost models were sized by production and flow (for details see Development Document, U.S. EPA, 2002). EPA classified engineering models into small, medium, large, or very large based on examination of production and flow characteristics of facilities contained in the screener survey database. EPA then determined the appropriate size for each engineering cost model facility, and assigned each facility to a size class within a meat type and process class. To match the economic model facilities with the engineering model facilities, EPA calculated the median production for all facilities in that class. EPA then combined median production data for the engineering model facilities with meat product indicator prices to estimate revenues for each engineering model facility. These estimated revenues were then compared with each economic model facility's average revenues, and the model facility with the closest match was selected to represent the economic characteristics of that engineering facility.

EPA used the baseline prices from the market model as the indicator prices for the meat products (for more detail on the market model see Section 3.1.4.2). The baseline prices are estimated for the four meat types: beef, pork, chicken, and turkey. The engineering model facilities are categorized on the basis of: red meat, poultry, and rendering. To account for this, EPA calculated revenues twice for each engineering model facility using the prices of two meat types. For example, EPA estimated revenues for red meat facilities first using the price of beef, then using the price of pork. Similarly, EPA calculated revenues for poultry using the price of chicken as well as the price of turkey. This resulted in a range of revenues for each model class to be compared with economic model facility revenues. For mixed meats, EPA used production for each of the four meat types as a percentage of total model class production as calculated from screener survey data. These percentages were multiplied by the price for each meat type

in order to calculate model facility revenues as a weighted average. There were a few instances where the range of revenues complicated the assignment of facilities. In such cases, EPA assigned the engineering model facility to the economic model facility whose revenues were closest to both measures of estimated revenues.

Table B-6 presents each subcategory and facility size for which engineering models were developed, as well as the economic model EPA assigned to each size for the purpose of projecting impacts. For example, based on its examination of the screener survey database, EPA estimated that median production for the 28 indirect discharging facilities that perform a combination of first and further processing of red meat was 196 million pounds. After examining these facilities' production and flow characteristics, EPA determined that they were medium-sized producers for the purposes of costing. The production data was multiplied by the price indicators and this resulted in a range of estimated revenues from \$197,000 to \$218,000. Based on this, EPA assigned these 28 facilities an economic model facility from the 500 to 999 employee class in NAICS 311611 which has model facility revenues of \$262,700, the closest match.

B.4 NEGATIVE BASELINE FACILITY INCOME

Estimating the means and variances for the distribution of each model facility's income results in some probability greater than zero that facilities in each employment class earn negative income. Table B-7 presents the model facility mean and standard deviation for each income measure by employment class and NAICS code, as well as the probability that income is less than zero (based on that mean and standard deviation, and assuming income is normally distributed). This section discusses the reasons why model facilities might have negative income, as well as those reasons' implications for the model.

B.4.1 Actual Establishment Income Is Less Than Zero

Two possible reasons for negative establishment baseline income are attributable to the actual establishment financial data (collected by the Census Bureau) on which the estimated distribution is based:

Table B-6
Engineering Model Subcategories and Assigned Economic Model Facilities

Engineering Model Facility Size	Number of Facilities	Median Production (1,000 lbs)	Model Facility						
			NAICS Code	Employment Class	Model Facility Income (x \$1,000)				Employment
					Revenues	EBIT	Net Income	Cash Flow	
Red Meat First Processing									
Small	282	510	311611	1-4	\$440	\$40	\$28	\$33	2
Medium	6	55,664	311611	100-249	\$69,474	\$5,429	\$2,696	\$3,248	154
Red Meat Further Processing									
Small	2,532	300	311612	1-4	\$413	\$49	\$30	\$40	2
Medium	170	120,000	311612	250-499	\$105,066	\$18,071	\$6,308	\$7,555	353
Large	5	5,328,699	311612	500-999	\$172,089	\$28,023	\$14,364	\$16,840	738
Very Large	5	9,691,125	311612	500-999	\$172,089	\$28,023	\$14,364	\$16,840	738
Red Meat First and Further Processing									
Small	674	664	311611	1-4	\$440	\$40	\$28	\$33	2
Medium	28	196,181	311611	500-999	\$262,734	\$16,820	\$4,983	\$6,924	727
Red Meat First Processing and Rendering									
Small	29	1,699	311611	5-9	\$1,265	\$105	\$46	\$55	7
Medium	24	545,969	311611	1000-2499	\$677,948	\$56,098	\$29,321	\$33,489	1,585
Large	10	809,499	311611	1000-2499	\$677,948	\$56,098	\$29,321	\$33,489	1,585
Very Large	17	1,302,214	311611	1000-2499	\$677,948	\$56,098	\$29,321	\$33,489	1,585
Red Meat Further Processing and Rendering									
Small	32	363	311612	1-4	\$413	\$49	\$30	\$40	2
Medium	11	193,562	311612	500-999	\$172,089	\$28,023	\$14,364	\$16,840	738
Red Meat First Processing, Further Processing, and Rendering									
Small	75	1,581	311611	5-9	\$1,265	\$105	\$46	\$55	7
Medium	29	826,269	311611	1000-2499	\$677,948	\$56,098	\$29,321	\$33,489	1,585
Large	12	2,851,666	311611	1000-2499	\$677,948	\$56,098	\$29,321	\$33,489	1,585

**Table B-6 (cont.)
Engineering Model Subcategories and Assigned Economic Model Facilities**

Engineering Model Facility Size	Number of Facilities	Median Production (1,000 lbs)	Model Facility						
			NAICS Code	Employment Class	Model Facility Income (x \$1,000)				Employment
					Revenues	EBIT	Net Income	Cash Flow	
Poultry First Processing									
Small	19	1,321	311615	5-9	\$759	\$44	\$23	\$40	6
Medium	49	94,836	311615	250-499	\$71,300	\$10,823	\$3,466	\$4,602	375
Large	73	226,297	311615	1000-2499	\$182,579	\$32,911	\$17,045	\$20,179	1,360
Very Large	19	334,946	311615	1000-2499	\$182,579	\$32,911	\$17,045	\$20,179	1,360
Poultry Further Processing									
Small	272	308	311615	1-4	\$258	\$14	\$7	\$18	2
Medium	143	38,770	311615	100-249	\$29,999	\$4,526	\$2,324	\$2,745	161
Large	5	143,798	311615	250-499	\$71,300	\$10,823	\$3,466	\$4,602	375
Very Large	20	282,000	311615	1000-2499	\$182,579	\$32,911	\$17,045	\$20,179	1,360
Poultry First and Further Processing									
Small	20	376	311615	1-4	\$258	\$14	\$7	\$18	2
Medium	17	113,444	311615	250-499	\$71,300	\$10,823	\$3,466	\$4,602	375
Large	6	226,319	311615	1000-2499	\$182,579	\$32,911	\$17,045	\$20,179	1,360
Very Large	22	441,721	311615	1000-2499	\$182,579	\$32,911	\$17,045	\$20,179	1,360
Poultry First Processing and Rendering									
Small	0	0	311615	1-4	\$258	\$14	\$7	\$18	2
Medium	9	72,253	311615	100-249	\$29,999	\$4,526	\$2,324	\$2,745	161
Large	10	321,510	311615	1000-2499	\$182,579	\$32,911	\$17,045	\$20,179	1,360
Very Large	3	558,220	311615	1000-2499	\$182,579	\$32,911	\$17,045	\$20,179	1,360
Poultry Further Processing and Rendering									
Small	4	5,100	311615	10-19	\$3,292	\$922	\$453	\$484	13
Medium	9	76,417	311615	250-499	\$71,300	\$10,823	\$3,466	\$4,602	375
Large	6	429,598	311615	1000-2499	\$182,579	\$32,911	\$17,045	\$20,179	1,360

**Table B-6 (cont.)
Engineering Model Subcategories and Assigned Economic Model Facilities**

Engineering Model Facility Size	Number of Facilities	Median Production (1,000 lbs)	Model Facility						
			NAICS Code	Employment Class	Model Facility Income (x \$1,000)				Employment
					Revenues	EBIT	Net Income	Cash Flow	
Poultry First Processing, Further Processing and Rendering									
Medium	5	161,000	311615	250-499	\$71,300	\$10,823	\$3,466	\$4,602	375
Large	10	402,733	311615	1000-2499	\$182,579	\$32,911	\$17,045	\$20,179	1,360
Very Large	3	790,920	311615	1000-2499	\$182,579	\$32,911	\$17,045	\$20,179	1,360
Mixed Further Processing									
Small	716	493	311612	1-4	\$413	\$49	\$30	\$40	2
Medium	102	48,000	311612	100-249	\$52,075	\$8,994	\$4,510	\$5,450	163
Mixed Further Processing and Rendering									
Small	4	3,001	311612	10-19	\$2,845	\$452	\$160	\$204	14
Rendering									
Small	23	Unknown	311613	1-4	\$860	\$29	\$14	\$40	2
Medium	33	27,000	311613	20-49	\$11,681	\$3,550	\$1,879	\$2,244	35
Large	27	157,177	311613	20-49	\$11,681	\$3,550	\$1,879	\$2,244	35
Very Large	36	398,805	311613	50-99	\$17,108	\$4,652	\$2,406	\$3,069	83

A higher employment class could not be used for the red meat further large and very large subcategories using median production to match facilities because due to disclosure issues, Census data for 2 facilities with 1,000 < employment < 2,499, and 1 facility with employment more than 2,500 are combined in a lower category of NAICS 311612.

A higher employment class could not be used for the rendering very large subcategory using median employment to match facilities because data for 10 facilities with 100 < employment < 249, and 1 facility with 250 < employment < 499 combined in lower category for NAICS 311613.

Table B-7
Model Facility 1999 Mean Income by Employment Class and Probability Income Less than Zero

NAICS Establishment Employment Size Class	Income Measure (x \$1,000)				Standard Deviation (\$1,000)				Probability Income less than Zero			
	Revenues	EBIT	Net Income	Cash Flow	Revenues	EBIT	Net Income	Cash Flow	Revenues	EBIT	Net Income	Cash Flow
NAICS 311611: Animal (Except Poultry) Slaughtering												
1 to 4	\$440	\$40	\$28	\$33	292	82	56	56	6.6%	31.1%	31.1%	28.1%
5 to 9	\$1,265	\$105	\$46	\$55	842	202	89	89	6.6%	30.2%	30.2%	26.8%
10 to 19	\$2,655	\$162	\$64	\$86	1,766	372	147	147	6.6%	33.2%	33.2%	28.0%
20 to 49	\$8,413	\$753	\$336	\$382	5,598	1,381	617	617	6.6%	29.3%	29.3%	26.8%
50 to 99	\$22,490	\$2,503	\$1,303	\$1,438	14,964	4,341	2,260	2,260	6.6%	28.2%	28.2%	26.2%
100 to 249	\$69,474	\$5,429	\$2,696	\$3,248	46,227	10,492	5,211	5,211	6.6%	30.2%	30.2%	26.7%
250 to 499	\$160,914	\$7,850	\$4,005	\$4,714	107,069	15,727	8,024	8,024	6.6%	30.9%	30.9%	27.8%
500 to 999	\$262,734	\$16,820	\$4,983	\$6,924	174,819	35,116	10,403	10,403	6.6%	31.6%	31.6%	25.3%
1,000 to 2,499	\$677,948	\$56,098	\$29,321	\$33,489	451,095	102,668	53,662	53,662	6.6%	29.2%	29.2%	26.6%
≥ 2,500	\$1,426,054	\$29,119	\$9,934	\$18,501	948,872	93,770	31,988	31,988	6.6%	37.8%	37.8%	28.2%
NAICS 311612: Meat Processed From Carcasses												
1 to 4	\$413	\$49	\$30	\$40	381	134	81	81	13.9%	35.8%	35.8%	31.1%
5 to 9	\$1,393	\$320	\$152	\$181	1,286	674	320	320	13.9%	31.7%	31.7%	28.6%
10 to 19	\$2,845	\$452	\$160	\$204	2,626	1,037	367	367	13.9%	33.1%	33.1%	28.9%
20 to 49	\$7,452	\$1,037	\$462	\$562	6,877	2,421	1,079	1,079	13.9%	33.4%	33.4%	30.1%
50 to 99	\$19,049	\$3,493	\$1,823	\$2,045	17,581	7,317	3,819	3,819	13.9%	31.7%	31.7%	29.6%
100 to 249	\$52,075	\$8,994	\$4,510	\$5,450	48,062	19,813	9,936	9,936	13.9%	32.5%	32.5%	29.2%
250 to 499	\$105,066	\$18,071	\$6,308	\$7,555	96,969	38,002	13,266	13,266	13.9%	31.7%	31.7%	28.5%
500 to 999 ¹	\$172,089	\$28,023	\$14,364	\$16,840	158,827	61,633	31,591	31,591	13.9%	32.5%	32.5%	29.7%
1,000 to 2,499	NA	NA	NA	NA	NA	NA	NA	NA	NA	NA	NA	NA
≥ 2,500	NA	NA	NA	NA	NA	NA	NA	NA	NA	NA	NA	NA

Table B-7 (continued)
Model Facility 1999 Mean Income by Employment Class and Probability Income Less than Zero

NAICS Establishment Employment Size Class	Income Measure (x \$1,000)				Standard Deviation (\$1,000)				Probability Income less than Zero			
	Revenues	EBIT	Net Income	Cash Flow	Revenues	EBIT	Net Income	Cash Flow	Revenues	EBIT	Net Income	Cash Flow
NAICS 311613: Rendering												
1 to 4	\$860	\$29	\$14	\$40	1,155	642	311	311	22.8%	48.2%	48.2%	44.9%
5 to 9	\$3,818	\$1,026	\$510	\$572	5,128	1,597	794	794	22.8%	26.0%	26.0%	23.6%
10 to 19	\$6,476	\$1,235	\$608	\$730	8,697	2,126	1,047	1,047	22.8%	28.1%	28.1%	24.3%
20 to 49	\$11,681	\$3,550	\$1,879	\$2,244	15,688	6,042	3,199	3,199	22.8%	27.8%	27.8%	24.1%
50 to 99 ²	\$17,108	\$4,652	\$2,406	\$3,069	22,976	8,654	4,476	4,476	22.8%	29.5%	29.5%	24.6%
100 to 249	NA	NA	NA	NA	NA	NA	NA	NA	NA	NA	NA	NA
250 to 499	NA	NA	NA	NA	NA	NA	NA	NA	NA	NA	NA	NA
500 to 999	NA	NA	NA	NA	NA	NA	NA	NA	NA	NA	NA	NA
1,000 to 2,499	NA	NA	NA	NA	NA	NA	NA	NA	NA	NA	NA	NA
≥ 2,500	NA	NA	NA	NA	NA	NA	NA	NA	NA	NA	NA	NA
NAICS 311615: Poultry Processing												
1 to 4	\$258	\$14	\$7	\$18	158	58	28	28	5.1%	40.8%	40.8%	26.1%
5 to 9	\$759	\$44	\$23	\$40	465	133	70	70	5.1%	37.0%	37.0%	28.3%
10 to 19	\$3,292	\$922	\$453	\$484	2,017	1,285	631	631	5.1%	23.7%	23.7%	22.1%
20 to 49	\$11,721	\$4,369	\$2,428	\$2,564	7,184	5,876	3,266	3,266	5.1%	22.9%	22.9%	21.6%
50 to 99	\$14,881	\$2,767	\$1,463	\$1,618	9,120	4,209	2,225	2,225	5.1%	25.5%	25.5%	23.3%
100 to 249	\$29,999	\$4,526	\$2,324	\$2,745	18,386	7,726	3,966	3,966	5.1%	27.9%	27.9%	24.4%
250 to 499	\$71,300	\$10,823	\$3,466	\$4,602	43,698	18,596	5,956	5,956	5.1%	28.0%	28.0%	22.0%
500 to 999	\$117,768	\$24,570	\$13,362	\$14,784	72,177	37,985	20,658	20,658	5.1%	25.9%	25.9%	23.7%
1,000 to 2,499	\$182,579	\$32,911	\$17,045	\$20,179	111,898	56,176	29,094	29,094	5.1%	27.9%	27.9%	24.4%
≥ 2,500	\$321,884	\$11,042	\$1,072	\$7,856	197,275	46,875	4,551	4,551	5.1%	40.7%	40.7%	4.2%

¹ Due to disclosure issues, data for 2 facilities with 1,000 < employment < 2,499, and 1 facility with 2,500 employment combined in lower category for NAICS 311612.

² Data for 10 facilities with 100 < employment < 249, and 1 facility with 250 < employment < 499 combined in lower category for NAICS 311613.

Data for combined size class calculated as (total minus sum of all other size classes).

- The parent company that owns the establishment does not assign costs and revenues that reflect the true financial health of the establishment. Two important examples are cost centers and captive sites, which exist primarily to serve other facilities under the same ownership.⁵
- The establishment is in financial trouble; that is, true costs exceed revenues.

To the extent that these types of establishments are contained in an employment class, the projection of negative baseline income is accurate. In either case, EPA would be unable, even with the use of facility-specific survey data, to evaluate impacts to these establishments *as a result of the rule*.

B.4.2 Skewed Distributions

Two additional possible reasons for projected negative baseline establishment income are attributable to the methodology used to estimate the distributions:

- EPA assumed that the distribution of income around the model facility mean is normally distributed when, in fact, it is positively skewed.
- EPA could not directly measure the variance of the income distributions, but instead had to estimate it from incomplete data.

In these two cases, EPA's methodology would project that more establishments have negative baseline income than would be expected in the industry.

The effects of a positively skewed income distribution can be most apparent when one considers the distribution of establishment revenues. For the reasons listed above, it is possible — even probable — that some establishments earn negative income, whether measured by net income, or cash flow. However, an establishment cannot earn negative *revenues*, though establishments can earn zero revenues; the distribution of establishment revenues for an employment class should show zero facilities

⁵ Captive sites may show revenues, but the revenues are set approximately equal to the costs of the operation. Cost centers have no revenues assigned to them.

earning negative revenues.⁶ If, however, some facilities earn atypically large revenues, then the distribution may be positively skewed (e.g., the probability of the mean cash flow of \$100,000 in Figure B-1 would be significantly higher than 0.5; more than half of facilities in the model class would earn less than the mean cash flow). In such a case, using a normal, symmetric distribution to approximate the skewed distribution would likely result in an overestimate of the percentage of establishments earning negative income. The Census Bureau has confirmed that in general, the distribution of facilities in an employment size class tends to be positively skewed (Quash, 2001). However, even if the distribution of a variable such as revenues, payroll, or material costs is positively skewed, the distribution of a function of those variables (e.g., revenues minus payroll and material costs) will not necessarily be skewed.⁷

B.4.3 Adjustments to Variance

EPA used the Census special tabulation to directly calculate the variance for [value of shipments - (payroll + material costs)] in each NAICS code and employment class. However, the actual measures of facility income used in the facility-level economic impact model are:

- $EBIT = \text{value of shipments} - (\text{payroll} + \text{material costs} + \text{benefits} + \text{all other costs})$
- $\text{Net income} = [\text{value of shipments} - (\text{payroll} + \text{material costs} + \text{benefits} + \text{all other costs})] \times (1 - \text{tax rate}) - \text{estimated interest payments}$
- $\text{Cash flow} = \text{net income} + \text{depreciation}$

Because the actual income measures differed from the approximate income measure on which variance was estimated, EPA needed to adjust the variance of [value of shipments - (payroll + material costs)] associated with each of the actual income measures used in the model.

⁶ Table B-7 presents the model facility mean and standard deviation for each income measure by employment class and NAICS code, as well as the probability that income is less than zero (based on that mean and standard deviation, and assuming income is normally distributed).

⁷ The results of sensitivity analyses based on the assumption that the distributions of revenues and cash flow are skewed may be found in Appendix E.

To adjust income variance, EPA used the following rules concerning the expected value of mean and variance:

$$E[kx] = kE[x]$$

$$V[kx] = k^2V[x]$$

$$E[a \pm kx] = a \pm kE[x]$$

$$V[a \pm kx] = k^2V[x]$$

where k and a are scalars, $E[x]$ is the expected value of the variable x (i.e., the mean), and $V[x]$ is the variance of x (Harnett, 1982). Intuitively, if one multiplies the mean of a distribution by some scalar k , the variance of that distribution expands or shrinks by the square of that scalar value. However, if instead of scaling the mean, one changes its value by adding or subtracting some constant, then the distribution shifts to the right or left on its x -axis, but its variance does not change.

In the context of the mean and variance for the model facilities, to estimate the adjustment of the variance for net income, EPA had to first do the same for EBIT. EPA applied these rules in the following manner:

- EPA first decreased the mean value of EBIT relative to the mean of [value of shipments - (payroll + material costs)] by subtracting from it all other costs; however, the variance for EBIT is unchanged and equals the variance for [value of shipments - (payroll + material costs)].

Conceptually, because it has a smaller mean but an identical variance, the distribution of EBIT will result in a larger probability of negative income relative to the distribution for the [value of shipments - (payroll + material costs)]. In practice, the probability that the [value of shipments - (payroll + material costs)] is less than zero in the four meat products NAICS codes ranges from 22 percent to 26 percent,

while the probability that EBIT is less than zero generally ranges from 26 percent to 30 percent (in some isolated instances, it may be as high as 40 percent).⁸

To estimate net income adjusted variance, EPA then did the following:

- The primary—but not the only—difference between net income and EBIT is tax payments, which are calculated by multiplying EBIT by $(1 - \text{tax rate})$. Therefore, the variance of net income is adjusted by multiplying the variance EBIT by the square of $(1 - \text{tax rate})$.

The probability that model facility net income is less than zero is thus identical to the probability that EBIT is less than zero.

The distribution for estimated cash flow has an identical variance to net income, but a larger mean because depreciation is added to the mean of net income. The probability that cash flow is less than zero tends to be about 3 percent to 5 percent lower than the probability that net income is less than zero.

Had EPA simply scaled the variance for net income and cash flow from the variance of the [value of shipments - (payroll + material costs)], the probability that income was less than zero would be identical for each employment class within each NAICS code regardless of what income measure was used. That probability would also equal the probability that the [value of shipments - (payroll + material costs)] was less than zero, and would range from 22 percent to 26 percent according to NAICS code.

⁸ EPA “smoothed” the estimated variance of the [value of shipments - (payroll + material costs)] by applying the median coefficient of variation (i.e., standard deviation divided by mean) within a NAICS code to all employment classes in that code. This results in an identical probability that income is less than zero for all employment classes within a NAICS code, though that probability differs between NAICS codes. EPA felt smoothing was appropriate because of: (1) relatively small populations in some employment classes, (2) relatively large differences in the coefficient of variation between employment classes within a NAICS code, and (3) the fact that only 12 different model facilities were selected from the 35 total model facilities, potentially increasing the effect of an outlier on the impact analysis.

B.4.5 Effect on Modeling Impacts

There are many reasons why EPA's model results in a high probability of negative baseline income for facilities. First, true facility income may be negative in the baseline, due either to how multifacility companies choose to allocate costs and revenues among facilities or to financial distress. Second, EPA found it necessary to make certain assumptions when modeling a distribution of income for each class rather than single facility. The available data do not make it possible to determine what proportion of facilities will be projected to have negative baseline income results due to each reason.

As one might expect, the percentage of facilities with negative baseline income will increase if: (1) the mean of a distribution decreases while the variance remains constant, or (2) the variance of a distribution increases while the mean remains constant. In both cases, the percentage of facilities with negative baseline income increases because the portion of the distribution's tail lying below zero (i.e., to the left of the \$0 value in Figure B-1) is larger.

The effect of this issue on EPA's projection of economic impacts is not straightforward. The interaction between the mean income and variance of a distribution on the one hand, and the range of estimated compliance costs on the other can be quite complex. Intuitively, one can observe on Figure B-1 that the incremental probability of closure will depend on the slope of the cumulative distribution function between \$0 and the estimated compliance costs. Changes in mean or variance will change the slope of the distribution function where it crosses the \$0 value. However, the net effect on incremental probability will also vary according to the size of the compliance costs. The key point here is that an overestimate of "baseline closures" (i.e., facilities with income less than zero) does not necessarily lead to an underestimate of incremental closures.⁹

⁹ Appendix E contains a sensitivity analysis where EPA used an alternate data source to estimate variance that resulted in a smaller probability of baseline closures.

B.5 LIMITATIONS OF THE MODEL FACILITY APPROACH

EPA based its model economic facilities on Census data, the only high-quality source of both revenue and cost data at a relatively disaggregated level. The limitation this places on the data is that the Census Bureau does not provide data distinguishing different production processes performed within each employment class. All facilities in the 50 to 99 employee class for NAICS 311611, for example, are known to perform red meat slaughtering. However, an unknown percentage of those facilities also perform further processing, rendering, or both. Other things being equal, facilities that perform additional processes will also incur additional production costs and earn additional revenues. The financial data presented by the Bureau will be a weighted average of all those facilities.

The effect of this is as follows. Consider two model engineering facilities with roughly equal full-time equivalent employment. One facility performs cattle slaughtering, the second performs cattle slaughtering, further processing, and rendering. Because both facilities slaughter cattle and have equal employment, both facilities would be assigned identical economic model facilities with identical income measures. The economic model facility would probably overstate operating costs and revenues for the slaughtering facility but understate them for the slaughtering, further processing, and rendering facility (although the net effect on facility income cannot be determined). Other things equal, the second facility (slaughtering, further processing, and rendering) would incur larger compliance costs; measured against the same model facility income, it would also incur larger impacts.

B.6 REFERENCES

Brealey, R. A., and S. C. Meyers. 1996. *Principles of Corporate Finance*, 5th edition. New York: The McGraw-Hill Companies, Inc.

Brigham, E. F., and L. C. Gapenski. 1997. *Financial Management: Theory and Practice*, 8th edition. Fort Worth: The Dryden Press.

Financial Accounting Standards Board. 1996. *Financial Accounting Standards: Explanation and Analysis*. SFAS No. 105 (Disclosure of information about financial instruments with off-balance sheet risk and financial instruments with concentrations of credit risk), No. 107 (Disclosures about fair value of financial instruments), and No. 119 (Disclosure about derivative financial instruments and fair value of financial instruments). Bill D. Jarnagin, ed. 18th edition. Chicago: CCH Incorporated. pp. 564-586.

- Harnett, Donald L. 1982. *Statistical Methods* (3rd ed.). Reading, Massachusetts: Addison-Wesley Publishing.
- Mendenhall, W., D. D. Wackerly, and R. L. Scheaffer. 1990. *Mathematical Statistics with Applications* (4th ed.). Boston: PWS-Kent Publishing Co.
- Quash, 2001. Personal communication from Nishea Quash, U.S. Census Bureau, to Calvin Franz, ERG, September 10, 2001.
- U.S. Census Bureau. 1999a. *Animal (Except Poultry) Slaughtering. EC97M-3116A. 1997 Economic Census: Manufacturing Industry Series*. Washington, D.C.: U.S. Department of Commerce. November.
- U.S. Census Bureau. 1999b. *Meat Processed From Carcasses. EC97M-3116B. 1997 Economic Census: Manufacturing Industry Series*. Washington, D.C.: U.S. Department of Commerce. November.
- U.S. Census Bureau. 1999c. *Poultry Processing. EC97M-3116D. 1997 Economic Census: Manufacturing Industry Series*. Washington, D.C.: U.S. Department of Commerce. November.
- U.S. Census Bureau. 1999d. *Rendering and Meat Byproduct Processing. EC97M-3116C. 1997 Economic Census: Manufacturing Industry Series*. Washington, D.C.: U.S. Department of Commerce. December.
- U.S. Census Bureau. 2001. *Special Tabulation of Census Data for NAICS 311611, 311612, 311613, 311615*. Washington, D.C.: U.S. Department of Commerce. May.
- U.S. EPA. 2002. *Development Document for the Proposed Revisions to the Effluent Limitations Guidelines for the Meat Products Industry*. EPA-821-B-01-007. Washington, D.C.: U.S. Environmental Protection Agency, Office of Water.

APPENDIX C

MARKET MODEL METHODOLOGY

C.1 INTRODUCTION

EPA developed a market model to examine the impacts of the meat products industry effluent guideline on the price and output of various meat products. The distinguishing feature of EPA's market model is that it explicitly incorporates cross-market impacts among meat types into the analysis. The demand for meat products such as beef, pork, broilers, and turkey is closely related; a 1 percent increase in the price of pork, for example, may cause a 0.7 percent fall in the quantity of pork demanded and a 0.2 percent increase in demand for beef.

In the context of EPA's proposed ELG for the meat products industry, this increases the complexity of the market analysis. Because EPA's proposed ELG may simultaneously affect the price of beef, pork, chicken, and turkey, the market analysis for each product depends not only on the compliance costs for that product but on the impact of compliance on the prices of the other three meat products.

For example, if the ELG imposes compliance costs on the producers of beef products, then the supply of beef products will tend to decrease (i.e., the supply curve for beef will shift to the left; a smaller quantity of beef will be offered for sale at the current price). If all other things remained constant, this would tend to increase the price of beef products while decreasing the quantity sold. However, EPA's ELG may also impose compliance costs on pork producers, tending to increase the price of pork. All other things being constant, the increase in the price of pork would increase the demand for beef products; the demand curve for beef will shift to the right. This would tend to increase the price of beef as well as increase the quantity of beef sold. The final impact on the price and output of beef products will depend on the relative magnitude of supply and demand shifts. Figure C-1 illustrates the general rule behind this example.

If all meat products incur relatively similar per-unit compliance costs, cross-market impacts would tend to be roughly offsetting. However, if per-unit compliance costs are asymmetric (e.g., per-unit compliance costs are significantly larger for some subcategories than for others), then potentially

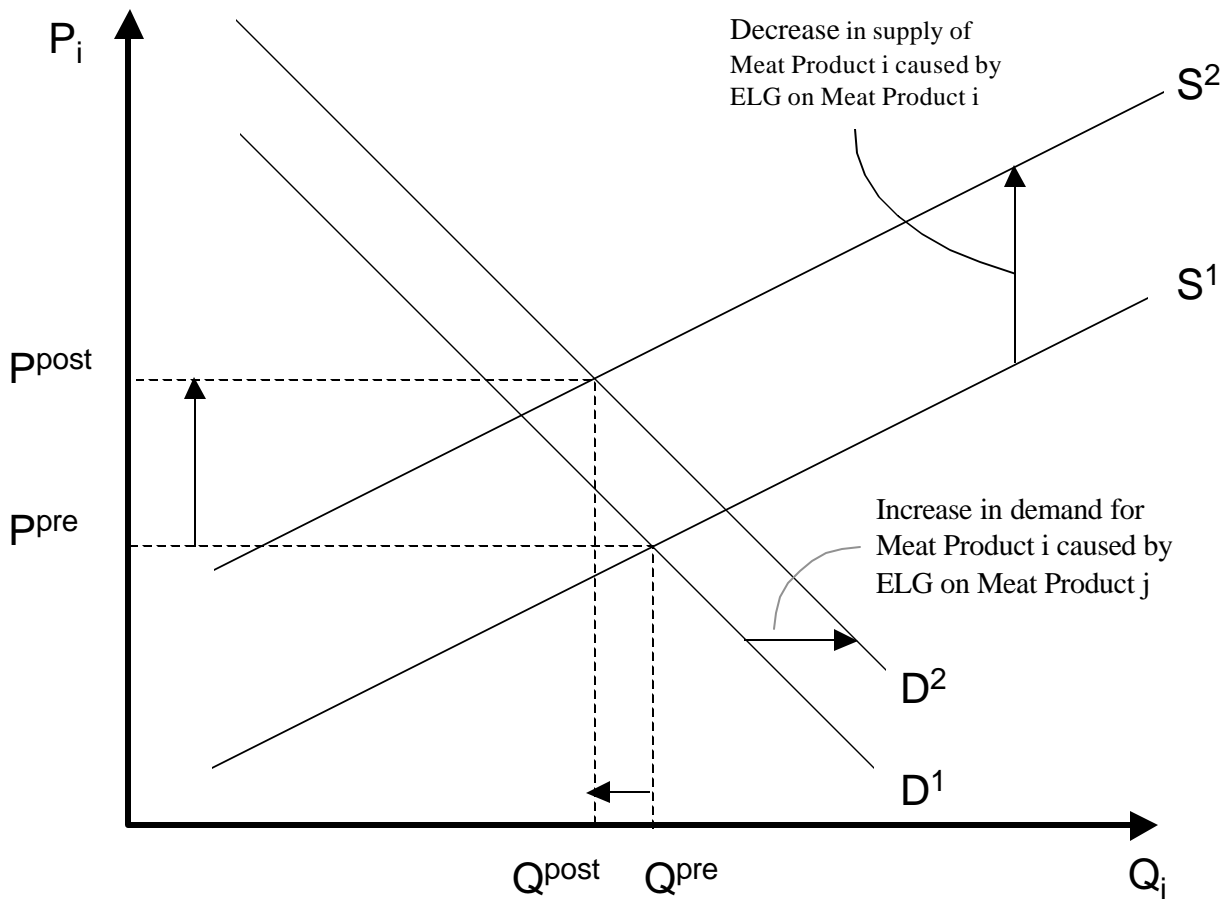

D^1, S^1 = preregulatory market supply and demand conditions
 D^2, S^2 = postregulatory market supply and demand conditions
 P_{pre}, Q_{pre} = preregulatory equilibrium price and quantity
 P_{post}, Q_{post} = postregulatory equilibrium price and quantity

Figure C-1

Impact of the Effluent Guideline on Market for Meat Product i

significant shifts could occur between meat product markets. EPA's model was developed with the flexibility to analyze the latter situation as well as the former.

In order to incorporate both cross-market effects and international trade into the model, EPA specified linear supply and demand equations in each market to make the model tractable. The slopes of the equations were derived from estimated price elasticities of supply and demand found in existing research. These elasticities were then converted to slopes at the baseline equilibrium price and quantity. Because domestic supply, domestic demand, import supply, and export demand are all specified as linear functions, the model components are additive, and simultaneous equilibrium can be solved for in multiple markets using linear algebra.

Of major concern to observers of the meat product industry is the issue of potential market power. EPA selected a perfectly competitive structure for the meat products market model after performing an extensive literature search. EPA found that most researchers were unable to reject the existence of perfectly competitive markets in the beef and pork markets; in the poultry market, market power was found to exist for meat processors vis-a-vis livestock suppliers, but not against customers in the output market. The results of this literature search are presented in the industry profile.

Section C.2 presents the basic market model specification and solution. Section C.3 discusses data sources for the model.

C.2 MARKET MODEL APPROACH

First, standard domestic supply, domestic demand, import supply, and export demand equations are developed for each meat product. These equations express quantity as a linear function of a product's domestic price. The linear function's slope is expressed by a price parameter, derived from elasticities in the literature. Domestic demand for each meat product is specified as a function of the price of the other three meat products in addition to its own price. For the market for each meat product to be in equilibrium, U.S. domestic demand for a meat product and foreign demand for U.S. production of that meat product (exports) must be equal to U.S. domestic supply of the product and foreign sales of that product to the U.S.

(imports) at its current market price. This equilibrium condition is used to derive an excess demand function for each meat product.

Second, the excess demand equations are solved. Because the excess demand function for each meat product is linear, expressing the equations for the four meat products in matrix form results in a convenient way to solve the equations simultaneously. Given pre-regulatory prices, quantities, and price parameters, linear algebra is used to solve for the pre-regulatory intercept for all four excess demand equations.

Third, the supply curve shift for each meat product is calculated. (Imposing ELGs on the industry causes the supply curve for each meat product to shift.) The supply curve shift for a meat product is estimated as a function of average per-unit compliance costs for that product. Once the post-regulatory (i.e., post-shift) supply curve is estimated, the excess demand equation for each meat product is re-written.

Fourth, the post-regulatory excess demand equations for all four meat products—like the pre-regulatory equations—are expressed in matrix form. The post-regulatory intercept for each excess demand equation, however, is already known: it is a function of the pre-regulatory intercept, per-unit compliance costs, and the supply equation price parameter. By using linear algebra to invert the matrix containing the price parameters, then multiplying the post-regulatory intercept vector by that inverted matrix, EPA can evaluate the set of meat prices that results in simultaneous equilibrium for all four meat products.

Finally, the individual component equations for each meat product's domestic supply, domestic demand, import supply, and export demand are evaluated using the post-regulatory prices to solve for post-regulatory quantities. Changes in these four quantities for each meat product, as well as changes in the price of each meat product, measure the market-level impacts of a meat products effluent guideline.

Each of the steps used to model market-level impacts is described in detail below.

C.2.1. Development of Excess Demand Functions for Individual Meat Products

EPA modeled the market for each of the four meat products: beef (B), pork (P), chicken (C), and turkey (T) using four linear equations:

$$Q_i^D = \alpha_{Di} + d_{ii}P_i + \sum_{i \neq j} d_{ij}P_j$$

$$Q_i^S = \alpha_{Si} + s_{ii}P_i$$

$$Q_i^X = \alpha_{Xi} + x_iP_i$$

$$Q_i^M = \alpha_{Mi} + m_iP_i$$

where the U.S. domestic quantity demanded of meat product i , Q_i^D , is a function of both the U.S. domestic price of meat product i , P_i , and the U.S. domestic price of other meat products j , P_j . U.S. domestic supply of meat product i , Q_i^S , is modeled as a function of domestic price, P_i , only, as are “rest-of-the-world” (ROW) demand for U.S. meat product i , Q_i^X (exports), and U.S. demand for ROW meat product i , Q_i^M (imports). Clearly, each meat product’s supply and demand (both domestic and foreign) depend on the price of many other factors as well as its own price (and the price of other meat products in the case of domestic demand). However, because EPA is holding the prices of these other factors constant for the purposes of this analysis, it is not necessary to explicitly represent them in the relevant equation.

The parameters d_{ij} , s_{ii} , x_i , and m_i represent the slopes of their respective functions (i.e., the change in quantity of product i for a given change in the price of product i). The d_{ij} parameters shift the demand curve (the change in demand for product i for a given change in the price of product j —holding P_i constant). The parameters α_{Di} , α_{Xi} , α_{Si} , and α_{Mi} are the intercepts of their respective equations.

The values for the domestic demand equation slope and shift parameters are estimated from published estimates of own- and cross-price demand elasticities. One linearizes these elasticities by multiplying the elasticity by baseline quantity and dividing by baseline price. Thus, if:

$$\varepsilon_{ij} = \frac{\partial Q_i^D}{\partial P_j} \frac{P_j}{Q_i^D}$$

then:

$$d_{ij} = \frac{\partial Q_i^D}{\partial P_j} = \frac{Q_i^D}{P_j} \varepsilon_{ij}$$

where ε_{ij} is the elasticity of demand for product i with respect to the price of product j , and both quantity demanded (Q_i^D) and price (P_i) are set equal to their baseline values.

Similarly, the slopes of domestic supply, s_i , import supply, m_i , and export demand, x_i , functions can be defined as:

$$s_{ii} = \frac{\partial Q_i^S}{\partial P_i} = \frac{Q_i^S}{P_i} \gamma_{ii}$$

$$m_i = \frac{\partial Q_i^M}{\partial P_i} = \frac{Q_i^M}{P_i} \eta_{mi}$$

$$x_i = \frac{\partial Q_i^X}{\partial P_i} = \frac{Q_i^X}{P_i} \eta_{xi}$$

where γ_{ii} , η_{xi} , and η_{mi} are elasticities with respect to U.S. domestic price.

In equilibrium, U.S. demand for meat product i (Q_i^D) and foreign demand for U.S. meat product i (Q_i^X) must be equal to U.S. supply of meat product i (Q_i^S) and foreign sales of meat product i to the U.S. (Q_i^M) at the current market price for meat product i :

$$Q_i^D + Q_i^X = Q_i^S + Q_i^M$$

This can then be expressed as an excess demand equation for meat product i:

$$Q_i^D + Q_i^X - Q_i^S - Q_i^M = 0$$

or:

$$(\alpha_{Di} + d_{ii}P_i + \sum_{i \neq j} d_{ij}P_j) + (\alpha_{Xi} + x_iP_i) - (\alpha_{Si} + s_{ii}P_i) - (\alpha_{Mi} + m_iP_i) = 0$$

Simplifying the excess demand function for each meat product, and making a notational substitution for convenience, results in:

$$(\alpha_{Di} + \alpha_{Xi} - \alpha_{Si} - \alpha_{Mi}) + (d_{ii} + x_i - s_{ii} - m_i)P_i + \sum_{i \neq j} d_{ij}P_j = 0$$

$$\pi_i + \lambda_i P_i + \sum_{i \neq j} d_{ij} P_j = 0$$

The solution for the intercept of the individual meat product excess demand function is:

$$\lambda_i P_i + \sum_{i \neq j} d_{ij} P_j = -\pi_i$$

C.2.2 Simultaneous Solution of Pre-Regulatory Excess Demand Equations

To solve the excess demand equations for all four meat products simultaneously, one writes the equations in matrix form:

$$\begin{bmatrix} \lambda_B & d_{BP} & d_{BC} & d_{BT} \\ d_{PB} & \lambda_P & d_{PC} & d_{PT} \\ d_{CB} & d_{CP} & \lambda_C & d_{CT} \\ d_{TB} & d_{TP} & d_{TC} & \lambda_T \end{bmatrix} \begin{bmatrix} P_B \\ P_P \\ P_C \\ P_T \end{bmatrix} = \begin{bmatrix} -\pi_B \\ -\pi_P \\ -\pi_C \\ -\pi_T \end{bmatrix}$$

If this is expressed in vector notation as $A \cdot P = \Pi$, the intercept for each excess demand equation, π_i , can be solved for using known prices and values for the price parameter elements of the A matrix.

C.2.3 Post-Regulatory Excess Demand Functions

The imposition of regulatory costs causes a decrease in the supply of each meat product for which an effluent guideline is developed. If δ_i represents the per unit compliance costs for meat product i, the post-regulatory supply curve is:

$$Q_i^S = \alpha_{Si} + s_{ii}(P_i - \delta_i)$$

Substituting the post-regulatory supply curve into the excess demand function and rearranging it (using the notation-simplifying substitutions), the excess demand for each product i is:

$$\lambda_i P_i + \sum_{i \neq j} d_{ij} P_j = -s_{ii} \delta_i - \pi_i$$

C.2.4 Simultaneous Solution of Post-Regulatory Excess Demand Functions

The post-regulatory excess demand functions for each meat product are again placed in matrix form to solve the system of equations for the set of post-regulatory prices that generate equilibrium in all four markets simultaneously. The system of simultaneous equations is:

$$\begin{bmatrix} \lambda_B & d_{BP} & d_{BC} & d_{BT} \\ d_{PB} & \lambda_P & d_{PC} & d_{PT} \\ d_{CB} & d_{CP} & \lambda_C & d_{CT} \\ d_{TB} & d_{TP} & d_{TC} & \lambda_T \end{bmatrix} \begin{bmatrix} P_B \\ P_P \\ P_C \\ P_T \end{bmatrix} = \begin{bmatrix} -s_{BB}\delta_B - \pi_B \\ -s_{PP}\delta_P - \pi_P \\ -s_{CC}\delta_C - \pi_C \\ -s_{TT}\delta_T - \pi_T \end{bmatrix}$$

In this set of simultaneous equations, the elements of matrix A are known (e.g., λ_i , d_{ij}), as are the elements of the new vector Π^* (e.g., s_{ii} , δ_i , π_i). The set of meat product prices that will result in equilibrium in all four meat product markets can be solved for by multiplying the vector Π^* by the inverse of the A matrix (i.e., $P' = A^{-1}\Pi^*$).

C.2.5 Post-Regulatory Price and Quantities

The new equilibrium price for each meat product, P_i' , is substituted back into the component equations to solve for the post-regulatory domestic demand, $Q_i^{D'}$, domestic supply, $Q_i^{S'}$, export demand, $Q_i^{X'}$, and import supply, $Q_i^{M'}$, for each meat product:

$$\alpha_{Di} + d_{ii}P_i' + \sum_{i \neq j} d_{ij}P_j' = Q_i^{D'}$$

$$\alpha_{Si} + s_{ii}(P_i' - \delta_i) = Q_i^{S'}$$

$$\alpha_{Xi} + x_iP_i' = Q_i^{X'}$$

$$\alpha_{Mi} + m_iP_i' = Q_i^{M'}$$

The changes in market price ($P_i - P_i'$), domestic demand, ($Q_i^D - Q_i^{D'}$), domestic supply, ($Q_i^S - Q_i^{S'}$), export demand, ($Q_i^X - Q_i^{X'}$), and import supply, ($Q_i^M - Q_i^{M'}$) for each meat product are the projected market-level impacts of the effluent guideline.

C.3 DATA SOURCES FOR MARKET MODEL ANALYSIS

Following is an evaluation of potential publicly available data sources for baseline values and key parameters.

C.3.1 Baseline Market Quantities and Prices

EPA examined a number of possible sources for baseline quantity and price data. Of these, the three most important are:

- *Economic Census of Manufacturers*, which provides both value and quantity data for a fraction of 1997 industry shipments at the 10-digit product level. The transactions price can be calculated for those products with both value and quantity data. Use of Census data limits the baseline to 1997, because the *Annual Survey of Manufactures* provides only on value of shipments, and there is no *Current Industrial Report* for meat products. For these products, data are available on both value and quantity of shipments as a percent of value of industry shipments:¹
 - Beef: 27.4 percent of combined Animal Slaughtering and Processing Industries (NAICS 311611 and 311612; Census, 1999a and 1999b), including boxed beef.
 - Pork: 11.4 percent of the combined Animal Slaughtering and Processing Industries (NAICS 311611 and 311612; Census, 1999a and 1999b).
 - Chicken: 39.9 percent of Poultry (NAICS 311615; Census, 1999c).

¹ Dividing value data by quantity results in the transactions price of the product, thus both are necessary to determine baseline price and output. In the combined Animal Slaughtering and Processing industries (NAICS 311611 and 311612), 20.8 percent of products had both value and quantity data, but could not be classified by meat type; 25.3 percent of products with price and quantity data in the Poultry industry could not be classified by meat type. For Animal Slaughtering and Processing, 40.4 percent of products had value data only, while 22.6 percent of Poultry products had only value data. No products in Rendering (NAICS 311613; Census, 1999d) had both value and quantity data.

— Turkey: 12.2 percent of Poultry (NAICS 311615; Census, 1999c).

- USDA *Livestock, Dairy and Poultry Situation and Outlook* (Outlook), which provides quantity and price data for relatively aggregated meat products: carcass weight of beef and pork, ready-to-cook (RTC) weight for broilers and turkeys.² Prices are for selected wholesale and retail products. Outlook also provides the carcass and RTC weight for both imports and exports of meat products at the same level of aggregation through USDA's Foreign Agricultural Trade of the United States (FATUS) database.³ Data for 1995 through 2000 were obtained from the USDA Web site.
- USDA *Food Consumption, Prices, and Expenditures, 1970–97* (Putnam and Allshouse, 1999), which provides quantity of meat products by carcass weight (RTC weight for poultry), retail weight, and boneless weight.⁴ Carcass, RTC, and trade weights reported are generally within 1 percent of those reported in Outlook. Interestingly, this source cites small quantities of broiler and turkey imports (e.g., 5 million pounds, RTC weight for broilers, less than 0.02 percent of domestic production), while both Outlook and the FATUS database report no imports for these two meat products. This report also provides the Bureau of Labor Statistics' Consumer Price Index and average annual retail price at a more detailed level than does Outlook.

Table C-1 presents baseline output data by meat type for 1997 from all three sources; it also presents estimated transactions prices from Census data and selected average wholesale and retail prices from Outlook and Putnam. Although the Census production data differ significantly from the carcass weight values reported in Outlook and Putnam, with the exception of pork, the Census data is reasonably similar to Putnam's retail and boneless weight figures.

EPA selected Outlook data for the baseline price and quantity. Although EPA's first choice would have been to use Census data where the price could be calculated as each product's transactions price

² Carcass weight of beef is defined as the chilled, hanging carcass, including the kidney and attached internal fat (kidney, pelvic, and heart fat), but not the skin, head, feet, and unattached internal organs. Carcass weight of pork is defined as the chilled, hanging carcass, including the skin and feet, but excluding the kidney and attached internal fat. RTC weight of poultry consists of the entire dressed bird, including bones, skin, fat, liver, heart, gizzard, and neck (Putnam, 1999).

³ The trade data for beef include veal; domestic production of veal is recorded separately.

⁴ Retail and boneless weights adjust for those parts of the carcass not generally bought by consumers. These are not directly calculated, but instead are estimated using conversion factors. For beef, retail weight is 70 percent, and boneless weight is 67 percent, of carcass weight. For pork, retail weight is 78 percent, and boneless weight is 73 percent, of carcass weight. For broilers, retail weight is 87 percent, and boneless weight is 61 percent, of RTC weight. For turkeys, boneless weight is 79 percent of RTC weight (Putnam, 1999).

Table C-1
1997 Baseline Quantity and Price Data for Market Model

Data Source	Meat Product			
	Beef	Pork	Chicken	Turkey
U.S. Domestic Production (millions of pounds)				
1997 U.S. Census	15,133	5,720	21,180	4,119
USDA Outlook: Carcass/RTC Weight	25,384	17,244	27,271	5,478
USDA FCPA:				
Carcass/RTC Weight	25,490	17,242	27,041	5,412
Retail Weight	17,843	13,380	23,499	NA
Boneless Weight	17,053	12,569	16,441	4,275
U.S. Imports (millions of pounds)				
1997 U.S. Census	NA	NA	NA	NA
USDA Outlook: Carcass/RTC Weight	2,343	633	NA	NA
USDA FCPA: Carcass/RTC Weight	2,343	633	5	1
U.S. Exports (millions of pounds)				
1997 U.S. Census	NA	NA	NA	NA
USDA Outlook: Carcass/RTC Weight	2,136	1,044	4,664	606
USDA FCPA: Carcass/RTC Weight	2,136	1,044	4,664	598
Representative U.S. Domestic Prices				
1997 U.S. Census: Transactions Price	\$1.323	\$1.454	\$0.584	\$0.915
USDA Outlook: Average Wholesale Price				
Beef, Central, Boxed, Choice, 550–700 lb.	\$1.033			
Beef, Central, Boneless, 90% Fresh	\$0.908			
Pork, Central, Cutout, Composite		\$0.709		
Pork, Central, Loins, 14–19 lb., Bl 1/4" trim		\$1.081		
Broilers, 12 City Average			\$0.588	
Broilers, Northeast, Boneless Breast			\$1.720	

Table C-1 (cont.)
1997 Baseline Quantity and Price Data for Market Model

Data Source	Meat Product			
	Beef	Pork	Chicken	Turkey
Turkey, Eastern, Hens, 8–16 lb.				\$0.649
Turkey, Eastern, Drumsticks				\$0.311
USDA FCPA: Average Retail Price				
Ground Beef, 100% Beef	\$1.40			
Chuck Roast, Choice, Boneless	\$2.43			
Sirloin Steak, Choice, Boneless	\$4.21			
Bacon, Sliced		\$2.68		
Chops, Center Cut, Bone-in		\$3.48		
Ham, Boneless, Excluding Canned		\$2.79		
Sausage, Fresh, Loose		\$2.15		
Chicken, Fresh, Whole			\$1.00	
Chicken, Breast, Bone-in			\$2.04	
Turkey, Frozen, Whole				\$1.05

weighted by output share, too many observations were missing in the Census data. Outlook's primary advantage over Putnam's data is that it is more up to date.⁵ Given the highly aggregated nature of Outlook data, and given that the Outlook data are tracked at the carcass weight level, EPA selected Outlook's wholesale price measures to use as baseline price; these are best interpreted as indicator prices rather than the explicit price of all output. EPA determined that Putnam's retail price measures were not linked closely enough to the carcass weight output to be suitable for use as the baseline prices.

C.3.2 Compliance Costs

In order to estimate the supply curve shift for each meat type, EPA calculated average compliance costs per unit of output. Conceptually, per-unit compliance costs for each meat type are simply the sum of annualized compliance costs divided by meat output.

EPA initially estimated compliance costs by process (first, further, and rendering) within general meat type categories (e.g., red meat and poultry). This meant that EPA had to attribute (1) estimated compliance costs for red meat to beef and pork and (2) estimated compliance costs for poultry to chicken and turkey. To do this, EPA first estimated total annualized compliance costs for each subcategory and size class (e.g., red meat, further processors, medium size). Then, for each subcategory size class, EPA calculated the quantity and percent of total meat production accounted for by each meat type (beef, pork, chicken, and turkey). Costs were attributed by the percent each meat type made up of total meat production for that subcategory size class (e.g., if red meat, further processors, medium sized facilities produced 70 percent beef, 70 percent of annualized compliance costs for that subcategory size class would be attributed to beef). Per-unit costs were estimated by dividing the attributed compliance costs for each meat type by the quantity of that meat type produced.

To determine the average per-unit compliance costs for each meat type over all subcategories and size classes, EPA took a weighted average of the per-unit costs for each subcategory and size class by meat

⁵ Putnam cites small quantities of broiler and turkey imports (e.g., 5 million pounds, RTC weight for broilers, less than 0.02 percent of domestic production), while both Outlook and the FATUS database report no imports for these two meat products. EPA used Putnam's import quantity data for chicken and turkey rather than Outlook's data.

type. The weights were calculated as the meat type output within each subcategory and size class expressed as a percent of total output of that meat type over all subcategories and size classes. (Note that, to an estimation of market-level compliance costs per unit, the distinction between direct and indirect dischargers is irrelevant.) Finally, to estimate market-level impacts, EPA entered average per-unit compliance costs by meat type directly into the market model.

C.3.3 Price Elasticities

C.3.3.1 Price Elasticities of Demand

Domestic price elasticities of demand are widely available from a variety of sources, including USDA and academic research. The results of the literature search for demand elasticities is documented in the record. For use in its market model, EPA selected K. S. Huang's *A Complete System of U.S. Demand for Food* (1993).

The advantage of Huang's estimates is that they were generated in a single, coherent, consistent framework that satisfies theoretical constraints of symmetry, homogeneity, and Engel aggregation. This should make using them better than selecting individual elasticities from among several sources with varying methodologies, degrees of aggregation, and time horizons. The internal consistency of Huang's work is of particular importance because EPA is modeling cross-product impacts in the market model. The own- and cross-price elasticities of demand are presented in Table C-2.

C.3.3.2 Price Elasticities of Supply

EPA undertook a literature search for estimates of the price elasticities of meat supply for both the feedlots and meat products effluent limitations guideline (ELG). This search resulted in a wide range of estimated elasticities with little apparent consensus.

Table C-2
Price Elasticities of Supply and Demand Identified in Feedlots Literature Searches

Sector	Range of Estimated Price Elasticity of Livestock Supply ^a			Range of Estimated Price Elasticity of Meat Demand			Cross Price Elasticities of Meat Demand			
	Low Value	Selected Value	High Value	Low Value ^a	Selected Value ^b	High Value ^a	Beef	Pork	Broilers ^c	Turkey
Beef	-0.170	1.020	3.240	-2.590	-0.621	-0.150	NA	0.114	0.018	0.004
Pork	0.007	0.628	0.628	-1.234	-0.728	-0.070	0.192	NA	0.013	0.013
Broilers	0.064	0.200	0.587	-1.250	-0.372	-0.104	0.103	0.047	NA	-0.023
Turkey	0.210	0.200	0.518	-0.680	-0.535	-0.372	0.089	0.141	-0.077	NA

^a Based on literature reviews; “selected” supply elasticities represent a consensus of expert opinion for CAFOs market model.

^b Source: Huang, 1993.

Table C-3
EPA Estimates of Armington Trade Elasticities With Respect to Domestic Price

Sector	Elasticity of Meat Imports w.r.t. Domestic Price				Elasticity of Meat Exports w.r.t. Domestic Price			
	Domestic Demand Elasticity ^a	U.S. Imports As Percent of U.S. Market ^b	Armington Elasticity (ξ) ^c	Import Elasticity	Domestic Demand Elasticity ^a	U.S. Exports As Percent of ROW Market ^b	Armington Elasticity (ξ) ^c	Export Elasticity
Beef	-0.621	9.17%	1.580	0.097	-0.621	2.20%	1.580	-1.558
Pork	-0.728	3.90%	1.580	0.035	-0.728	0.64%	1.580	-1.575
Broilers	-0.372	0.02%	1.249	0.000	-0.372	5.12%	1.249	-1.202
Turkey	-0.535	0.02%	1.249	0.000	-0.535	8.04%	1.249	-1.187

^a Source: Huang, 1993.

^b EPA calculation based on United Nations Food and Agriculture Organization (UNFAO) data.

^c Source: Gallaway et al., 2000.

EPA undertook a literature search for estimates of the price elasticities of meat supply for both the feedlots and meat products ELGs. This search resulted in a wide range of estimated elasticities with little apparent consensus.

Because of this lack of consensus, EPA decided to use the elasticities from the ELG for concentrated animal feeding operations (CAFOs). These elasticities were selected for the CAFOs model with the concurrence of EPA's expert consultants (U.S. EPA, 2001). It is reasonable to use these elasticities for the meat products market model, because meat (in the form of both live animals for slaughter and meat products) makes up the majority of material costs in the meat products industry (79 percent in animal slaughtering, 63 percent in meat processing, and 76 percent in poultry (U.S. Census Bureau, 1999a through 1999d). In addition, the other major cost component of meat production is unskilled labor, and the price elasticity of primarily unskilled supply tends to be large. Thus, the CAFOs supply elasticities should represent a reasonable lower-bound estimate for the price elasticity of meat supply. The supply elasticities selected for use in the model are presented in Table C-2.

C.3.3.3 Import and Export Elasticities With Respect to U.S. Domestic Price

EPA used an Armington-type specification to model the effects of international trade on U.S. meat products markets. If foreign-produced and domestically produced goods are perceived as perfect substitutes for each other—that is, if consumers do not differentiate between foreign- and domestically produced goods—then one would expect a country to either import those good or export them, but not to both import and export them simultaneously. However, if consumers perceive foreign and domestically produced goods in a particular class as close but not perfect substitutes, then their country may import and export that class of products simultaneously. The U.S. both imports and exports meat products; the Armington specification that EPA selected incorporates product differentiation in the meat products industry market model.

Econometrically, the Armington model measures the degree of substitutability between traded products. This is expressed as the percentage change in market share of the imported product relative to the domestically produced good caused by a change in the relative prices of the imported and domestic goods. An elasticity of zero implies that consumers will not substitute imported meat products for domestic meat

products; the higher the elasticity, the more willing consumers are to make this substitution. This means that if the elasticity of substitution is equal to one, then market shares remain constant; if this elasticity is greater than one, then an increase in U.S. price means that U.S. market share will decrease (Armington, 1969a).

The Armington elasticity of substitution cannot be directly used in EPA’s market model. However, Armington demonstrated that own price and cross price trade elasticities are a function of domestic demand elasticities, market shares of domestic and foreign products, and the value of the elasticity of substitution (Armington, 1969a, 1969b). This means that EPA could use Armington’s results to derive formulae for the trade elasticities used in its market model.⁶

The U.S. elasticity of demand for imports of meat product *i* with respect to the U.S. product price (η_{mi}) is a function of its domestic elasticity of demand (ϵ_{ii}), the ratio of “rest of world” (ROW) and U.S. market shares (θ^U_U and θ^U_R ; EPA assumed for simplicity that there are only two countries, the U.S., and the ROW, thus $\theta^U_U = 1 - \theta^U_R$), and the elasticity of substitution parameter for the U.S. (ξ^U):

$$\eta_{mi} = \frac{\theta^U_R}{\theta^U_U} (\xi^U + \epsilon_{ii})$$

The expected value of η_{mi} is positive. That is, an increase in the U.S. domestic price of meat products is expected to increase U.S. demand for ROW meat products. The elasticity specified above meets this expectation as long as the elasticity of substitution between U.S. and ROW meat products, ξ^U , is greater than the U.S. domestic price elasticity of demand for U.S. meat products, ϵ_{ii} .

Similarly, EPA estimated the elasticity of ROW demand for U.S. meat products (η_{xi} , e.g., U.S. exports) with respect to U.S. price as:

⁶ Further details of this derivation may be found in the rulemaking record.

$$\eta_{xi} = \left(\frac{\theta_U^R}{\theta_R^R} \right) (\xi^R + \epsilon_{ii}^R) - \xi^R$$

which specifies that the elasticity of ROW demand for U.S. meat products is a function of the ROW demand for ROW meat products (ϵ_{ii}^R), relative market shares (θ_R^R and θ_U^R), and ROW consumers' elasticity of substitution between ROW and U.S. meat products (ξ^R). Because own price elasticity of demand is small, the value of η_{xi} is negative: an increase in U.S. price will decrease U.S. exports.

Due to a lack of data availability, EPA calculated a numerical value for this elasticity assuming that:

- The ROW elasticity of substitution for U.S. meat products is identical to the U.S. elasticity of substitution for ROW meat products (i.e., $\xi^R = \xi^U$).
- The elasticity of ROW demand for meat products with respect to ROW price, ϵ_{ii}^R , equals the elasticity of U.S. demand for meat products with respect to U.S. price, ϵ_{ii} .

Note that because the U.S. share of ROW expenditures on meat products is small, the value of the ROW trade elasticity approaches the value for the elasticity of substitution (i.e., $\eta_{xi} \rightarrow -\xi^R$). Thus, the assumption that the overall elasticity of ROW meat product demand equals the overall elasticity of U.S. meat product demand (i.e., $\epsilon_{ii}^R = \epsilon_{ii}$) is not crucial to the results of the analysis.

Sources for domestic demand elasticities are discussed above. Market shares of meat production were estimated at a consistent level of aggregation using quantity data from the United Nations Food and Agriculture Organization.

Long-run Armington elasticities were obtained from Gallaway et al. (2000). Note that Gallaway estimated elasticities at the 4-digit SIC level for Meat Packing (SIC 2011) and Poultry and Egg Processing (SIC 2015). Because these SIC codes contain more than one product, but do not distinguish between beef and pork (SIC 2011) or chicken and turkey (SIC 2015), EPA used the same elasticity of substitution (ξ) for each product described by a code. EPA did use the own price elasticity and market shares specific to each

meat type in calculating that meat type's trade elasticities. Table C-3 presents a summary of the trade parameters and elasticities with respect to changes in domestic price that were used in the model.

C.4 REFERENCES

- Armington, Paul S. 1969a. A theory of demand for products distinguished by place of production. *International Monetary Fund Staff Papers*. 16(1):159-177.
- Armington, Paul S. 1969b. The geographic pattern of trade and the effects of price changes. *International Monetary Fund Staff Papers*. 16(2):179-199.
- Galloway, Michael P., Christine A. McDaniel, and Sandra A. Rivera. 2000. *Industry-Level Estimates of U.S. Armington Elasticities*. Office of Economics Working Paper. Washington, D.C.: U.S. International Trade Commission. September.
- Huang, K. S. 1993. *A Complete System of U.S. Demand for Food*. Technical Bulletin Number 1821. Washington, D.C.: U.S. Department of Agriculture, Economic Research Service.
- Outlook. Various dates. *Livestock, Dairy and Poultry Situation and Outlook*. Washington, D.C.: U.S. Department of Agriculture, Economic Research Service.
- Putnam, Judith J., and Jane E. Allshouse. 1999. *Food Consumption, Prices, and Expenditures, 1970-97*. Statistical Bulletin Number 965. Washington, D.C.: U.S. Department of Agriculture, Food and Rural Economics Division, Economic Research Service.
- Unnevehr, Laurian J., Miguel I. Gómez, and Philip Garcia. 1998. The Incidence of Producer Welfare Losses from Food Safety Regulation in the Meat Industry. *Review of Agricultural Economics*. 20:186-201.
- UN FAO data: downloaded 2/20/01 from: <http://apps.fao.org/page/collections?subset=agriculture>
Agricultural Production/Livestock Primary & Processed/World+, United States of America/.
- U.S. Census Bureau. 1999a. *Animal (Except Poultry) Slaughtering. EC97M-3116A. 1997 Economic Census: Manufacturing Industry Series*. Washington, D.C.: U.S. Department of Commerce. November.
- U.S. Census Bureau. 1999b. *Meat Processed From Carcasses. EC97M-3116B. 1997 Economic Census: Manufacturing Industry Series*. Washington, D.C.: U.S. Department of Commerce. November.
- U.S. Census Bureau. 1999c. *Poultry Processing. EC97M-3116D. 1997 Economic Census: Manufacturing Industry Series*. Washington, D.C.: U.S. Department of Commerce. November.

U.S. Census Bureau. 1999d. *Rendering and Meat Byproduct Processing. EC97M-3116C. 1997 Economic Census: Manufacturing Industry Series*. Washington, D.C.: U.S. Department of Commerce. December.

U.S. EPA. 2001. *Economic Analysis of the Proposed Revisions to the National Pollutant Discharge Elimination System Regulation and the Effluent Guidelines for Concentrated Animal Feeding Operations*. EPA-821-R-01-001. Washington, D.C.: U.S. Environmental Protection Agency, Office of Water. January.

APPENDIX D

SUMMARY OF DEMAND AND SUPPLY ELASTICITY LITERATURE

D.1 SUMMARY OF PRICE ELASTICITY ESTIMATES

This appendix presents the results of EPA's literature review and the magnitudes of published demand and supply elasticities for the beef, pork, and poultry sectors.

EPA has reviewed the available literature on the demand and supply characteristics of the beef, pork, and poultry markets. These expanded reviews include an annotated summary of each study and are contained in the record (Section 8.3.2). The majority of the models in the literature are based on econometric estimations of various demand and supply system specifications, such as the Almost Ideal Demand System (AIDS) and the Rotterdam model. However, given the prevalence of non-theoretical approaches to estimating demand and supply responses in the literature using such techniques as vector autoregression (VAR), EPA also includes those studies in the tables where applicable.

Table D-1
Demand Elasticities for Beef Products Ranked from the Lowest Estimate to the Highest Estimate

Source	Elasticity Estimate
Eales and Unnevehr (1988)	-2.59 (hamburger)
Capps (1989)	-1.27 (roast beef)
Brester and Wohlgenant (1991)	-1.155 (fed beef)
Heien and Pompelli (1988) ¹	-1.11 (roast)
Moschini and Meilke (1989)	-1.05 (beef)
Huang and Hahn (1995) ¹	-1.036 (high quality beef)
Gao and Shonkwiler (1993) ¹	-1.03 (beef)
Kesavan et. al. (1993) ¹	-1.02 (long-run, beef)
Brester and Wohlgenant (1991)	-1.015 (ground beef)
Ospina and Shumway (1979)	-0.98 (fed beef; Langemeier and Thompson, 1967)
Alston and Chalfant (1993)	-0.98 (beef)
Choi and Sosin (1990)	-0.971 (red meat)
Brester (1996)	-0.96 (ground beef)
Chavas (1983)	-0.916 (beef)
Hahn (1994) ¹	-0.869 (beef)
Eales and Unnevehr (1993)	-0.850 (beef)
Heien and Pompelli (1988) ¹	-0.85 (ground beef)
Moschini, Moro, and Green (1994)	-0.84 (beef)
Ospina and Shumway (1979)	-0.83 (fed beef; Freebairn and Rausser, 1975)
Brester and Wohlgenant (1991)	-0.811 (table-cut beef)
Brester (1996)	-0.80 (table-cut beef)
Wohlgenant (1989)	-0.76 (beef and veal)
Marsh (1992)	-0.742 (retail beef)
Heien and Pompelli (1988) ¹	-0.73 (steaks)
Capps (1989)	-0.72 (steak)

Table D-1 (cont.)
Demand Elasticities for Beef Products Ranked from the Lowest Estimate to the Highest Estimate

Source	Elasticity Estimate
Brester (1996)	-0.70 (beef)
Eales and Unnevehr (1988)	-0.68 (table-cut beef)
Marsh (1991)	-0.66 (choice slaughter beef)
Huang (1993)	-0.6212 (beef and veal)
Huang (1986)	-0.6166 (beef and veal)
Hahn (1988)	-0.58 (beef)
Eales and Unnevehr (1988)	-0.570 (beef)
Ospina and Shumway (1979)	-0.57 (wholesale beef)
Marsh (1992)	-0.536 (farm beef)
Marsh (1992)	-0.495 (wholesale beef)
Arzac and Wilkinson (1979)	-0.49 (fed beef)
Brester and Wohlgenant (1993) ¹	-0.45 (beef)
Huang and Hahn (1995) ¹	-0.401 (manufacturing grade beef)
Capps (1989)	-0.15 (ground beef)

¹ As cited in Hahn (1996a).

Table D-2
Supply Elasticities for Beef Products Ranked from the Lowest Estimate to the Highest Estimate

Source	Elasticity Estimate
Marsh (1994)	-0.17 (short-run, fed cattle)
Ospina and Shumway (1979)	0.06 (steer-heifer fed beef; Folwell and Shapouri, 1977)
Ospina and Shumway (1979)	0.14 (slaughter beef)
Marsh (1994)	0.14 (all beef; Freebairn and Rausser, 1975)
Marsh (1994)	0.14 (fed beef; Shuib and Menkhaus, 1977)
Marsh (1994)	0.200 (wholesale fed beef; Bedinger and Bobst, 1988)
Marsh (1994)	0.23 (fed beef; Langemeier and Thompson, 1967)
Marsh (1994)	0.606 (intermediate run, fed cattle)
Marsh (1994)	0.993 (beef; Tvedt, et. al., 1991)
Marsh (1994)	3.24 (long-run, fed cattle)
Buhr (1993)	9.505 (beef, long-run - 5 years) ¹

¹ The estimate is not comparable to the other elasticity estimates. The reported figure is the impact of a 10 percent change in farm price rather than the standard 1 percent. Given the nonlinear nature of the system, the figure cannot be translated into a standard elasticity estimate via division by 10.

Table D-3
Demand Elasticities for Pork Ranked from the Lowest Estimate to the Highest Estimate

Source	Elasticity Estimate
Eales and Unnevehr (1993)	-1.234 (pork - AIDS with SI)
Kesavan et. al. (1993) ¹	-0.99 (pork - long-run)
Gao and Shonkwiler (1993) ¹	-0.95 (pork)
Arzac and Wilkinson (1979)	-0.87 (pork)
Moschini and Meilke (1989)	-0.839 (pork)
Huang and Hahn (1995) ¹	-0.838 (pork)
Huang (1994)	-0.8379 (pork)
Capps (1989)	-0.8279 (pork loin)
Eales and Unnevehr (1993)	-0.801 (pork - AIDS without SI)
Lemieux and Wohlgenant (1989)	-0.80 (pork)
Hahn (1988)	-0.784 (pork)
Brester and Wohlgenant (1991)	-0.779 (pork - ground beef model)
Brester and Wohlgenant (1991)	-0.775 (pork - nonfed model)
Eales and Unnevehr (1988)	-0.762 (pork - aggregate system)
Huang (1986)	-0.7297 (pork)
Huang (1993)	-0.7281 (pork)
Chavas (1983)	-0.723 (pork - SC)
Chavas (1983)	-0.714 (pork - WSC)
Capps (1989)	-0.7005 (pork chops)
Moschini, Moro, and Green (1994)	-0.68 to -0.72 (pork)
Hahn (1994) ¹	-0.699 (pork)
Brester and Schroeder (1995)	-0.69 (pork)
Eales and Unnevehr (1988)	-0.565 (pork - disaggregated system)
Eales et. al. (1998)	-0.52 (pork)
Wohlgenant (1989)	-0.51 (pork - unrestricted)
Capps and Schmitz (1991)	-0.4510 (pork)

Table D-3 (cont.)
Demand Elasticities for Pork Ranked from the Lowest Estimate to the Highest Estimate

Source	Elasticity Estimate
Wohlgenant (1989)	-0.36 (pork - restricted)
Capps (1989)	-0.3596 (ham)
Capps (1989)	-0.2639 (composite pork commodity)
Alston and Chalfant (1993)	-0.17 (pork - Rotterdam)
Alston and Chalfant (1993)	-0.07 (pork - AIDS)

¹ As cited in Hahn (1996a).

Table D-4
Supply Elasticities for Pork Ranked from the Lowest Estimate to the Highest Estimate

Source	Elasticity Estimate
Short-Run	
Holt and Johnson (1988)	0.007 (pork, short-run - 3 quarters)
Heien (1975)	0.09 (pork) ¹
Meilke et. al. (1974)	0.16 (hog, short-run - GDL)
Meilke et. al. (1974)	0.17 (hog, short-run - PDL)
Lemieux and Wohlgenant (1989)	0.4 (pork, short-run)
Buhr (1993)	2.63 (pork, short-run - 1 quarter) ²
Intermediate-Run	
Meilke et. al. (1974)	0.24 (hog, intermediate-run - PDL)
Holt and Johnson (1988)	0.338 (pork, intermediate-run - 10 quarters)
Lemieux and Wohlgenant (1989)	1.8 (pork, intermediate-run)
Long-Run	
Meilke et. al. (1974)	0.43 (hog, long-run - GDL)
Meilke et. al. (1974)	0.48 (hog, long-run - PDL)
Holt and Johnson (1988)	0.628 (pork, long-run - 40 quarters)
Buhr (1993)	7.35 (pork, long-run - 5 years) ²

¹ The reported figure is the elasticity of total number of pigs slaughtered with respect to the ratio of farm to retail price of pork.

² The estimate is not comparable to the other elasticity estimates. The reported figure is the impact of a 10 percent change in farm price rather than the standard 1 percent. Given the nonlinear nature of the system, the figure cannot be translated into a standard elasticity estimate via division by 10.

Table D-5
Demand Elasticities for Broilers/Chickens Ranked from the Lowest to the Highest Estimate

Source	Elasticity Estimate
Kesavan et. al. (1993) ¹	-1.25 (chicken - long-run)
Arzac and Wilkinson (1979)	-0.98 (chicken)
Alston and Chalfant (1993)	-0.94 (chicken - AIDS and Rotterdam)
Eales and Unnevehr (1988)	-0.677 (chicken - whole bird)
Capps (1989)	-0.6557 (chicken)
Eales and Unnevehr (1988)	-0.610 (chicken - parts/processed)
Huang (1986)	-0.5308 (chicken)
Gao and Shonkwiler (1993) ¹	-0.47 (chicken)
Huang (1993)	-0.3723 (chicken)
Hahn (1994) ¹	-0.299 (chicken)
Eales and Unnevehr (1988)	-0.276 (chicken)
Eales and Unnevehr (1993)	-0.233 (chicken - AIDS with SI)
Huang and Hahn (1995) ¹	-0.197 (broiler)
Huang (1994)	-0.1969 (broiler)
Eales and Unnevehr (1993)	-0.162 (chicken - AIDS without SI)
Eales et. al. (1998)	-0.15 (chicken - Model 3)
Eales et. al. (1998)	-0.14 (chicken - Model 1)
Hahn (1988)	-0.140 (chicken)
Eales et. al. (1998)	-0.13 (chicken - Model 2)
Moschini and Meilke (1989)	-0.104 (chicken)

¹ As cited in Hahn (1996a).

Table D-6
Supply Elasticities for Broilers/Chickens Ranked from the Lowest to the Highest Estimate

Source	Elasticity Estimate
Short-Run	
Chavas and Johnson (1982)	0.064 (broiler, short-run)
Chavas (1982)	0.072 (broiler, short-run) ³
Holt and Aradhyula (1990)	0.216 (broiler, short-run-adaptive expectations) ¹
Holt and Aradhyula (1990)	0.232 (broiler, short-run - GARCH) ¹
Aradhyula and Holt (1989)	0.305 (broiler, short-run) ¹
Holt and Aradhyula (1990)	0.399 (broiler, long-run - adaptive expectations) ¹
Buhr (1993)	0.49 (chicken, short-run - 1 quarter) ²
Long-Run	
Holt and Aradhyula (1990)	0.399 (broiler, long-run - adaptive expectations) ¹
Holt and Aradhyula (1990)	0.587 (broiler, long-run - GARCH) ¹
Buhr (1993)	0.68 (chicken, long-run - 5 years) ²

¹ The reported elasticity figure is based on the *expected* rather than the actual mean price of broilers.

² The estimate is not comparable to the other elasticity estimates. The reported figure is the impact of a 10 percent change in farm price rather than the standard 1 percent. Given the nonlinear nature of the system, the figure cannot be translated into a standard elasticity estimate via division by 10.

³ The reported figure is the elasticity of supply with respect to the one-quarter lagged product price.

Table D-7
Demand Elasticities for Turkey Ranked from the Lowest Estimate to the Highest Estimate

Source	Elasticity Estimate
Huang (1986)	-0.6797 (turkey)
Eales et. al. (1998)	-0.63 (turkey - Model 1)
Huang (1993)	-0.5345 (turkey)
Hahn (1994) ¹	-0.459 (turkey)
Soliman (1971)	-0.412 (turkey - 3SLS)
Soliman (1971)	-0.411 (turkey - LISE)
Soliman (1971)	-0.394 (turkey - 2SLS)
Soliman (1971)	-0.372 (turkey - OLS)

¹ As cited in Hahn (1996a).

Table D-8
Supply Elasticities for Turkey Ranked from the Lowest Estimate to the Highest Estimate

Source	Elasticity Estimate
Short-Run	
Chavas and Johnson (1982)	0.210 (turkey, short-run)
Chavas (1982)	0.222 (turkey, short-run) ¹
Soliman (1971)	0.353 (turkey, short-run) ²
Long-Run	
Soliman (1971)	0.518 (turkey, long-run) ²

¹ The reported figure is the elasticity of supply with respect to the one-quarter lagged product price.

² The reported figure is the elasticity of turkey production with respect to the lagged turkey-feed price ratio.

D.2 REFERENCES

- Alston, J.M. and J.A. Chalfant. 1993. The Silence of the Lambdas: A Test of the Almost Ideal and Rotterdam Models. *American Journal of Agricultural Economics*. May.
- Aradhyula, S.V. and M.T. Holt. 1989. Risk Behavior and Rational Expectations in the U.S. Broiler Market. *American Journal of Agricultural Economics*. November.
- Arzac, E.R. and M. Wilkinson. 1979. A Quarterly Econometric Model of United States Livestock and Feed Grain Markets and Some of Its Policy Implications. *American Journal of Agricultural Economics*. May.
- Brester, G.W. 1996. Estimation of the U.S. Import Demand Elasticity for Beef: The Importance of Disaggregation. *Review of Agricultural Economics*. 18(1):31-42. January.
- Brester, G.W. and T.C. Schroeder. 1995. The Impacts of Brand and Generic Advertising on Meat Demand. *American Journal of Agricultural Economics*. 77(4):969-979. November.
- Brester, G.W. and M.K. Wohlgenant. 1991. Estimating Interrelated Demands for Meats Using New Measures for Ground and Table Cut Beef. *American Journal of Agricultural Economics*. 73(4):1182-1194. November.
- Buhr, B. 1993. A Quarterly Econometric Simulation Model of the U.S. Livestock and Meat Sector. University of Minnesota, Department of Agricultural and Applied Economics. Staff Paper P93-12. May. <http://agecon.lib.umn.edu/mn/p93-12.pdf>
- Capps, O. and J.D. Schmitz. 1991. A Recognition of Health and Nutrition Factors in Food Demand Analysis. *Western Journal of Agricultural Economics*. 16(1):21-35. July.
- Capps, O. 1989. Utilizing Scanner Data to Estimate Retail Demand Functions for Meat Products. *American Journal of Agricultural Economics*. 71(3):750-760. August.
- Chavas, J-P. 1983. Structural Change in the Demand for Meat. *American Journal of Agricultural Economics* 65(1):148-153. February.
- Chavas, J-P. 1982. On the Use of Price Ratio in Aggregate Supply Response: Some Evidence From the Poultry Industry. *Canadian Journal of Agricultural Economics*. 64(4):345-358. November.
- Chavas, J-P., and S.R. Johnson. 1982. Supply Dynamics: The Case of U.S. Broilers and Turkeys. *American Journal of Agricultural Economics*. 64(3):558-564. August.
- Choi, S. and K. Sosin. 1990. Testing for Structural Change: The Demand for Meat. *American Journal of Agricultural Economics*. 72(1):227-236. February.
- Eales, J.S., J. Hyde, and L.F. Schrader. 1998. A Note on Dealing with Poultry in Demand Analysis. *Journal of Agricultural and Resource Economics*. 23(2):558-567. December.
- Eales, J. S. and L. J. Unnevehr. 1993. Simultaneity and Structural Change in U.S. Meat Demand. *American Journal of Agricultural Economics*. 75(2):259-268. May.

- Eales, J. S. and L. J. Unnevehr. 1988. Demand for Beef and Chicken Products: Separability and Structural Change. *American Journal of Agricultural Economics*. 70(3):521-532. August.
- Hahn, W.F. 1996a. An Annotated Bibliography of Recent Elasticity and Flexibility Estimates for Meat and Livestock. Washington, DC: U.S. Department of Agriculture, Economic Research Service. Staff Paper 9611. July.
- Hahn, W.F. 1988. Effects of Income Distribution on Meat Demand. *The Journal of Agricultural Economics Research*. 40(2):19-24. Spring.
- Heien, D.M. 1975. An Econometric Model of the U.S. Pork Economy. *The Review of Economics and Statistics*. 57(3):370-375. August.
- Holt, M.T. and S.V. Aradhyula. 1990. Price Risk in Supply Equations: An Application of GARCH Time-Series Models to the U.S. Broiler Market. *Southern Economic Journal*. 57(1):230-242. July.
- Holt, M.T. and S.R. Johnson. 1988. Supply Dynamics in the U.S. Hog Industry. *Canadian Journal of Agricultural Economics*. 36(2):313-335. July.
- Huang, K.S. 1994. A Further Look at Flexibilities and Elasticities. *American Journal of Agricultural Economics*. 76(2):313-317. May.
- Huang, K.S. 1993. A Complete System of U. S. Demand for Food. Technical Bulletin Number 1821. Washington, DC: U.S. Department of Agriculture, Economic Research Service.
- Huang, K.S. 1986. U.S. Demand for Food: A Complete System of Price and Income Effects. Technical Bulletin Number 1714. Washington, DC: U.S. Department of Agriculture, Economic Research Service.
- Lemieux, C.M. and M.K. Wohlgenant. 1989. Ex Ante Evaluation of the Economic Impact of Agricultural Biotechnology: The Case of Porcine Somatotropin. *American Journal of Agricultural Economics*. 71(4):903-914. November.
- Marsh, J.M. 1994. Estimating Intertemporal Supply Response in the Fed Beef Market. *American Journal of Agricultural Economics*. 76(3):444-453. August.
- Marsh, J.M. 1992. USDA Data Revisions of Choice Beef Prices and Price Spreads: Implications for Estimating Demand Responses. *Journal of Agricultural and Resource Economics*. 17(2):323-334.
- Marsh, J.M. 1991. Derived Demand Elasticities: Marketing Margin Methods versus an Inverse Demand Model for Choice Beef. *Western Journal of Agricultural Economics*. 16(2):382-391. December.
- Meilke, K.D., A.C. Zwart, and L.J. Martin. 1974. North American Hog Supply: A Comparison of Geometric and Polynomial Distributed Lag Models. *Canadian Journal of Agricultural Economics*.
- Moschini, G., D. Moro, and R.D. Green. 1994. Maintaining and Testing Separability in Demand Systems. *American Journal of Agricultural Economics*. 76(1):61-73. February.
- Moschini, G. and K.D. Meilke. 1989. Modeling the Pattern of Structural Change in U.S. Meat Demand. *American Journal of Agricultural Economics*. 71(2):253-261. May.

Ospina, E. and C.R. Shumway. 1979. Disaggregated Analysis of Short-run Beef Supply Response. *Western Journal of Agricultural Economics*. 4(2):43-59. December.

Soliman, M.A. 1971. Econometric Model of the Turkey Industry in the United States. *Canadian Journal of Agricultural Economics*. 19:47-60. October.

Wohlgenant, M.K. 1989. Demand for Farm Output in a Complete System of Demand Functions. *American Journal of Agricultural Economics*. 71(2):241-252. May.

APPENDIX E

SENSITIVITY ANALYSES

EPA performed several analyses of the projected impacts reported in Chapter 5 and 6 to determine how sensitive the results are to changes in key assumptions. Section E.1 examines impacts under the alternative assumption that facilities are able to pass through to their customers some percentage of compliance costs in the form of higher prices. Section E.2 looks at the question of baseline closures, and how a potential overestimate of baseline closures may affect results. Finally, Section E.3 determines how projected impacts would differ under the assumption that the distribution of income is not normally distributed, but rather is skewed.

E.1 COST PASS THROUGH

EPA's proposed rule will cause meat processing facilities to incur compliance costs. These increased costs of production will cause a decrease in market supply. Processors will need to realize a higher price per unit in order to sell the same quantity of output after promulgation of the rule that they sold prior to promulgation of the rule.

Figure E-1 illustrates how the proposed rule would affect the market for meat products and how costs are passed through to customers. Compliance costs shift the supply curve upward by an amount equal to the average compliance cost per unit of the proposed rule; this represents the increase in per unit revenues meat processors would have to realize in order to be willing to sell the same quantity of meat products as they sold prior to regulation. Consumers, however, are unwilling to pay that much more to purchase this meat product and the market moves to a new equilibrium at P^{post} , Q^{post} . Price per unit sold is higher than the original market price (P^{pre}) — although not as high as the per unit increase in costs — but

Market for Meat Product i

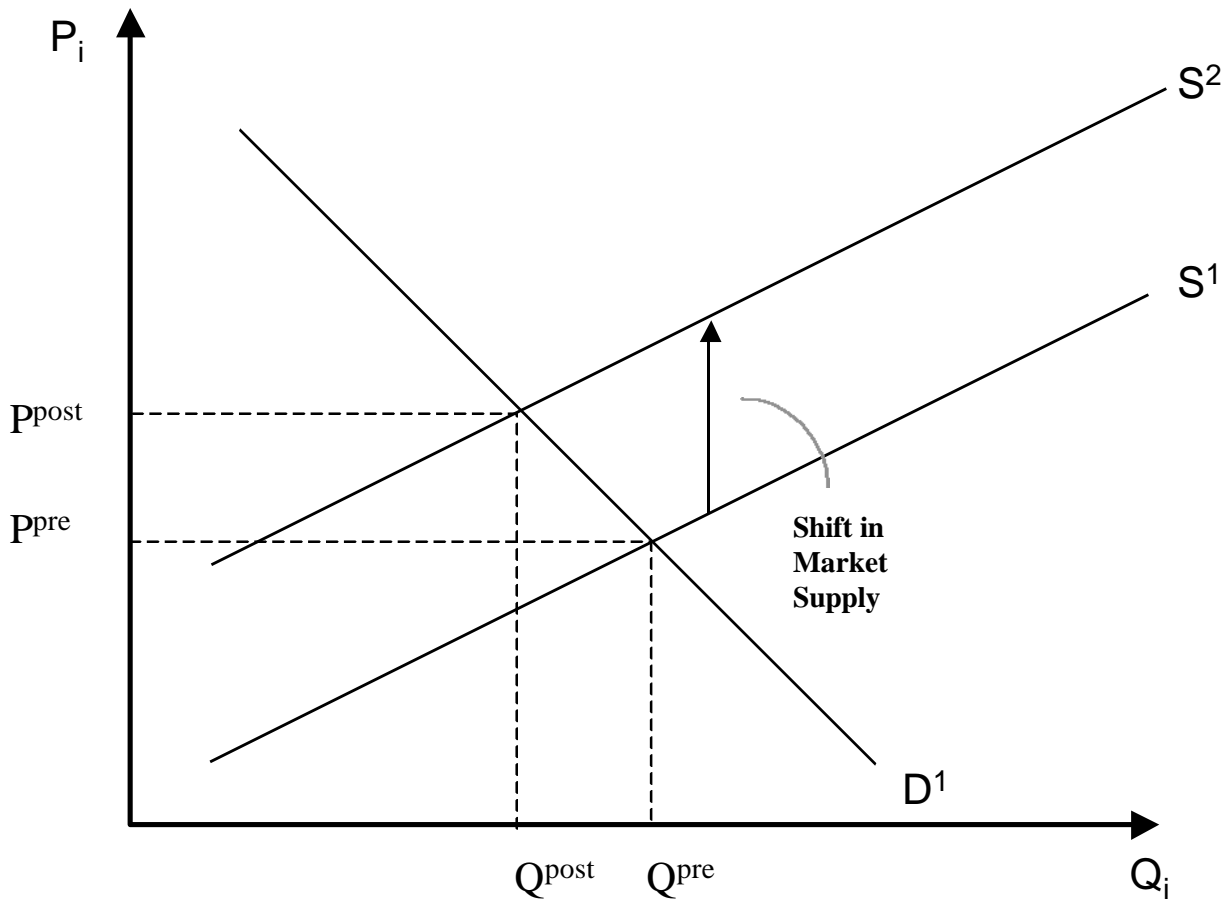

D^1, S^1 = preregulatory market conditions
 D^1, S^2 = postregulatory market conditions
 P^{pre}, Q^{pre} = pre-regulatory equilibrium price and quantity
 P^{post}, Q^{post} = post-regulatory equilibrium price and quantity

Figure E-1

Impact of the Compliance Costs on Market for Meat Product i

fewer unit are sold. Thus, at least some of the costs of the proposed rule incurred by meat processors are partially offset by an increase in price per unit sold. That is cost pass through (CPT).¹

EPA projected facility level impacts in Chapters 5 and 6 under the conservative assumption that CPT is zero. In this sensitivity analysis EPA will project facility level impacts assuming some percentage of compliance costs are passed through to customers in the form of higher prices. EPA will use its market model to determine the percentage of costs that are passed through, multiply compliance costs per facility by one minus that percentage, then project the ratio of compliance costs to net income, the incremental probability of closure, and the number of closures under that scenario.

Conceptually, CPT is measured as described above and as illustrated in Figure E-1:

$$\text{cost pass through} = \frac{(P^{\text{post}} - P^{\text{pre}})}{\text{per unit compliance costs}}$$

The price elasticities of supply and demand determine how much price increases relative to per unit compliance costs. CPT is the percentage of compliance costs paid by consumers in the form of higher prices, therefore the percentage of compliance costs incurred by facilities is equal to one minus the CPT percentage. For example, if CPT is 40 percent, and compliance costs increase per unit costs by \$1, then consumers pay \$0.40 per unit in higher prices, and producers incur \$0.60 per unit in higher costs.

One complication to the calculation of CPT as outlined above occurs in EPA's analysis of the meat products industry. EPA's engineering model facilities do not distinguish beef processors from pork processors, or broiler processors from turkey processors. Rather the models distinguish only between red meat and poultry. Therefore, EPA first used its market model to calculate CPT individually for the beef, pork, broiler, and turkey meat types. EPA then constructed a CPT estimate for red meat as an average of beef CPT and pork CPT weighted by relative market quantities, and a similar weighted average for poultry

¹ Zero CPT can occur if market price does not increase at all in response to a decrease in supply. This could occur if demand is perfectly elastic (i.e., the demand curve in Figure E-1 is horizontal), or if supply is perfectly inelastic (i.e., the supply curve in Figure E-1 is vertical). Empirical studies show that neither is the case in markets for meat products (e.g., the price elasticity measures cited in Appendix D).

from the individual CPT measures for broilers and turkey. The CPT estimates used for this sensitivity analysis are:

- red meat — 43.5 percent
- poultry — 25.6 percent

Thus, EPA assumes for the purpose of this analysis that red meat processors will incur 56.5 percent and poultry processors will incur 74.4 percent of compliance costs.

Table E-1 presents the results of the CPT sensitivity analysis, and includes the results of the zero CPT analysis from Table 5-6.² EPA used upper-bound costs as the basis for this comparison. As would be expected, when compliance costs incurred by the facility are decreased by 25 to 45 percent, impacts are smaller. Under the proposed options (BAT 3 for all subcategories except J, for which BAT 2 has been proposed), the ratio of posttax annualized compliance costs to net income is:

• Subcategory A through D:	1.07 percent with CPT 1.90 percent with no CPT
• Subcategory E through I:	0.27 percent with CPT 0.40 percent with no CPT
• Subcategory J:	0.51 percent with CPT 0.68 percent with no CPT
• Subcategory K:	2.96 percent with CPT 3.98 percent with no CPT
• Subcategory L:	3.14 percent with CPT 4.23 percent with no CPT

The incremental probability of closure is also lower, resulting in smaller potential closure impacts. EPA projects that 0.5 (out of 209) facilities may close under the CPT scenario, compared to 0.8 facilities projected closures assuming zero CPT.

² EPA applied the smaller of the two CPT figures (poultry) to rendering as a more conservative assumption. To determine the CPT for mixed processors, EPA weighted the CPT of red meat and poultry by the relative production of each meat type by mixed processors (61 percent red meat, 39 percent poultry).

Table E-1
Sensitivity Analysis of Closure Impacts by Proposal Subcategory and Option
Cost Pass Through Analysis C Upper-Bound Costs

Option	Number of Facilities	Positive Cost Pass Through Analysis						Standard Analysis (Zero Cost Pass Through) ⁵					
		Annualized Compliance Costs per Facility ¹		Compliance Cost as a Percentage of Model Facility Net Income ²	Probability Cash Flow Less Than Compliance Costs ³	Projected Facility Impacts ⁴		Annualized Compliance Costs per Facility ¹		Compliance Cost as a Percentage of Model Facility Net Income ²	Probability Cash Flow Less Than Compliance Costs ³	Projected Facility Impacts ⁴	
		Pretax	Posttax			Closures	Employment	Pretax	Posttax			Closures	Employment
<i>Subcategory A through D</i>													
BAT1	66	\$0	\$0	0.00%	0.00%	0.0	0	\$0	\$0	0.00%	0.00%	0.0	0
BAT2		\$78,782	\$47,071	0.16%	0.03%	0.0	0	\$139,344	\$83,256	0.28%	0.05%	0.0	0
BAT3		\$472,096	\$311,084	1.07%	0.19%	0.1	159	\$835,010	\$550,223	1.90%	0.34%	0.2	318
BAT4		\$935,759	\$619,633	2.32%	0.42%	0.2	318	\$1,655,105	\$1,095,962	4.11%	0.74%	0.5	794
<i>Subcategory E through I</i>													
PSES1	60	\$61,514	\$40,476	0.32%	0.05%	0.0	0	\$108,802	\$71,591	0.57%	0.09%	0.0	0
PSES2		\$1,321,752	\$860,389	5.85%	0.97%	0.5	536	\$2,337,820	\$1,521,794	10.35%	1.73%	1.1	1,230
PSES3		\$839,776	\$555,630	4.07%	0.67%	0.3	304	\$1,485,337	\$982,758	7.21%	1.19%	0.6	609
PSES4		\$1,052,577	\$700,107	4.60%	0.76%	0.4	463	\$1,861,723	\$1,238,299	8.14%	1.36%	0.7	768
<i>Subcategory J</i>													
BAT1	19	\$0	\$0	0.00%	0.00%	0.0	0	\$0	\$0	0.00%	0.00%	0.0	0
BAT2		\$11,584	\$6,859	0.08%	0.01%	0.0	0	\$19,641	\$11,626	0.14%	0.02%	0.0	0
BAT3		\$21,955	\$14,255	0.27%	0.04%	0.0	0	\$33,648	\$21,782	0.40%	0.06%	0.0	0
BAT4		\$200,660	\$132,457	1.76%	0.28%	0.0	0	\$340,790	\$224,821	2.91%	0.46%	0.0	0
<i>Subcategory K</i>													
PSES1	234	\$44,509	\$28,504	0.49%	0.08%	0.2	45	\$74,306	\$47,519	0.80%	0.13%	0.3	91
PSES2		\$249,007	\$161,713	2.86%	0.45%	1.0	240	\$403,679	\$262,073	4.53%	0.72%	1.8	495
PSES3		\$201,477	\$132,421	2.31%	0.37%	0.8	211	\$330,879	\$217,257	3.72%	0.59%	1.3	346
PSES4		\$267,160	\$177,858	3.17%	0.50%	1.1	275	\$435,725	\$289,705	5.06%	0.81%	1.9	492
<i>Subcategory L</i>													
BAT1	21	\$0	\$0	0.00%	0.00%	0.0	0	\$0	\$0	0.00%	0.00%	0.0	0
BAT2		\$18,109	\$10,757	0.51%	0.09%	0.0	0	\$24,340	\$14,458	0.68%	0.12%	0.0	0

Table E-1 (cont.)
Sensitivity Analysis of Closure Impacts by Proposal Subcategory and Option
Cost Pass Through Analysis C Upper-Bound Costs

Option	Number of Facilities	Positive Cost Pass Through Analysis						Standard Analysis (Zero Cost Pass Through) ⁵					
		Annualized Compliance Costs per Facility ¹		Compliance Cost as a Percentage of Model Facility Net Income ²	Probability Cash Flow Less Than Compliance Costs ³	Projected Facility Impacts ⁴		Annualized Compliance Costs per Facility ¹		Compliance Cost as a Percentage of Model Facility Net Income ²	Probability Cash Flow Less Than Compliance Costs ³	Projected Facility Impacts ⁴	
		Pretax	Posttax			Closures	Employment	Pretax	Posttax			Closures	Employment
BAT3		\$190,375	\$125,683	5.98%	1.07%	0.3	14	\$255,876	\$168,926	8.03%	1.45%	0.3	14
BAT4		\$206,980	\$137,185	6.53%	1.18%	0.3	14	\$278,194	\$184,386	8.78%	1.59%	0.3	14
<i>Subcategory J</i>													
PSES1	75	\$12,206	\$7,760	0.37%	0.07%	0.0	0	\$16,406	\$10,429	0.50%	0.09%	0.0	0
PSES2		\$213,597	\$138,917	6.53%	1.17%	0.9	50	\$287,088	\$186,713	8.78%	1.58%	1.2	66
PSES3		\$256,373	\$169,907	8.03%	1.45%	1.1	62	\$344,581	\$228,365	10.79%	1.95%	1.5	81
PSES4		\$268,401	\$178,489	8.45%	1.52%	1.2	66	\$360,747	\$239,901	11.36%	2.06%	1.6	89
<i>Subcategory K</i>													
BAT1	88	\$0	\$0	0.00%	0.00%	0.0	0	\$0	\$0	0.00%	0.00%	0.0	0
BAT2		\$37,768	\$22,263	0.25%	0.05%	0.0	0	\$50,762	\$29,922	0.34%	0.06%	0.0	0
BAT3		\$378,672	\$249,421	2.96%	0.53%	0.3	190	\$508,959	\$335,237	3.98%	0.72%	0.5	265
BAT4		\$479,494	\$317,439	3.83%	0.69%	0.5	265	\$644,469	\$426,657	5.14%	0.93%	0.7	537
BAT5		\$517,412	\$343,949	4.18%	0.75%	0.5	265	\$695,432	\$462,287	5.61%	1.02%	0.9	591
<i>Subcategory L</i>													
PSES1	138	\$54,118	\$35,044	0.41%	0.07%	0.1	38	\$72,738	\$47,101	0.55%	0.10%	0.1	38
PSES2		\$943,262	\$613,490	6.48%	1.18%	1.6	1,269	\$1,267,800	\$824,567	8.71%	1.59%	2.1	1,653
PSES3		\$664,004	\$439,472	4.85%	1.12%	1.1	906	\$892,461	\$590,677	6.53%	1.51%	1.5	1,035
PSES4		\$681,618	\$452,488	5.06%	0.91%	1.1	906	\$916,136	\$608,171	6.80%	1.23%	1.7	1,208
<i>Subcategory L</i>													
BAT1	15	\$0	\$0	0.00%	0.00%	0.0	0	\$0	\$0	0.00%	0.00%	0.0	0
BAT2		\$13,760	\$8,253	0.28%	0.05%	0.0	0	\$18,678	\$11,203	0.39%	0.07%	0.0	0
BAT3		\$134,978	\$88,723	3.14%	0.57%	0.1	16	\$182,548	\$119,997	4.23%	0.77%	0.1	16
BAT4		\$196,996	\$130,496	4.46%	0.81%	0.1	16	\$267,851	\$177,456	6.04%	1.10%	0.1	16
BAT5	13 ⁶	\$204,211	\$135,746	4.99%	0.92%	0.1	16	\$274,471	\$182,451	6.71%	1.24%	0.1	16

Table E-1 (cont.)
Sensitivity Analysis of Closure Impacts by Proposal Subcategory and Option
Cost Pass Through Analysis C Upper-Bound Costs

Option	Number of Facilities	Positive Cost Pass Through Analysis						Standard Analysis (Zero Cost Pass Through) ⁵					
		Annualized Compliance Costs per Facility ¹		Compliance Cost as a Percentage of Model Facility Net Income ²	Probability Cash Flow Less Than Compliance Costs ³	Projected Facility Impacts ⁴		Annualized Compliance Costs per Facility ¹		Compliance Cost as a Percentage of Model Facility Net Income ²	Probability Cash Flow Less Than Compliance Costs ³	Projected Facility Impacts ⁴	
		Pretax	Posttax			Closures	Employment	Pretax	Posttax			Closures	Employment
PSES1	208	\$49,935	\$32,229	1.11%	0.20%	0.3	54	\$67,967	\$43,876	1.50%	0.27%	0.6	93
PSES2		\$343,866	\$223,013	7.09%	1.29%	2.7	478	\$469,256	\$304,357	9.63%	1.75%	3.6	751
PSES3		\$243,509	\$160,755	5.16%	0.93%	1.9	323	\$332,199	\$219,332	7.00%	1.27%	2.6	462
PSES4		\$306,668	\$204,587	6.59%	1.19%	2.5	446	\$419,271	\$279,769	8.96%	1.62%	3.3	583
<i>Total Excluding 65 Certainty Facilities</i>													
BAT1	209	\$0	\$0	NA	NA	0.0	0	\$0	\$0	NA	NA	0.0	0
BAT2		\$160,002	\$95,203	NA	NA	0.0	0	\$252,766	\$150,465	NA	NA	0.0	0
BAT3		\$1,198,077	\$789,166	NA	NA	0.8	379	\$1,816,041	\$1,196,164	NA	NA	1.1	613
BAT4		\$2,019,890	\$1,337,210	NA	NA	1.1	613	\$3,186,409	\$2,109,281	NA	NA	1.6	1,361
BAT5	101 ⁶	\$721,622	\$479,695	NA	NA	0.6	281	\$969,904	\$644,739	NA	NA	1.0	607
PSES1	715	\$222,283	\$144,013	NA	NA	0.6	137	\$340,219	\$220,517	NA	NA	1.0	222
PSES2		\$3,071,484	\$1,997,521	NA	NA	6.7	2,573	\$4,765,643	\$3,099,503	NA	NA	9.8	4,195
PSES3		\$2,205,139	\$1,458,185	NA	NA	5.2	1,806	\$3,385,456	\$2,238,389	NA	NA	7.5	2,533
PSES4		\$2,576,424	\$1,713,529	NA	NA	6.3	2,156	\$3,993,603	\$2,655,845	NA	NA	9.2	3,140

All impacts presented in this table are sum of the average of results for each subcategory, discharge type and model facility size combination, weighted by the number of facilities in each combination.

¹ Total annualized compliance costs for subcategory and discharge class divided by number of facilities in that class.

² Ratio of posttax annualized compliance costs to net income.

³ Probability net income or cash flow less than posttax annualized compliance costs minus probability net income or cash flow less than zero.

⁴ Closures: probability cash flow less than annualized compliance costs multiplied by the number of facilities in the subcategory. Employment: employees per model facility multiplied by the number of projected closures.

⁵ Standard Analysis Results are the same as those found in Chapter 5, Table 5-6.

⁶ Option BAT 5 is only found in Poultry operations.

E.2 BASELINE CLOSURES

As discussed in Appendix B, EPA used a Census special tabulation to calculate the variance of its model facility income measures. Combined with model facility mean income, and the assumption that income is normally distributed, these estimated variances result in a relatively high percentage of facilities earning negative income (about 25 to 35 percent based on cash flow, see Table B-7). Because negative cash flow implies that a facility is a baseline closure, EPA believes its methodology may result in an overestimate of variance. Therefore, EPA used an alternative method to estimate variance that would result in a smaller percentage of baseline closures, and compared projected impacts under the different estimates of variance. This sensitivity analysis is presented below.

EPA used the U.S. Small Business Administration's "births and deaths" database (U.S. SBA, 1998) to determine that over the 1995 to 1998 time frame firms have exited the meat products industry ("deaths") at a rate of 6.8 percent per year. Assuming the rate of firms exiting the market is equivalent to the percentage of baseline closures, EPA calculated the variance for the mean cash flow of each model facility class that would result in a 6.8 percent probability of negative cash flow (maintaining the assumption that cash flow is normally distributed).

Figure E-2 illustrates the method used to perform this sensitivity analysis. The curve marked "Census Variance" represents the cumulative distribution function of cash flow (with mean cash flow equal to \$100,000), where the variance is calculated from the Census special tabulation as described in Appendix B. This curve intercepts the vertical axis at about 28 percent; thus 28 percent of facilities in this group earn negative cash flow. The curve marked "SBA Variance" has identical mean and is also normally distributed, but the variance is estimated so that about 7 percent of facilities earn negative cash flow. EPA compared facility level impacts under the alternative estimates of variance using identical estimated average compliance costs.

Table E-2 presents the results of this sensitivity analysis. Per facility compliance costs and costs as a percent of model facility income are identical; the difference between the two methods occurs in the incremental probability of closure and the projected number of closures. The results display only minor variation in projected impacts between the alternative estimates; in some cases impacts are slightly higher,

Figure E-2
Alternative Distribution
Functions for Cash Flow

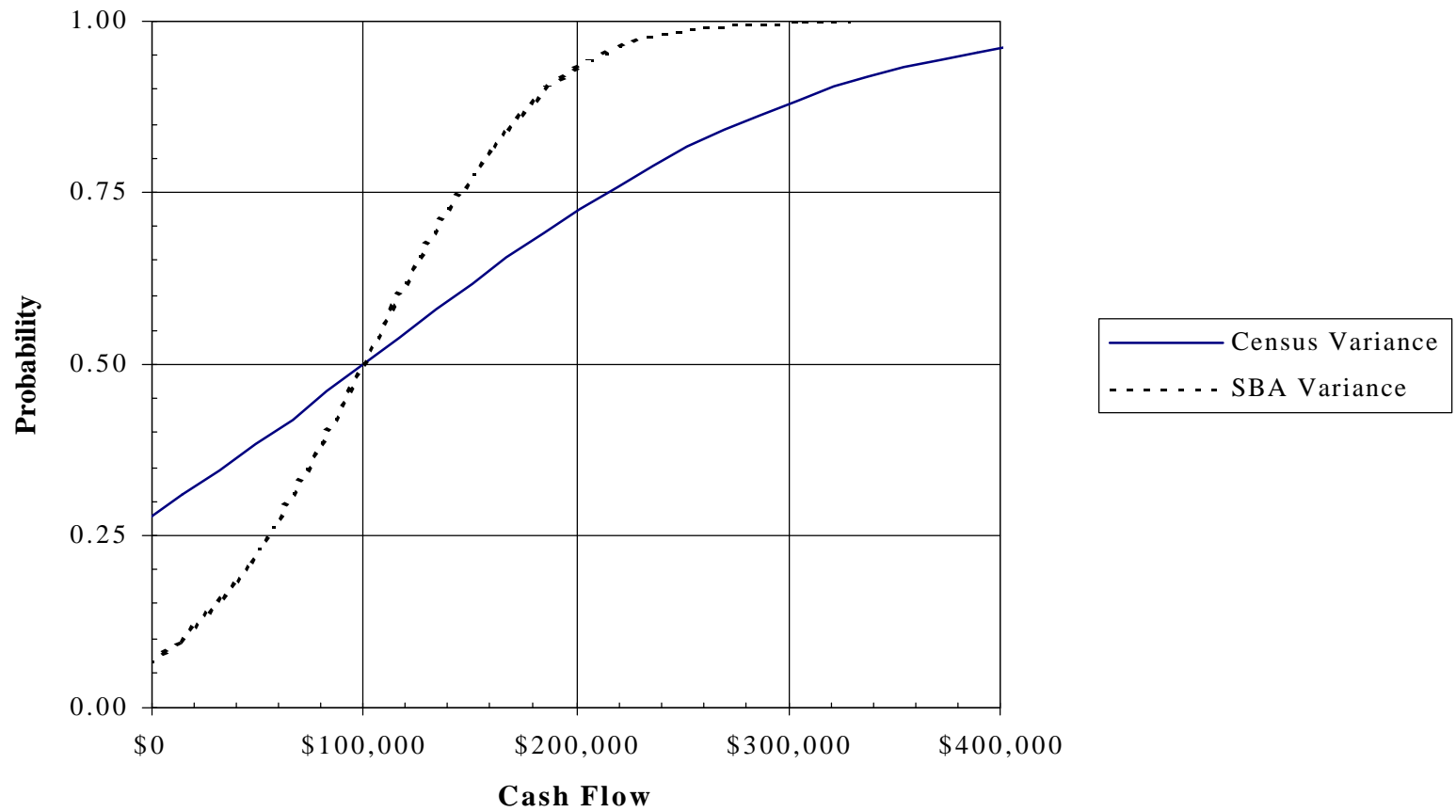

Table E-2
Sensitivity Analysis of Closure Impacts by Proposal Subcategory and Option
SBA Variance Compared to Census Variance C Upper-Bound Costs

Option	Number of Facilities	Annualized Compliance Costs per Facility ¹		Compliance Cost as a Percentage of Model Facility Net Income ²	SBA Variance			Standard Analysis (Census Variance) ⁵		
		Pretax	Posttax		Probability Cash Flow Less Than Compliance Costs ³	Projected Facility Impacts ⁴		Probability Cash Flow Less Than Compliance Costs ³	Projected Facility Impacts ⁴	
						Closures	Employment		Closures	Employment
<i>Subcategory A through D</i>										
BAT1	66	\$0	\$0	0.00%	0.00%	0.0	0	0.00%	0.0	0
BAT2		\$139,344	\$83,256	0.28%	0.05%	0.0	0	0.05%	0.0	0
BAT3		\$835,010	\$550,223	1.90%	0.34%	0.1	159	0.34%	0.2	318
BAT4		\$1,655,105	\$1,095,962	4.11%	0.73%	0.5	794	0.74%	0.5	794
<i>Subcategory E through I</i>										
PSES1	60	\$108,802	\$71,591	0.57%	0.09%	0.0	0	0.09%	0.0	0
PSES2		\$2,337,820	\$1,521,794	10.35%	1.76%	1.1	1,230	1.73%	1.1	1,230
PSES3		\$1,485,337	\$982,758	7.21%	1.18%	0.6	609	1.19%	0.6	609
PSES4		\$1,861,723	\$1,238,299	8.14%	1.35%	0.7	768	1.36%	0.7	768
<i>Subcategory J</i>										
BAT1	19	\$0	\$0	0.00%	0.00%	0.0	0	0.00%	0.0	0
BAT2		\$19,641	\$11,626	0.14%	0.02%	0.0	0	0.02%	0.0	0
BAT3		\$33,648	\$21,782	0.40%	0.07%	0.0	0	0.06%	0.0	0
BAT4		\$340,790	\$224,821	2.91%	0.49%	0.0	0	0.46%	0.0	0
<i>Subcategory K</i>										
PSES1	234	\$74,306	\$47,519	0.80%	0.13%	0.3	91	0.13%	0.3	91
PSES2		\$403,679	\$262,073	4.53%	0.78%	1.8	505	0.72%	1.8	495
PSES3		\$330,879	\$217,257	3.72%	0.63%	1.5	391	0.59%	1.3	346
PSES4		\$435,725	\$289,705	5.06%	0.87%	2.1	586	0.81%	1.9	492
<i>Subcategory L</i>										
BAT1	21	\$0	\$0	0.00%	0.00%	0.0	0	0.00%	0.0	0
BAT2		\$24,340	\$14,458	0.68%	0.11%	0.0	0	0.12%	0.0	0
BAT3		\$255,876	\$168,926	8.03%	1.38%	0.3	14	1.45%	0.3	14
BAT4		\$278,194	\$184,386	8.78%	1.52%	0.3	14	1.59%	0.3	14

Table E-2 (cont.)
Sensitivity Analysis of Closure Impacts by Proposal Subcategory and Option
SBA Variance Compared to Census Variance C Upper-Bound Costs

Option	Number of Facilities	Annualized Compliance Costs per Facility ¹		Compliance Cost as a Percentage of Model Facility Net Income ²	SBA Variance			Standard Analysis (Census Variance) ⁵		
		Pretax	Posttax		Probability Cash Flow Less Than Compliance Costs ³	Projected Facility Impacts ⁴		Probability Cash Flow Less Than Compliance Costs ³	Projected Facility Impacts ⁴	
						Closures	Employment		Closures	Employment
PSES1	75	\$16,406	\$10,429	0.50%	0.08%	0.0	0	0.09%	0.0	0
PSES2		\$287,088	\$186,713	8.78%	1.52%	1.1	62	1.58%	1.2	66
PSES3		\$344,581	\$228,365	10.79%	1.90%	1.4	78	1.95%	1.5	81
PSES4		\$360,747	\$239,901	11.36%	2.01%	1.5	81	2.06%	1.6	89
<i>Subcategory K</i>										
BAT1	88	\$0	\$0	0.00%	0.00%	0.0	0	0.00%	0.0	0
BAT2		\$50,762	\$29,922	0.34%	0.05%	0.0	0	0.06%	0.0	0
BAT3		\$508,959	\$335,237	3.98%	0.66%	0.4	227	0.72%	0.5	265
BAT4		\$644,469	\$426,657	5.14%	0.86%	0.6	401	0.93%	0.7	537
BAT5		\$695,432	\$462,287	5.61%	0.94%	0.8	553	1.02%	0.9	591
PSES1	138	\$72,738	\$47,101	0.55%	0.09%	0.1	38	0.10%	0.1	38
PSES2		\$1,267,800	\$824,567	8.71%	1.52%	2.0	1,616	1.59%	2.1	1,653
PSES3		\$892,461	\$590,677	6.53%	1.44%	1.4	997	1.51%	1.5	1,035
PSES4		\$916,136	\$608,171	6.80%	1.14%	1.4	997	1.23%	1.7	1,208
<i>Subcategory L</i>										
BAT1	15	\$0	\$0	0.00%	0.00%	0.0	0	0.00%	0.0	0
BAT2		\$18,678	\$11,203	0.39%	0.06%	0.0	0	0.07%	0.0	0
BAT3		\$182,548	\$119,997	4.23%	0.73%	0.1	16	0.77%	0.1	16
BAT4		\$267,851	\$177,456	6.04%	1.05%	0.1	16	1.10%	0.1	16
BAT5	13 ⁶	\$274,471	\$182,451	6.71%	1.18%	0.1	16	1.24%	0.1	16
PSES1	208	\$67,967	\$43,876	1.50%	0.25%	0.5	77	0.27%	0.6	93

**Table E-2 (cont.)
Sensitivity Analysis of Closure Impacts by Proposal Subcategory and Option
SBA Variance Compared to Census Variance C Upper-Bound Costs**

Option	Number of Facilities	Annualized Compliance Costs per Facility ¹		Compliance Cost as a Percentage of Model Facility Net Income ²	SBA Variance			Standard Analysis (Census Variance) ⁵		
		Pretax	Posttax		Probability Cash Flow Less Than Compliance Costs ³	Projected Facility Impacts ⁴		Probability Cash Flow Less Than Compliance Costs ³	Projected Facility Impacts ⁴	
						Closures	Employment		Closures	Employment
PSES2		\$469,256	\$304,357	9.63%	1.74%	3.6	741	1.75%	3.6	751
PSES3		\$332,199	\$219,332	7.00%	1.23%	2.6	468	1.27%	2.6	462
PSES4		\$419,271	\$279,769	8.96%	1.61%	3.3	580	1.62%	3.3	583
<i>Total Excluding 65 Certainty Facilities</i>										
BAT1	209	\$0	\$0	NA	NA	0.0	0	NA	0.0	0
BAT2		\$252,766	\$150,465	NA	NA	0.0	0	NA	0.0	0
BAT3		\$1,816,041	\$1,196,164	NA	NA	0.9	416	NA	1.1	613
BAT4		\$3,186,409	\$2,109,281	NA	NA	1.5	1,225	NA	1.6	1,361
BAT5	101 ⁶	\$969,904	\$644,739	NA	NA	0.9	569	NA	1.0	607
PSES1	715	\$340,219	\$220,517	NA	NA	0.9	206	NA	1.0	222
PSES2		\$4,765,643	\$3,099,503	NA	NA	9.6	4,154	NA	9.8	4,195
PSES3		\$3,385,456	\$2,238,389	NA	NA	7.5	2,543	NA	7.5	2,533
PSES4		\$3,993,603	\$2,655,845	NA	NA	9.0	3,012	NA	9.2	3,140

All impacts presented in this table are sum of the average of results for each subcategory, discharge type and model facility size combination, weighted by the number of facilities in each combination.

¹ Total annualized compliance costs for subcategory and discharge class divided by number of facilities in that class.

² Ratio of posttax annualized compliance costs to net income.

³ Probability net income or cash flow less than posttax annualized compliance costs minus probability net income or cash flow less than zero.

⁴ Closures: probability cash flow less than annualized compliance costs multiplied by the number of facilities in the subcategory. Employment: employees per model facility multiplied by the number of projected closures.

⁵ Standard Analysis Results are the same as those found in Chapter 5, Table 5-6.

⁶ Option BAT 5 is only found in Poultry operations.

in others impacts are slightly lower using the “SBA Variance” rather than the “Census Variance.” For example, under PSES 2 for Subcategory A through D, the incremental probability of closure is slightly larger for the model using the SBA variance (1.76 percent) compared to the model using the Census variance (1.73 percent). However, under PSES 3, the incremental probability of closure is slightly smaller using the SBA variance (1.18 percent compared to 1.19 percent). Intuitively, this suggests that within the range of estimated compliance costs per facility relevant to this proposal, the slopes of the two cumulative distribution functions are approximately equal. This result cannot be generalized however to different ranges of compliance costs or baseline closures.

E.3 DISTRIBUTIONAL ASSUMPTIONS

As discussed in Appendix B, EPA assumed in its analyses that model facility income measures are normally distributed. However, there is reason to suspect, especially for revenues, that the distribution of income for each model facility class may be skewed. That is, more than 50 percent of facilities in a class earn less than the average class income, and less than 50 percent of facilities earn more than the average income. EPA performed two sensitivity analyses, one based on revenues, the other based on cash flow, to examine the significance of the distributional assumption for the determination of impacts.

EPA selected the lognormal distribution to use as the alternative to the normal distribution for the purpose of this sensitivity analysis. EPA used the same model facility mean income and variance that it estimated for the normal distribution in each model class, and applied the following transformation to determine mean and variance for the lognormal distribution:

$$\mu_{\ln x} = \ln \mu_x - \frac{1}{2} \sigma_{\ln x}^2$$

$$\sigma_{\ln x}^2 = \sqrt{\ln \left(1 + \frac{\sigma_x^2}{\mu_x} \right)}$$

where (μ_x, σ_x^2) are the mean and variance for the normal distribution, and $(\mu_{\ln x}, \sigma_{\ln x}^2)$ are the transformed mean and variance for the lognormal distribution. Thus, EPA uses equivalent means and variances for the two distributions.

Figure E-3 illustrates the alternative distribution assumptions for average model facility revenues of \$1 million using the normal and lognormal cumulative distribution functions. The normal distribution shows about 7 percent of facilities earning revenues less than \$0, which is consistent with the variance for revenues provided by Census to EPA. The skewness of the lognormal distribution can be observed by the fact that about 68 percent of establishments earn less than the mean revenues of \$1 million under the lognormal distribution, compared to 50 percent under the normal distribution.

Section E.3.1 presents the results of the sensitivity analysis of the projected number of facilities incurring compliance costs exceeding specified percentages of revenues (the “sales test”) under the alternative distributional assumptions. Section E.3.2 performs an analysis of closure impacts under the two different distributions.

E.3.1 Sales Test Impacts Under Alternative Distribution Assumptions

Table E-3 presents the results for the sensitivity analysis of sales test impacts under the normal and lognormal distribution assumptions (see Section 6.4.3 for further discussion of the sales test). In general — but not invariably — the sales test impacts are larger under the assumption that revenues are lognormally distributed rather than normally distributed. Under the proposed options (BAT 3 for all subcategories except J, for which BAT 2 is proposed), EPA projects that 19.4 facilities (of 209) would incur compliance costs exceeding one percent of revenues based on the lognormal distribution, while 17.9 facilities would exceed that threshold using the normal distribution.

Note that in Figure E-3, the lognormal distribution shows no facilities earning negative revenues (i.e., one cannot take the natural log of a negative number). While intuitively this seems an improvement over the normal distribution, which suggests 7 percent of facilities earn negative revenues, this result may not be entirely reflective of reality either. With the exception of cost centers, it is unlikely a facility would

Figure E-3
Alternative Assumptions for
Baseline Distribution Function
Revenues

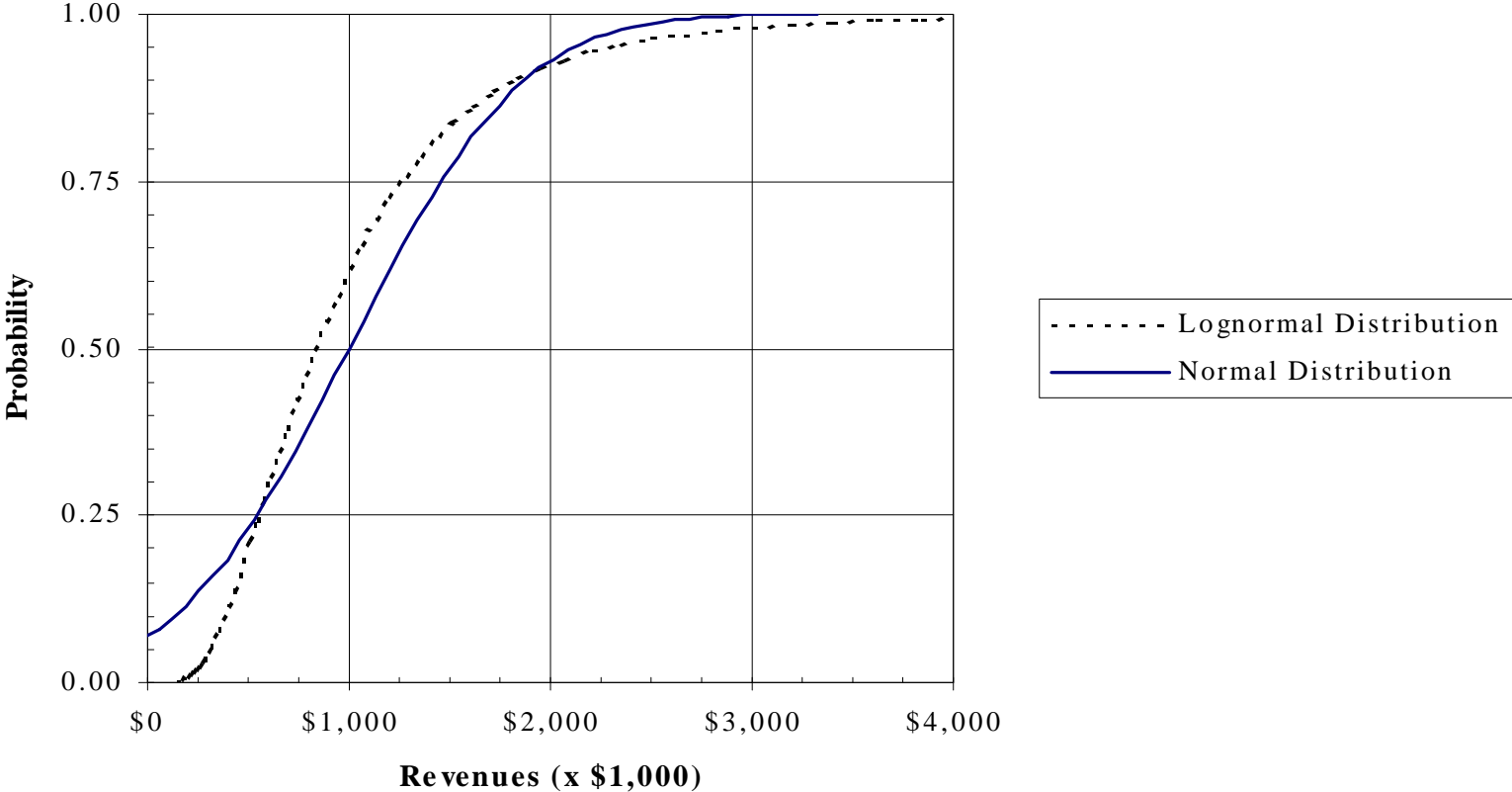

Table E-3
Sensitivity Analysis of Nonclosure Impacts by Proposal Subcategory and Option
Lognormal Distribution Compared to Normal Distribution C Upper-Bound Costs

Option	Number of Facilities	Compliance Cost as a Percentage of Model Facility Revenues ¹	Lognormal Distribution			Normal Distribution		
			Facilities Incurring Compliance Costs Greater Than % of Revenues ²			Facilities Incurring Compliance Costs Greater Than % of Revenues ²		
			1 Percent	3 Percent	5 Percent	1 Percent	3 Percent	5 Percent
<i>Subcategory A through D</i>								
BAT1	66	0.00%	0.0	0.0	0.0	0.0	0.0	0.0
BAT2		0.02%	0.0	0.0	0.0	0.2	0.0	0.0
BAT3		0.12%	1.5	0.0	0.0	2.1	0.6	0.3
BAT4		0.27%	3.3	0.0	0.0	4.8	1.3	0.7
PSES1	60	0.02%	0.0	0.0	0.0	0.1	0.0	0.0
PSES2		0.46%	9.6	0.7	0.1	9.1	2.1	1.3
PSES3		0.30%	3.9	0.1	0.0	5.0	1.4	0.8
PSES4		0.36%	6.0	0.1	0.0	6.3	1.7	0.9
<i>Subcategory E through I</i>								
BAT1	19	0.00%	0.0	0.0	0.0	0.0	0.0	0.0
BAT2		0.02%	0.0	0.0	0.0	0.1	0.0	0.0
BAT3		0.05%	0.3	0.0	0.0	0.2	0.1	0.1
BAT4		0.33%	3.0	0.3	0.1	1.7	0.5	0.3
PSES1	234	0.09%	1.3	0.0	0.0	5.1	1.6	0.9
PSES2		0.52%	64.3	14.3	4.8	40.8	11.2	6.4
PSES3		0.41%	50.8	7.1	1.8	30.1	8.5	4.9
PSES4		0.55%	71.8	14.6	4.8	43.4	11.9	6.8
<i>Subcategory J</i>								
BAT1	21	0.00%	0.0	0.0	0.0	0.0	0.0	0.0
BAT2		0.17%	2.3	0.2	0.0	0.9	0.3	0.2
BAT3		1.85%	18.2	10.8	6.7	10.7	3.3	1.8
BAT4		2.02%	18.5	11.5	7.3	11.4	3.7	2.1
PSES1	75	0.12%	4.3	0.3	0.0	2.2	0.6	0.3
PSES2		2.04%	65.8	40.6	26.3	40.7	13.4	7.6
PSES3		2.47%	68.5	46.3	31.6	46.9	16.5	9.4
PSES4		2.60%	69.1	47.7	33.2	48.4	17.4	9.9
<i>Subcategory K</i>								
BAT1	88	0.00%	0.0	0.0	0.0	0.0	0.0	0.0
BAT2		0.04%	0.0	0.0	0.0	0.6	0.0	0.0
BAT3		0.43%	12.2	0.4	0.0	12.2	2.8	1.4
BAT4		0.54%	19.5	1.0	0.1	16.9	3.6	1.8
BAT5		0.59%	22.5	1.4	0.2	19.2	4.2	2.2

Table E-3 (cont.)
Sensitivity Analysis of Nonclosure Impacts by Proposal Subcategory and Option
Lognormal Distribution Compared to Normal Distribution — Upper-Bound Costs

Option	Number of Facilities	Compliance Cost as a Percentage of Model Facility Revenues ¹	Lognormal Distribution			Normal Distribution		
			Facilities Incurring Compliance Costs Greater Than % of Revenues ²			Facilities Incurring Compliance Costs Greater Than % of Revenues ²		
			1 Percent	3 Percent	5 Percent	1 Percent	3 Percent	5 Percent
PSES1	138	0.06%	0.0	0.0	0.0	1.3	0.4	0.2
PSES2		0.94%	61.2	10.5	3.2	50.0	12.7	6.5
PSES3		0.67%	43.5	3.3	0.5	35.6	7.5	3.9
PSES4		0.70%	45.9	3.4	0.6	37.3	7.8	4.1
<i>Subcategory L</i>								
BAT1	15	0.00%	0.0	0.0	0.0	0.0	0.0	0.0
BAT2		0.05%	0.0	0.0	0.0	0.1	0.0	0.0
BAT3		0.48%	3.1	0.1	0.0	2.5	0.4	0.2
BAT4		0.69%	6.0	0.4	0.0	4.0	0.8	0.4
BAT5	13 ³	0.75%	5.6	0.3	0.0	4.0	0.8	0.4
<i>Total Excluding 65 Certainty Facilities</i>								
PSES1	208	0.18%	2.0	0.0	0.0	8.8	2.4	1.4
PSES2		1.15%	138.9	25.5	5.7	110.1	23.2	11.7
PSES3		0.82%	102.7	9.7	1.7	70.9	14.7	7.7
PSES4		1.05%	128.5	20.4	4.6	97.4	20.3	10.4
BAT1	209	NA	0	0	0	0	0	0
BAT2		NA	2	0	0	2	0	0
BAT3		NA	35	11	7	28	7	4
BAT4		NA	50	13	8	39	10	5
BAT5	101 ³	NA	28	2	0	23	5	3
PSES1	715	NA	8	0	0	18	5	3
PSES2		NA	340	92	40	251	63	34
PSES3		NA	269	66	36	188	49	27
PSES4		NA	321	86	43	233	59	32

Compliance costs as a percent of facility income results are presented as the average for each subcategory, discharge type and model facility size combination, weighted by the number of facilities in each combination.

Number of facilities incurring those impacts is the sum over all facility sizes by subcategory and discharge type.

¹ Ratio of pretax annualized compliance cost to revenues; ratio of posttax annualized compliance costs to cash flow.

² Probability compliance costs exceed specified percentage of income measure multiplied by the number of facilities in the subcategory size class.

³ Option BAT 5 is only found in Poultry operations.

earn zero revenues, just as it is unlikely that facilities earn negative revenues. Any non-cost center with positive production and sales would presumably earn at least some minimal level of revenues, otherwise it would not be in business. However, there is no information available on which to set a benchmark for minimum revenues in a model facility class.

E.3.2 Closure Impacts Under Alternative Distribution Assumptions

EPA performed a similar sensitivity analysis comparing closure impacts under alternative distribution assumptions. One complexity of using the lognormal distribution in the context of the closure model is that the lognormal distribution cannot be used with negative values of cash flow. However, unlike the revenue model used above (where negative revenues do not make analytic sense), negative cash flow is not only logically possible in this context, it is probable.

Figure E-4 illustrates how EPA incorporated negative cash flow into the lognormal model for the evaluation of potential closure impacts. EPA used the percentage of baseline closures under the normal distribution as a benchmark. Then EPA calculated the level of cash flow resulting in the same probability using the lognormal distribution, and took that as the baseline from which impacts are measured. Intuitively, the effect is to shift the lognormal distribution to the left, truncating it at the same probability of zero cash flow derived from the normal distribution. This is illustrated in Figure E-4. Note that this method probably overestimates the necessary adjustment to the lognormal distribution. The reason EPA suspects the distribution of cash flow may be skewed in a model class is precisely because of the high percentage of baseline closures under the normal distribution. However, for the purpose of this sensitivity analysis, this adjustment is acceptable.

Table E-4 presents projected closure impacts under the alternative assumptions concerning the distribution of cash flow. As would be anticipated, given the illustration in Figure E-4, projected incremental closures are higher under the lognormal distribution than under the normal distribution. Under the proposed options (BAT 3 for all subcategories except J, for which BAT 2 is proposed), EPA projects that 4.9 facilities (of 209) would incur compliance costs exceeding cash flow under the lognormal distribution, compared to 0.7 facilities exceeding that threshold under the normal distribution.

Figure E-4
Alternative Assumptions for
Baseline Distribution Function
Cash Flow

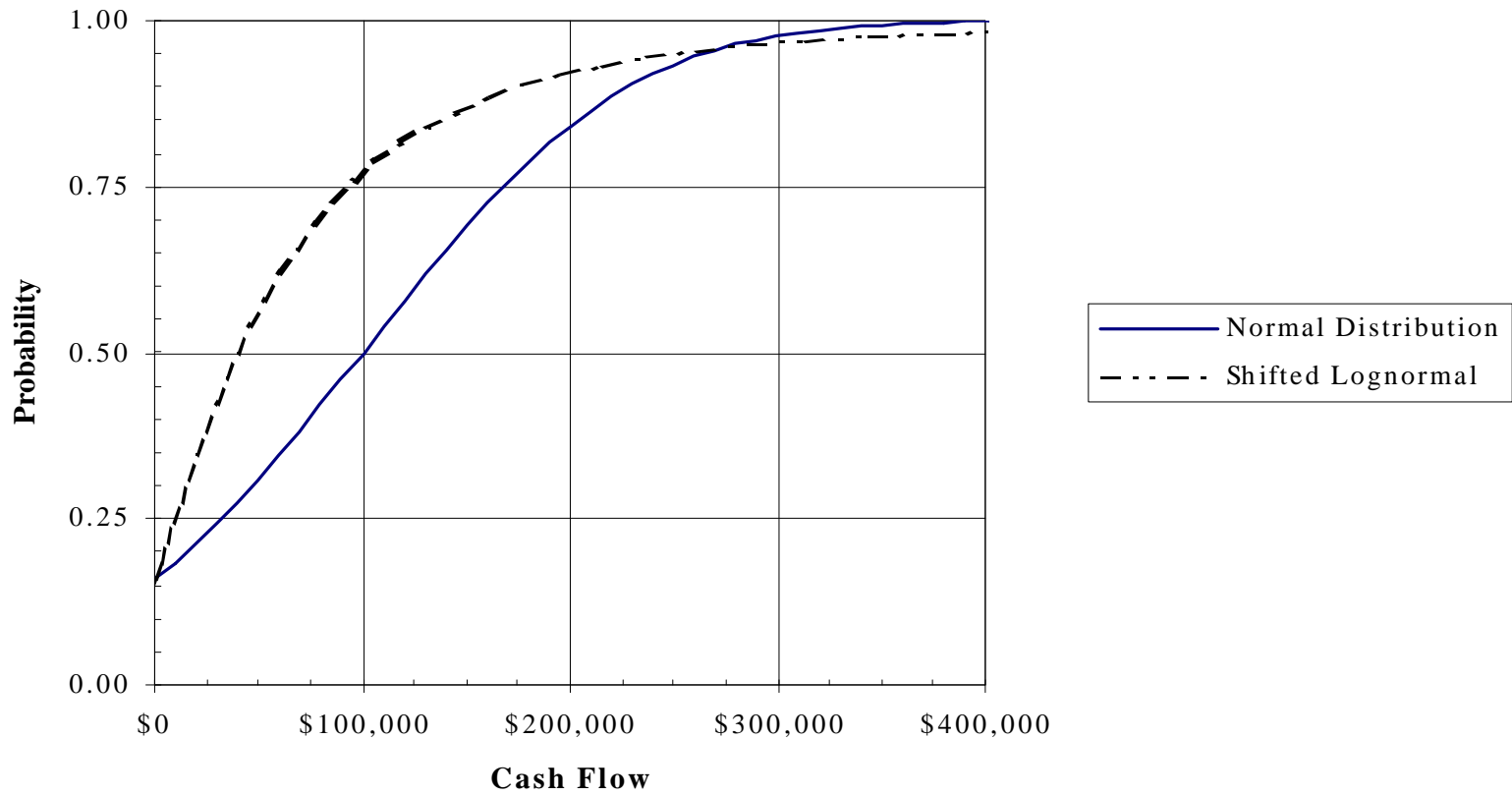

Table E-4
Sensitivity Analysis of Closure Impacts by Proposal Subcategory and Option
Lognormal Distribution Analysis Compared to Normal Distribution Analysis C Upper-Bound Costs

Option	Number of Facilities	Annualized Compliance Costs per Facility ¹		Compliance Cost as a Percentage of Model Facility ²		Lognormal Distribution Analysis			Standard Analysis (Normal Distribution) ⁵		
						Probability Cash Flow Less Than Compliance Costs ³	Lognormal Projected Facility Impacts ⁴		Probability Cash Flow Less Than Compliance Costs ³	Projected Facility Impacts ⁴	
		Pretax	Posttax	Net Income	Cash Flow		Closures	Employment		Closures	Employment
<i>Subcategory A through D</i>											
BAT1	66	\$0	\$0	0.00%	0.00%	0.00%	0.0	0	0.00%	0.0	0
BAT2		\$139,344	\$83,256	0.28%	0.25%	0.28%	0.1	159	0.05%	0.0	0
BAT3		\$835,010	\$550,223	1.90%	1.66%	1.78%	1.2	1,903	0.34%	0.2	318
BAT4		\$1,655,105	\$1,095,962	4.11%	3.58%	3.83%	2.5	3,677	0.74%	0.5	794
<i>Subcategory E through I</i>											
PSES1	60	\$108,802	\$71,591	0.57%	0.44%	0.48%	0.2	145	0.09%	0.0	0
PSES2		\$2,337,820	\$1,521,794	10.35%	8.09%	8.24%	5.0	5,610	1.73%	1.1	1,230
PSES3		\$1,485,337	\$982,758	7.21%	5.59%	5.83%	3.5	3,747	1.19%	0.6	609
PSES4		\$1,861,723	\$1,238,299	8.14%	6.39%	6.65%	4.0	4,540	1.36%	0.7	768
<i>Subcategory J</i>											
BAT1	19	\$0	\$0	0.00%	0.00%	0.00%	0.0	0	0.00%	0.0	0
BAT2		\$19,641	\$11,626	0.14%	0.12%	0.13%	0.0	0	0.02%	0.0	0
BAT3		\$33,648	\$21,782	0.40%	0.33%	0.38%	0.1	10	0.06%	0.0	0
BAT4		\$340,790	\$224,821	2.91%	2.44%	2.70%	0.5	175	0.46%	0.0	0
<i>Subcategory K</i>											
PSES1	234	\$74,306	\$47,519	0.80%	0.67%	0.76%	1.7	487	0.13%	0.3	91
PSES2		\$403,679	\$262,073	4.53%	3.77%	4.07%	9.4	2,602	0.72%	1.8	495
PSES3		\$330,879	\$217,257	3.72%	3.09%	3.39%	7.9	2,249	0.59%	1.3	346
PSES4		\$435,725	\$289,705	5.06%	4.21%	4.54%	10.5	2,911	0.81%	1.9	492
<i>Subcategory L</i>											
BAT1	21	\$0	\$0	0.00%	0.00%	0.00%	0.0	0	0.00%	0.0	0
BAT2		\$24,340	\$14,458	0.68%	0.56%	0.60%	0.1	8	0.12%	0.0	0
BAT3		\$255,876	\$168,926	8.03%	6.55%	6.77%	1.4	78	1.45%	0.3	14
BAT4		\$278,194	\$184,386	8.78%	7.16%	7.37%	1.5	81	1.59%	0.3	14

Table E-4 (cont.)
Sensitivity Analysis of Closure Impacts by Proposal Subcategory and Option
Lognormal Distribution Analysis Compared to Normal Distribution Analysis C Upper-Bound Costs

Option	Number of Facilities	Annualized Compliance Costs per Facility ¹		Compliance Cost as a Percentage of Model Facility ²		Lognormal Distribution Analysis			Standard Analysis (Normal Distribution)		
						Probability Cash Flow Less Than Compliance Costs ³	Lognormal Projected Facility Impacts ⁴		Probability Cash Flow Less Than Compliance Costs ³	Projected Facility Impacts ⁴	
		Pretax	Posttax	Net Income	Cash Flow		Closures	Employment		Closures	Employment
PSES1	75	\$16,406	\$10,429	0.50%	0.41%	0.44%	0.3	14	0.09%	0.0	0
PSES2		\$287,088	\$186,713	8.78%	7.13%	7.32%	5.5	312	1.58%	1.2	66
PSES3		\$344,581	\$228,365	10.79%	8.78%	8.91%	6.8	376	1.95%	1.5	81
PSES4		\$360,747	\$239,901	11.36%	9.25%	9.36%	7.1	392	2.06%	1.6	89
<i>Subcategory K</i>											
BAT1	88	\$0	\$0	0.00%	0.00%	0.00%	0.0	0	0.00%	0.0	0
BAT2		\$50,762	\$29,922	0.34%	0.27%	0.29%	0.1	38	0.06%	0.0	0
BAT3		\$508,959	\$335,237	3.98%	3.20%	3.34%	2.9	2,261	0.72%	0.5	265
BAT4		\$644,469	\$426,657	5.14%	4.13%	4.27%	3.9	2,890	0.93%	0.7	537
BAT5		\$695,432	\$462,287	5.61%	4.50%	4.65%	4.3	3,236	1.02%	0.9	591
PSES1	138	\$72,738	\$47,101	0.55%	0.43%	0.46%	0.5	385	0.10%	0.1	38
PSES2		\$1,267,800	\$824,567	8.71%	6.95%	6.97%	9.6	8,046	1.59%	2.1	1,653
PSES3		\$892,461	\$590,677	6.53%	5.18%	6.66%	7.4	5,963	1.51%	1.5	1,035
PSES4		\$916,136	\$608,171	6.80%	5.40%	5.52%	7.7	6,174	1.23%	1.7	1,208
<i>Subcategory L</i>											
BAT1	15	\$0	\$0	0.00%	0.00%	0.00%	0.0	0	0.00%	0.0	0
BAT2		\$18,678	\$11,203	0.39%	0.32%	0.35%	0.0	0	0.07%	0.0	0
BAT3		\$182,548	\$119,997	4.23%	3.54%	3.73%	0.6	124	0.77%	0.1	16
BAT4		\$267,851	\$177,456	6.04%	5.04%	5.27%	0.8	153	1.10%	0.1	16
BAT5	13 ⁶	\$274,471	\$182,451	6.71%	5.61%	5.80%	0.8	151	1.24%	0.1	16
PSES1	208	\$67,967	\$43,876	1.50%	1.26%	1.36%	2.8	472	0.27%	0.6	93
PSES2		\$469,256	\$304,357	9.63%	8.06%	8.22%	17.1	3,543	1.75%	3.6	751

Table E-4 (cont.)
Sensitivity Analysis of Closure Impacts by Proposal Subcategory and Option
Lognormal Distribution Analysis Compared to Normal Distribution Analysis C Upper-Bound Costs

Option	Number of Facilities	Annualized Compliance Costs per Facility ¹		Compliance Cost as a Percentage of Model Facility ²		Lognormal Distribution Analysis			Standard Analysis (Normal Distribution) ⁵		
						Probability Cash Flow Less Than Compliance Costs ³	Lognormal Projected Facility Impacts ⁴		Probability Cash Flow Less Than Compliance Costs ³	Projected Facility Impacts ⁴	
							Closures	Employment		Closures	Employment
PSES3		\$332,199	\$219,332	7.00%	5.87%	6.10%	12.6	2,548	1.27%	2.6	462
PSES4		\$419,271	\$279,769	8.96%	7.51%	7.70%	16.0	3,229	1.62%	3.3	583
<i>Total Excluding 65 Certainty Facilities</i>											
BAT1	209	\$0	\$0	NA	NA	NA	0.0	0	NA	0.0	0
BAT2		\$252,766	\$150,465	NA	NA	NA	0.3	205	NA	0.0	0
BAT3		\$1,816,041	\$1,196,164	NA	NA	NA	6.2	4,376	NA	1.1	613
BAT4		\$3,186,409	\$2,109,281	NA	NA	NA	9.2	6,976	NA	1.6	1,361
BAT5	101 ⁶	\$969,904	\$644,739	NA	NA	NA	5.1	3,387	NA	1.0	607
PSES1	715	\$340,219	\$220,517	NA	NA	NA	5.5	1,503	NA	1.0	222
PSES2		\$4,765,643	\$3,099,503	NA	NA	NA	46.6	20,113	NA	9.8	4,195
PSES3		\$3,385,456	\$2,238,389	NA	NA	NA	38.2	14,883	NA	7.5	2,533
PSES4		\$3,993,603	\$2,655,845	NA	NA	NA	45.3	17,246	NA	9.2	3,140

All impacts presented in this table are sum of the average of results for each subcategory, discharge type and model facility size combination, weighted by the number of facilities in each combination.

¹ Total annualized compliance costs for subcategory and discharge class divided by number of facilities in that class.

² Ratio of posttax annualized compliance costs to net income.

³ Probability net income or cash flow less than posttax annualized compliance costs minus probability net income or cash flow less than zero.

⁴ Closures: probability cash flow less than annualized compliance costs multiplied by the number of facilities in the subcategory. Employment: employees per model facility multiplied by the number of projected closures.

⁵ Standard Analysis Results are the same as those found in Chapter 5, Table 5-6.

⁶ Option BAT 5 is only found in Poultry operations.

E.4 REFERENCES

U.S. SBA. 1998. Statistics of U.S. Businesses: Firm Size Data: Dynamic Data: Download U.S. industry group data, 1990-1998 one year changes and 1990-1995 (U.S. Births, deaths, and job creation by U.S. industry group, 1990 - 1998.) U.S. Small Business Administration, Office of Advocacy. Available at: <http://www.sba.gov/advo/stats/data.html>.

APPENDIX F

COST EFFECTIVENESS ANALYSIS

F.1 INTRODUCTION

As part of the process of setting effluent limitations guidelines and developing standards, EPA uses cost effectiveness calculations to compare the efficiencies of regulatory options for removing priority and nonconventional pollutants.¹ This cost effectiveness (CE) analysis presents an evaluation of the technical efficiency of pollutant control options for the proposed effluent limitations guidelines and standards for the meat products industry based on Best Available Technology Economically Achievable (BAT) and Pretreatment Standards for Existing Sources (PSES). BAT standards set effluent limitations on toxic pollutants and nutrients for direct dischargers prior to wastewater discharge directly into a water body such as a stream, river, lake, estuary, or ocean. Indirect dischargers send wastewater to publicly owned treatment works (POTW) for further treatment prior to discharge to U.S. surface waters; PSES standards set limitations for indirect dischargers on toxic pollutants and nutrients which pass through a POTW.

The analyses presented in this section include a standard cost effectiveness analysis, based on the approach EPA has historically used for developing an effluent guideline for toxic pollutants, an analysis of the cost reasonableness of nonconventional pollutant removals, and an analysis of the cost effectiveness of removing nutrients. This expanded approach is necessary to evaluate the broad range of pollutants in meat slaughtering and processing wastewater, for which nutrients, conventional pollutants, and nonconventional pollutants may be more significant than toxic pollutants. EPA's standard CE analysis is used for analyzing the removal of toxic pollutants. EPA's standard CE analysis does not adequately address removals of nutrients, total suspended solids, and pathogens. To account for the estimated removals of nutrients under the proposed meat products regulation in the analysis, the Agency has developed an alternative approach to

¹ A list of priority ("toxic") and conventional pollutants are defined in 40 CFR Part 401. There are more than 120 priority pollutants, including metals, pesticides, and organic and inorganic compounds. Conventional pollutants include biological oxygen demand (BOD), total suspended solids (TSS), pH, fecal coliform, and oil and grease. Nonconventional pollutants comprise all other pollutants, including nutrients (i.e., they do not include conventional and priority pollutants).

evaluate the pollutant removal effectiveness of nutrients relative to cost. Although pathogens maybe an important constituent of meat processing wastewater, EPA has not at this time developed an approach that would allow a similar assessment of pathogen removals.

The organization of this chapter is as follows. Section F.2 discusses EPA's standard cost effectiveness methodology and presents the results of this analysis; this section also identifies the pollutants included in the analysis, presents EPA's toxic weighting factors for each pollutant, and discusses POTW removal factors for indirect dischargers. Section F.3 explains the cost reasonableness analysis and presents the results of this analysis. Section F.4 discusses EPA's cost effectiveness methodology for nutrients and contains the results of the nutrients cost effectiveness analysis. Section F.5 contains supplementary data tables, while Section F.6 lists references.

F.2 COST EFFECTIVENESS METHODOLOGY AND RESULTS: TOXIC POLLUTANTS

F.2.1 Overview

Cost effectiveness is evaluated as the incremental annualized cost of a pollution control option in an industry or industry subcategory per incremental pound equivalent of pollutant (i.e., pound of pollutant adjusted for toxicity) removed by that control option. EPA uses the cost effectiveness analysis primarily to compare the removal efficiencies of regulatory options under consideration for a rule. A secondary and less effective use is to compare the cost effectiveness of the proposed options for the meat products industry to those for effluent limitation guidelines and standards for other industries.

To develop a cost effectiveness study, the following steps must be taken to define the analysis or generate data used for calculating values:

- Determine the pollutants effectively removed from the wastewater.
- For each pollutant, identify the toxic weights and POTW removal factors. (The first adjusts the removals to reflect the relative toxicity of the pollutants while the second reflects the ability of a POTW or sewage treatment plant to remove pollutants prior to discharge to the water. These are described in Sections F.2.2 and F.2.3.)

- Define the regulatory pollution control options.
- Calculate pollutant removals for each pollution control option.
- Calculate the product of the pollutant removed (in pounds), the toxic weighting factor, and the POTW removal factor. The resultant removal is specified in terms of “pounds equivalent” removed.
- Determine the annualized cost of each pollution control option.
- Calculate incremental CE for options.

Table F-1 presents the pollutants, their toxic weights, and POTW efficiency and removal factors used in the CE calculations for toxic pollutants as well as conventional and nonconventional pollutants.

F.2.2 Toxic Weighting Factors

Cost effectiveness analyses account for differences in toxicity among the pollutants using toxic weighting factors. Accounting for these differences is necessary because the potentially harmful effects on human and aquatic life are specific to the pollutant. For example, a pound of zinc in an effluent stream has a significantly different, less harmful effect than a pound of PCBs. Toxic weighting factors for pollutants are derived using ambient water quality criteria and toxicity values. For most industries, toxic weighting factors are developed from chronic freshwater aquatic criteria. In cases where a human health criterion has also been established for the consumption of fish, the sum of both the human and aquatic criteria are used to derive toxic weighting factors. The factors are standardized by relating them to a “benchmark” toxicity value, which was based on the toxicity of copper when the methodology was developed.²

Examples of the effects of different aquatic and human health criteria on freshwater toxic weighting factors are presented in Table F-2. As shown in this table, the toxic weighting factor is the sum of two criteria-weighted ratios: the former benchmark copper criterion divided by the human health

² Although the water quality criterion has been revised (to 9.0 µg/l), all cost effectiveness analyses for effluent guideline regulations continue to use the former criterion of 5.6 µg/l as a benchmark so that cost effectiveness values can continue to be compared to those for other effluent guidelines. Where copper is present in the effluent, the revised higher criterion for copper results in a toxic weighting factor for copper of 0.63 rather than 1.0.

**Table F-1
Toxic Weighting Factors and POTW Efficiency and Removal Factors for
Meat Products Industry Pollutants of Concern**

POLLUTANT	Toxic Weighting Factor	POTW Efficiency Factor	POTW Removal Factor
TOXICS			
Ammonia as Nitrogen	1.8e-03	38.9%	6.1e-01
Barium	2.0e-03	16.0%	8.4e-01
Carbaryl	2.8e+02	30.0%	7.0e-01
Chromium	7.6e-02	80.3%	2.0e-01
Cis-permethrin	4.5e+00	50.0%	5.0e-01
Copper	6.3e-01	84.2%	1.6e-01
Manganese	7.0e-02	35.5%	6.4e-01
Molybdenum	2.0e-01	18.9%	8.1e-01
Nickel	1.1e-01	51.4%	4.9e-01
Nitrate/Nitrite	6.2e-05	90.0%	1.0e-01
Titanium	2.9e-02	91.8%	8.2e-02
Trans-permethrin	4.5e+00	50.0%	5.0e-01
Vanadium	6.2e-01	9.5%	9.0e-01
Zinc	4.7e-02	79.1%	2.1e-01
NUTRIENTS			
Total Phosphorus	NA	57.4%	4.3e-01
Total Nitrogen	NA	UNK	UNK
Total Kjeldahl Nitrogen (TKN) ¹	NA	57.4%	4.3e-01
CONVENTIONALS			
5-Day Biochemical Oxygen Demand (BOD)	NA	89.1%	1.1e-01
Hexane Extractable Material (HEM)	NA	86.1%	1.4e-01
Total Suspended Solids (TSS)	NA	89.6%	1.0e-01
NONCONVENTIONALS			
Chemical Oxygen Demand (COD)	NA	81.3%	1.9e-01
Hexane Extractable Material (HEM)	NA	86.1%	1.4e-01
Nitrate/Nitrite	6.2e-05	90.0%	1.0e-01
Total Nitrogen	NA	UNK	UNK
PATHOGENS			
Fecal Coliform (million cfu/day)	NA	99.6%	4.0e-03

¹ TKN is used to calculate Total Nitrogen for baseline loads.

Table F-2
Examples of Toxic Weighting Factors
Based on Copper Freshwater Chronic Criteria

Pollutant	Human Health Criteria (µg/l)	Aquatic Chronic Criteria (µg/l)	Weighting Calculation	Toxic Weighting Factor
Copper*	1,200	9.0	$5.6/1,200 + 5.6/9.0$	0.63
Cadmium	84	2.2	$5.6/84 + 5.6/2.2$	2.6
Naphthalene	21,000	370	$5.6/21,000 + 5.6/370$	0.015

* The water quality criterion has been revised (to 9.0 µg/l). Formerly, the weighting factor calculation led to a result of 0.47 as a toxic weighting factor for copper.

Notes: Human health and aquatic chronic criteria are maximum contamination thresholds. Units for criteria are micrograms of pollutant per liter of water.

criterion for the particular pollutant and the former benchmark copper criterion divided by the aquatic chronic criterion. For example, using the values reported in Table F-2, four pounds of the benchmark chemical (copper) pose the same relative hazard in freshwater as one pound of cadmium because cadmium has a freshwater toxic weight four times greater than the toxic weight of copper (2.6 divided by 0.63 equals 4.13).

F.2.3 POTW Removal Factors

Calculating pound or pound equivalent removals for direct dischargers differs from calculating removals for indirect dischargers because of the ability of POTWs to remove certain pollutants. The POTW removal factors are used as follows: if a facility is discharging 100 pounds of chromium in its effluent stream to a POTW and the POTW has a 80 percent removal efficiency for chromium, then the chromium discharged to surface waters is only 20 pounds (1 minus 0.8 equals 0.2). If the regulation reduces chromium discharged in the effluent stream to the POTW by 50 pounds, then the amount discharged to surface waters is calculated as 50 pounds multiplied by the POTW removal factor (50 pounds times 0.2 equals 10 pounds). The cost effectiveness calculations then reflect the fact that the actual reduction of pollutant discharged to surface water is not 50 pounds (the change in the amount discharged to the POTW), but 10 pounds (the change in the amount actually discharged to surface water). A pollutant discharge that is unaffected by the POTW has a removal factor of 1.

F.2.4 Pollutant Removals And Pounds Equivalent Calculations

The pollutant loadings have been calculated for each facility under each regulatory pollution control option for comparison with baseline (i.e., current practice) loadings. Pollutant removals are calculated simply as the difference between current and post-treatment discharges. For toxic pollutants, these removals are converted into pounds equivalent for the cost effectiveness analysis. For direct dischargers, removals in pounds equivalent for toxic pollutants are calculated as:

$$\text{Removals}_{\text{pe}} = \text{Removals}_{\text{pounds}} \times \text{Toxic weighting factor}$$

For indirect dischargers, removals in pounds equivalent for toxic pollutants are calculated as:

$$\text{Removals}_{\text{pe}} = \text{Removals}_{\text{pounds}} \times \text{Toxic weighting factor} \times \text{POTW removal factor}$$

Total removals for each option are then calculated by adding up the removals of all pollutants included in the cost effectiveness analysis for a given subcategory for both toxic pollutants and nutrients.

F.2.5 Calculation Of Incremental Cost Effectiveness Values

Cost effectiveness ratios are calculated separately for direct and indirect dischargers and by subcategory. Within each of these many groupings, the pollution control options are ranked in ascending order of pounds equivalent removed. The incremental cost effectiveness value for a particular control option is calculated as the ratio of the incremental annual cost to the incremental pounds equivalent removed. The incremental effectiveness may be viewed primarily in comparison to the baseline scenario and to other regulatory pollution control options. Cost effectiveness values are reported in units of dollars per pound equivalent of pollutant removed.

For the purpose of comparing cost effectiveness values of options under review to those of other promulgated rules, compliance costs used in the cost effectiveness analysis are adjusted to 1981 dollars using *Engineering News Record's* Construction Cost Index (CCI; ENR 2000). The adjustment factor is calculated as follows:

$$\text{Adjustment factor} = 1981 \text{ CCI} / 1999 \text{ CCI} = 3535 / 6059 = 0.583$$

The equation used to calculate the incremental cost effectiveness of option k is:

$$CE_k = \frac{ATC_k - ATC_{k-1}}{PE_k - PE_{k-1}}$$

where:

CE_k	=	Cost effectiveness of Option k
ATC_k	=	Total pretax annualized treatment cost under Option k
PE_k	=	Pounds equivalent removed by Option k

Cost effectiveness measures the incremental unit cost of pollutant removal of Option k (in pounds equivalent) in comparison to Option k-1. The numerator of the equation, ATC_k minus ATC_{k-1} , is simply the incremental annualized treatment cost in moving from Option k-1 to Option k. Similarly, the denominator is the incremental removals achieved in going from Option k-1 to k. The lower the value of the incremental CE calculation, the lower the cost of each additional pound equivalent of pollutants removed under that option.

F.2.6 Cost-Effective Results for Toxic Pollutants

F.2.6.1 Subcategory Cost Effectiveness

Table F-3 shows the average and incremental CE figures for non-small direct (BAT) and indirect (PSES) dischargers in all subcategories using upper-bound costs (see the introduction to Chapter 5 for the distinction between upper-bound and retrofit costs). For direct dischargers, incremental CE ranges from \$45 per pound under BAT 2 in Subcategory K to a high of \$286,000 for BAT 3 in Subcategory A through D.³ Cost effectiveness for indirect dischargers ranges from a low of \$17 under PSES 1 for Subcategories A through D and K to a high of \$31,000 for PSES 4 under Subcategory A through D. Note that negative CE values can occur if either estimated annualized compliance costs or estimated pollutant removals are lower for option k than for option k-1. This can be observed in Subcategory E through I, for example, where costs for PSES 3 are lower than for PSES 2, and pollutant removals for PSES 4 are lower than for PSES 3.

³ EPA determined that all non-small direct dischargers have sufficient treatment in place to meet BAT 1 standards, therefore there are no costs or removals associated with that option.

**Table F-3
Results of Cost Effective Analysis
Upper-Bound Costs for Non-small Facilities**

Regulatory Option	Pretax Annualized Costs (Millions of \$1999)	Pollutant Removals (Pounds Equivalent)	Pretax Average Cost Effectiveness (\$1981 Per Pound Equivalent Removed)	Pretax Incremental Cost Effectiveness (\$1981 Per Pound Equivalent Removed)
<i>Subcategory A through D</i>				
BAT 2	\$9.93	93,586	\$62	\$62
BAT 3	\$59.52	93,687	\$371	\$286,414
BAT 4	\$117.98	94,195	\$731	\$67,154
<i>Subcategory B through D</i>				
PSES 1	\$7.05	240,421	\$17	\$17
PSES 2	\$151.49	310,768	\$284	\$1,198
PSES 3	\$96.25	309,081	\$182	\$19,107
PSES 4	\$120.64	309,541	\$227	\$30,955
<i>Subcategory E through I</i>				
BAT 2	\$0.40	2,609	\$90	\$90
BAT 3	\$0.69	2,618	\$154	\$18,512
BAT 4	\$7.01	2,615	\$1,564	(\$1,261,372)
<i>Subcategory C through I</i>				
PSES 1	\$18.79	76,890	\$143	\$143
PSES 2	\$102.09	78,831	\$756	\$25,036
PSES 3	\$83.68	78,855	\$619	(\$440,522)
PSES 4	\$110.20	78,813	\$816	(\$367,437)
<i>Subcategory J</i>				
BAT 2	\$0.55	1,550	\$208	\$208
BAT 3	\$5.80	1,621	\$2,089	\$43,028
BAT 4	\$6.31	1,553	\$2,370	(\$4,333)

**Table F-3 (cont.)
Results of Cost Effective Analysis
Upper-Bound Costs for Non-small Facilities**

Regulatory Option	Pretax Annualized Costs (Millions of \$1999)	Pollutant Removals (Pounds Equivalent)	Pretax Average Cost Effectiveness (\$1981 Per Pound Equivalent Removed)	Pretax Incremental Cost Effectiveness (\$1981 Per Pound Equivalent Removed)
PSES 1	\$1.33	3,918	\$198	\$198
PSES 2	\$23.25	4,983	\$2,723	\$12,011
PSES 3	\$27.91	5,112	\$3,185	\$21,075
PSES 4	\$29.22	4,951	\$3,443	(\$4,757)
<i>Subcategory K</i>				
BAT 2	\$4.82	63,192	\$45	\$45
BAT 3	\$48.37	64,094	\$440	\$28,181
BAT 4	\$61.25	64,029	\$558	(\$115,860)
BAT5	\$66.09	65,169	\$592	\$2,479
PSES 1	\$10.84	377,651	\$17	\$17
PSES 2	\$188.95	382,550	\$288	\$21,212
PSES 3	\$133.01	382,735	\$203	(\$176,292)
PSES 4	\$136.54	381,751	\$209	(\$2,093)
<i>Subcategory L</i>				
BAT 2	\$0.30	373	\$472	\$472
BAT 3	\$2.95	383	\$4,494	\$160,314
BAT 4	\$4.32	371	\$6,796	(\$70,689)
BAT 5	\$3.85	398	\$5,645	(\$10,190)
PSES 1	\$15.26	49,950	\$178	\$178
PSES 2	\$105.33	51,257	\$1,199	\$40,224
PSES 3	\$74.56	51,367	\$847	(\$162,814)
PSES 4	\$94.11	51,237	\$1,072	(\$87,885)

Average CE tables for non-small direct and indirect dischargers based on retrofit costs are presented in Table F-4.⁴ Option BAT 2 under Subcategory K has the lowest average CE value for a direct discharger at \$45 and BAT 5 under Subcategory L has the highest average CE at more than \$5,600. Among indirect dischargers, PSES 1 for Subcategories A through D and K has the lowest average CE at \$17 and PSES 4 under Subcategory J has the highest at \$2,900.

Table F-5 shows the average and incremental CE figures for small direct and indirect dischargers in all subcategories using upper-bound costs.⁵ For small direct dischargers, CE values range from a low of \$300 under BAT 2 for Subcategory A through D to a high of more than \$31 million for BAT 3 in the same subcategory. Cost effectiveness values for small indirect dischargers range from a low of \$39 under PSES 1 for Subcategory K to a high of \$802 million under PSES 3 for Subcategory E through I.

Detailed tables containing toxic pollutant removals and baseline loads for non-small and small facilities for each subcategory and both discharge types can be found in Section F.5.

F.2.6.2 Industry Cost Effectiveness

For the proposed options, EPA selected BAT 3 for all direct discharging non-small facilities in Subcategories A through D, E through I, K and L, and BAT 2 for Subcategory J. For small direct dischargers in subcategories K and L, EPA selected option BAT 1. Table F-6 lists the incremental annualized cost and the incremental removals under the proposed options for each subcategory using the upper-bound costs. The incremental costs and removals are then totaled, and costs divided by removals to calculate the industry cost effectiveness ratio. For all direct dischargers, the industry CE ratio is about \$21,900 per incremental pound equivalent removed based on upper-bound costs.

⁴ Upgrade costs were estimated for options 3 and 4 only. Hence, incremental CE values could not be calculated for upgrade costs and average CE values are presented instead.

⁵ EPA did not estimate retrofit costs for small facilities. The incremental CE of option 2 is undefined in some subcategories because incremental removals for the option are zero.

Table F-4
Results of Cost Effective Analysis
Retrofit Costs for Non-small Facilities

Regulatory Option	Pretax Annualized Costs (Millions of \$1999)	Pollutant Removals (Pounds Equivalent)	Pretax Average Cost Effectiveness (\$1981 per Pound Equivalent Removed)
<i>Subcategory A through D</i>			
BAT 2	\$9.93	93,586	\$62
BAT 3	\$42.25	93,687	\$263
BAT 4	\$73.53	94,195	\$455
<i>Subcategory E through I</i>			
PSES 1	\$7.05	240,421	\$17
PSES 2	\$151.49	310,768	\$284
PSES 3	\$86.42	309,081	\$163
PSES 4	\$105.86	309,541	\$200
<i>Subcategory J</i>			
BAT 2	\$0.55	1,550	\$208
BAT 3	\$4.28	1,621	\$1,540
BAT 4	\$4.98	1,553	\$1,871

**Table F-4 (cont.)
Results of Cost Effective Analysis
Retrofit Costs for Nonsmall Facilities**

Regulatory Option	Pretax Annualized Costs (Millions of \$1999)	Pollutant Removals (Pounds Equivalent)	Pretax Average Cost Effectiveness (\$1981 per Pound Equivalent Removed)
PSES 1	\$1.33	3,918	\$198
PSES 2	\$23.25	4,983	\$2,723
PSES 3	\$23.09	5,112	\$2,635
PSES 4	\$24.78	4,951	\$2,920
<i>Subcategory K</i>			
BAT 2	\$4.82	63,192	\$45
BAT 3	\$34.46	64,094	\$314
BAT 4	\$44.21	64,029	\$403
BAT5	\$66.09	65,169	\$592
PSES 1	\$10.84	377,651	\$17
PSES 2	\$188.95	382,550	\$288
PSES 3	\$126.00	382,735	\$192
PSES 4	\$131.39	381,751	\$201
<i>Subcategory L</i>			
BAT 2	\$0.30	373	\$472
BAT 3	\$2.18	383	\$3,329
BAT 4	\$3.03	371	\$4,769
BAT 5	\$3.85	398	\$5,645
PSES 1	\$15.26	49,950	\$178
PSES 2	\$105.33	51,257	\$1,199
PSES 3	\$74.25	51,367	\$843
PSES 4	\$93.89	51,237	\$1,069

Table F-5
Results of Cost Effective Analysis
Upper-Bound Costs for Small Facilities

Regulatory Option	Pretax Annualized Costs (Millions of \$1999)	Pollutant Removals (Pounds Equivalent)	Pretax Incremental Cost Effectiveness (\$1981 Per Pound Equivalent Removed)	Pretax Incremental Cost Effectiveness (\$1981 Per Pound Equivalent Removed)
<i>Subcategory A through D</i>				
BAT 1	\$0.03	53.5	\$318	\$318
BAT 2	\$0.51	53.5	\$5,534	Undefined
BAT 3	\$4.30	53.6	\$46,767	\$31,294,686
<i>Subcategory E through I</i>				
PSES 1	\$29.99	2,819	\$6,207	\$6,207
PSES 2	\$162.40	3,315	\$28,577	\$155,629
PSES 3	\$152.53	3,299	\$26,972	\$355,314
PSES 4	\$172.79	3,304	\$30,514	\$2,659,229
<i>Subcategory J</i>				
BAT 1	\$0.00	596	\$0	Undefined
BAT 2	\$0.17	596	\$169	Undefined
BAT 3	\$1.77	624	\$1,659	\$33,007

**Table F-5 (cont.)
Results of Cost Effective Analysis
Upper-Bound Costs for Small Facilities**

Regulatory Option	Pretax Annualized Costs (Millions of \$1999)	Pollutant Removals (Pounds Equivalent)	Pretax Incremental Cost Effectiveness (\$1981 Per Pound Equivalent Removed)	Pretax Incremental Cost Effectiveness (\$1981 Per Pound Equivalent Removed)
PSES 1	\$0.81	10,348	\$46	\$46
PSES 2	\$10.64	10,654	\$583	\$18,737
PSES 3	\$7.59	10,657	\$416	(\$571,582)
PSES 4	\$7.89	10,644	\$432	(\$13,042)
<i>Subcategory K</i>				
BAT 1	NA	NA	NA	NA
BAT 2	NA	NA	NA	NA
BAT 3	NA	NA	NA	NA
PSES 1	\$1.42	21,071	\$39	\$39
PSES 2	\$6.02	21,079	\$167	\$327,850
PSES 3	\$6.62	21,080	\$183	\$1,140,580
PSES 4	\$7.40	21,078	\$205	(\$317,057)
<i>Subcategory L</i>				
BAT 1	\$0.003	1.4	\$1,299	\$1,299
BAT 2	\$0.03	1.4	\$11,932	Undefined
BAT 3	\$0.21	1.4	\$85,033	\$8,811,023
PSES 1	\$27.29	1,034	\$15,398	\$15,398
PSES 2	\$101.36	1,053	\$56,182	\$2,320,089
PSES 3	\$94.67	1,054	\$52,403	(\$2,957,132)
PSES 4	\$104.62	1,052	\$58,001	(\$3,750,193)

Table F-6
Incremental Cost Effectiveness of Proposed Pollutant Control Options
Upper-Bound for Direct Dischargers

Size	Regulatory Option	Incremental		
		Pretax Annualized Cost (Millions of \$1999)	Pounds Equivalent Removed	Cost Effectiveness (\$1981/Pounds Equivalent)
<i>Subcategory A through D</i>				
Nonsmalls	BAT 3	\$49.59	101	\$286,414
<i>Subcategory E through I</i>				
Non-Small	BAT 3	\$0.29	9	\$18,512
<i>Subcategory J</i>				
Nonsmalls	BAT 2	\$0.55	1,550	\$208
<i>Subcategory K</i>				
Nonsmalls	BAT 3	\$43.55	902	\$28,181
Smalls	BAT 1	NA	NA	NA
<i>Subcategory L</i>				
Nonsmalls	BAT 3	\$2.65	10	\$160,314
Smalls	BAT 1	\$0.003	1	\$1,299
Industry Total		\$96.62	2,573	\$21,897

Table F-7 calculates and compares the industry average cost effectiveness values for the proposed pollutant control options using upper-bound costs and retrofit costs for non-small facilities. The average CE ratio for the industry is \$401 per pound-equivalent using the upper-bound costs, and \$287 per pound based on retrofit costs.

Table F-8 summarizes the cost effectiveness of the proposed option for direct dischargers in the meat products industry relative to that of other industries.

F.3 COST REASONABLENESS ANALYSIS

F.3.1 Pollutants of Concern and Methodology

EPA selected four nonconventional pollutants to perform the cost reasonableness analysis: chemical oxygen demand (COD), hexane extractable material (HEM), nitrate/nitrite, and total nitrogen. Table F-9 presents the nonconventional pollutant chosen for each option under the different subcategories. EPA calculates cost reasonableness as the average cost per pound removed of the selected pollutant under each regulatory option. Cost reasonableness applies to direct discharging subcategories only. EPA has historically considered ratios as high as \$37 per pound to be cost reasonable.

F.3.2 Results

Table F-10 presents the cost reasonableness results using both upper-bound and retrofit costs for nonsmall facilities in all subcategories. Based on upper-bound costs, BAT 4 in Subcategory L has the highest cost reasonableness value of almost \$14 per pound of pollutant removed (in 1999 dollars). The use of retrofit costs lowers that value to about \$10 per pound. The lowest cost per pound removed occurs under BAT 2 in Subcategory J at about \$0.03 per pound, which is the proposed option for this subcategory. Under the proposed option BAT 3 in all subcategories except J, cost reasonableness figures range from \$6.60 to \$9.60 per pound in subcategories K and L, to less than \$1.60 in subcategories A through D and E through I.

Table F-7
Average Cost Effectiveness of Proposed Pollutant Control Options
Upper-Bound and Retrofit Costs for Direct Dischargers

Size	Regulatory Option	Pretax Annualized Cost (Millions of \$1999)		Pounds Equivalent Removed	Average Cost Effectiveness (\$1981/Pounds Equivalent)	
		Upper-Bound	Retrofit		Upper-Bound	Retrofit
<i>Subcategory A through D</i>						
Nonsmalls	BAT 3	\$59.52	\$42.25	93,687	\$371	\$263
<i>Subcategory E through I</i>						
Non-Small	BAT 3	\$0.69	\$0.40	2,618	\$154	\$90
<i>Subcategory J</i>						
Nonsmalls	BAT 2	\$0.55	\$0.55	1,550	\$208	\$208
<i>Subcategory K</i>						
Nonsmalls	BAT 3	\$48.37	\$34.46	64,094	\$440	\$314
Smalls	BAT 1	NA	NA	NA	NA	NA
<i>Subcategory L</i>						
Nonsmalls	BAT 3	\$2.95	\$2.18	383	\$4,494	\$3,329
Smalls	BAT 1	\$0.003	\$0.003	1	\$1,299	\$1,299
Industry Total		\$112.09	\$79.84	162,333	\$401	\$287

Table F-8
Industry Comparison of BAT Cost Effectiveness
For Direct Dischargers
(Toxic and Nonconventional Pollutants Only; Copper-Based Weights^a; \$1981)

Industry	Pounds Equivalent Currently Discharged (thousands)	Pounds Equivalent Remaining at Selected Option (thousands)	Incremental Cost Effectiveness of Selected Option(s) (\$ / Pounds Equivalent Removed)
Aluminum Forming	1,340	90	121
Battery Manufacturing	4,126	5	2
Canmaking	12	0.2	10
Centralized Waste Treatment ^c	3,372	1,261-1,267	5-7
Coal Mining	BAT=BPT	BAT=BPT	BAT=BPT
Coil Coating	2,289	9	49
Copper Forming	70	8	27
Electronics I	9	3	404
Electronics II	NA	NA	NA
Foundries	2,308	39	84
Inorganic Chemicals I	32,503	1,290	<1
Inorganic Chemicals II	605	27	6
Iron & Steel	1,740	1,214	66
Leather Tanning	259	112	BAT=BPT
Meat Products (Proposed)	169	7	\$21,900
Metal Finishing	3,305	3,268	12
Metal Products and Machinery ^c	140	70	50
Nonferrous Metals Forming	34	2	69
Nonferrous Metals Mfg I	6,653	313	4
Nonferrous Metals Mfg II	1,004	12	6
Oil and Gas: Offshore ^b	3,809	2,328	33
Coastal/Produced Water/TWC	951	239	35
Drilling Waste	BAT = Current Practice	BAT = Current Practice	BAT = Current Practice
Organic Chemicals	54,225	9,735	5
Pesticides	2,461	371	14
Pharmaceuticals ^c A/C	897	47	47
B/D	90	0.5	96
Plastics Molding & Forming	44	41	BAT=BPT
Porcelain Enameling	1,086	63	6
Petroleum Refining	BAT=BPT	BAT=BPT	BAT=BPT
Pulp & Paper ^c	61,713	2,628	39
Textile Mills	BAT=BPT	BAT=BPT	BAT=BPT
Transportation Equipment Cleaning	BAT=BPT	BAT=BPT	BAT=BPT

^aAlthough toxic weighting factors for priority pollutants varied across these rules, this table reflects the cost-effectiveness at the time of regulation.

^bProduced water only; for produced sand and drilling fluids and drill cuttings, BAT=NSPS.

ND: Nondisclosed due to business confidentiality.

**Table F-9
Pollutants Selected for Cost-Reasonableness Analysis**

Regulatory Option	Pollutant
<i>Subcategory A through D</i>	
BAT 2	HEM
BAT 3	Nitrate/Nitrite
BAT 4	Nitrate/Nitrite
<i>Subcategory E through I</i>	
BAT 2	HEM
BAT 3	Total Nitrogen
BAT 4	Total Nitrogen
<i>Subcategory J</i>	
BAT 2	COD
BAT 3	COD
BAT 4	COD
<i>Subcategory K</i>	
BAT 2	COD
BAT 3	Total Nitrogen
BAT 4	Total Nitrogen
BAT5	Total Nitrogen
<i>Subcategory L</i>	
BAT 2	HEM
BAT 3	Total Nitrogen
BAT 4	Total Nitrogen
BAT 5	Total Nitrogen

Table F-10
Cost Reasonableness Estimates
Nonsmall Direct Dischargers

Regulatory Option	Removals (Millions of lbs.)	Retrofit Costs		Upper-Bound Costs	
		Pretax Total Annualized Cost (Millions of \$1999)	Average Cost/Pound Removal (\$/lb.)	Pretax Total Annualized Cost (Millions of \$1999)	Average Cost/Pound Removal (\$/lb.)
<i>Subcategory A through D</i>					
BAT 2	12.30	\$9.9	\$0.81	\$9.9	\$0.81
BAT 3	38.70	\$42.2	\$1.09	\$59.5	\$1.54
BAT 4	41.00	\$73.5	\$1.79	\$118.0	\$2.88
<i>Subcategory E through I</i>					
BAT 2	0.25	\$0.4	\$1.59	\$0.4	\$1.59
BAT 3	2.01	\$0.5	\$0.27	\$0.7	\$0.34
BAT 4	2.02	\$3.5	\$1.74	\$7.0	\$3.47
<i>Subcategory J</i>					
BAT 2	18.30	\$0.6	\$0.03	\$0.6	\$0.03
BAT 3	18.30	\$4.3	\$0.23	\$5.8	\$0.32
BAT 4	18.10	\$5.0	\$0.27	\$6.3	\$0.35
<i>Subcategory K</i>					
BAT 2	1.63	\$4.8	\$2.95	\$4.8	\$2.95
BAT 3	7.32	\$34.5	\$4.71	\$48.4	\$6.61
BAT 4	8.10	\$44.2	\$5.46	\$61.3	\$7.56
BAT 5	8.00	\$66.1	\$8.23	\$66.1	\$8.26
<i>Subcategory L</i>					
BAT 2	0.09	\$0.3	\$3.28	\$0.3	\$3.28
BAT 3	0.31	\$2.2	\$7.11	\$2.9	\$9.60
BAT 4	0.32	\$3.0	\$9.54	\$4.3	\$13.59
BAT 5	0.32	\$3.9	\$11.97	\$3.9	\$11.97

F.4 COST EFFECTIVENESS METHODOLOGY AND RESULTS: NUTRIENTS

In addition to conducting a standard CE analysis for selected toxic pollutants (Section F.2), EPA also evaluates the cost effectiveness of removing selected nonconventional pollutants: nutrients, primarily nitrogen and phosphorus. The methodology for this analysis has been drawn from the economic impact analysis of the Concentrated Animal Feeding Operations Industry (U.S. EPA, 2001).

The nutrient cost effectiveness analysis does not follow the methodological approach of a standard CE analysis. Instead, this analysis compares the estimated compliance cost per pound of pollutant removed to benchmarks, such as those reported in available cost effectiveness studies. A review of this literature is provided in Section F.4.1. EPA uses these estimates to evaluate the efficiency of regulatory options in removing nutrients and to compare the proposed BAT options to other regulatory alternatives (Section F.4.2).

F.4.1 Review of Literature

EPA has reviewed the available information on pollutant removal costs for nutrients. This research can be broadly grouped according to estimates derived for industrial point sources (PS) and various nonpoint sources (NPS), including agricultural operations. In general, the PS research provides information on technology and retrofitting costs — and in some cases, cost per pound of pollutant removed — at municipal facilities, including publicly owned treatment works (POTWs) and wastewater treatment plants (WWTPs). This research utilizes actual cost data collected at a particular facility undergoing an upgrade. Other cost effectiveness research is based on the effectiveness of various nonpoint source controls, such as Best Management Practices (BMPs) and other pollutant control technologies that are commonly used to control runoff from agricultural lands. This research typically uses a modeling approach and simulates costs for a representative facility. The latter studies are less relevant to the proposed meat products industry effluent guidelines.

EPA reviewed the literature on nutrient cost-effectiveness; Table F-11 summarizes the cost effectiveness values reported in these studies. These studies estimate a wide range of costs per pound of

Table F-11
Summary of Pollutant Removal Cost Estimates and Benchmarks

Type of Pollutant	Low Estimate	High Estimate	Treatment Type	Literature Sources
	(\$ per pound removed)			
Total Nitrogen (TN)	(\$0.79)	\$5.92	WWTPs	Randall et al (1999)
	--	\$3.64	WWTPs	Wiedeman (2000)
	\$0.91	\$9.53	Aerobic Lagoon	Tippett and Dodd (1995)
Total Phosphorus (TP)	\$9.64	\$165.00	Ag.(low) to municipal	NEWWT 1994
	\$270.34	\$1,179.35	Large Point Source	LCBP (1995)
	\$2.72	\$135.17	Aerobic Lagoon	Tippett and Dodd (1995)

WWTPs = Waste Water Treatment Plants; POTWs = Publicly owned treatment works.

Full citations are provided in references. Timeframe of dollar values shown vary by source (shown below).

Notes summarize timeframe of analysis, study assumptions (where available), and range of sources/treatment.

Randall (2000): 1995-1998; 6% interest and 20-year capital renewal; BNR retrofits at WWTP only.

NEWWT (1994): 5% interest and 20-year capital renewal; low bound is agricultural BMPs and higher bound is municipal treatment facilities.

McCarthy, et. al. (1996): No discount rate was applied and annual cost equals total lifetime costs adjusted by design life (varies by practice); study also examined agricultural land application (both with varying increasing over-application of land applied manure under pre-existing conditions). Cost-effectiveness values that assume direct discharge of animal wastes are not shown.

LCBP (2000): 1995: No discount rate was applied and annual cost equals total lifetime costs adjusted by design life (varies by practice); study also examined agricultural BMPs.

pollutant removed, spanning both point source and nonpoint sources, as well as a range of municipal, urban, and agricultural practices. Annualized costs also vary widely depending on a variety of factors, including the type of treatment system or practice evaluated, and whether the costs are evaluated as a retrofit to an existing operation or as construction of a new facility.

Researchers at Virginia Tech compiled a series of case studies that evaluated total costs for biological nutrient removal (BNR) retrofits at WWTPs throughout the Chesapeake Bay Watershed (Randall et al., 1999). These case studies estimated a range of costs per pound of nitrogen removed at these facilities. This research was commissioned by EPA's Chesapeake Bay Program and was conducted with the assistance of the Maryland Department of the Environment and the Public Utilities Division of Anne Arundel County. As part of this work, the researchers estimate BNR retrofit costs for 51 WWTPs located in Maryland, Pennsylvania, Virginia, and New York. The final report in this series compares these costs to the projected change in effluent total nitrogen concentrations, assuming that the influent flow meets the design or projected flow after 20 years (Randall, et al., 1999).

As shown in Table F-11, this study concludes that the costs of nitrogen removal are very plant-specific and the costs per pound of additional nitrogen removal ranged from a projected savings of \$0.79 per pound to a cost of 5.92 per pound (Randall et al., 1999).⁶ The range of these estimates is comparatively narrow given that the study examines a single retrofit category across similar facilities. This study assumes a 20-year capital renewal period and interest and inflation rates of 6 and 3 percent, respectively (Randall, 2000). The primary emphasis in this study is nitrogen, since the cost to upgrade for phosphorus removal is both configuration- and site-specific (Randall, 2000).⁷ Based on this analysis and other data from the Maryland Department of the Environment, EPA's Chesapeake Bay Program Office derived a cost effectiveness value for BNR of \$3.64 per pound of nitrogen removed (Wiedeman, 1998).

⁶ The costs per pound of additional nitrogen removed were flow-weighted to determine the average for each state and for all plants evaluated.

⁷ For conventional plug-flow activated sludge configurations, all that is required for phosphorus removal is the installation of relatively low-cost baffles and mixers; for oxidation ditches, the addition of an anaerobic reactor separate from the ditch is needed (Randall, 2000).

A number of other studies have assessed the cost effectiveness of various state-level programs to reduce nutrients in Wisconsin (NEWWT, 1994) and Vermont (LCBP, 2000). In Wisconsin, a series of studies compared the cost effectiveness of point and nonpoint source controls across 41 subwatersheds in the Fox-Wolf watershed in Wisconsin (NEWWT, 1994). These studies estimated the cost of reducing phosphorus and suspended solids (TSS) loads from municipal treatment facilities and agricultural sources. Baseline projections were compared to necessary reductions to meet future water quality objectives (as mandated by that State's current regulations). Phosphorus removal costs for rural sources are estimated to be \$9.64 per pound, while municipal treatment facilities have an estimated average annual cost of \$165 per pound of phosphorus removed (NEWWT, 1994).

The Lake Champlain Basin Program (LCBP) conducted a similar study to evaluate costs to meet Vermont's water quality goals. This study estimated phosphorus removal costs ranging from \$270 to more than \$1,000 per pound at a large municipal facility, compared to \$440 to \$544 per pound of phosphorus removed using agricultural BMPs (LCBP, 2000). In addition, researchers at Virginia Tech who estimated removal costs for nitrogen at WWTPs conclude that it will cost about the same to remove a pound of phosphorus as it costs to remove a pound of nitrogen, if removing only one nutrient. If the facility is upgraded to remove both nitrogen and phosphorus, the cost typically will be only slightly more than the cost to remove nitrogen alone (Randall, 2000).

F.4.2 Results of Nutrient Cost-Effective Analysis

Tables F-12 and F-13 present the cost per pound of total nitrogen removals by subcategory and option.⁸ For direct dischargers, the average cost per pound of nitrogen removed ranges from \$0.34 under BAT 3 in Subcategory E through I, to more than \$15 (upper-bound costs) under BAT 3 in Subcategory J (Table F-12). For indirect dischargers, the average cost per pound of nitrogen removed ranges from \$0.16 under PSES 1 in Subcategory J, to about \$40 (upper-bound costs) under PSES 4 in Subcategory E through I

⁸ No nitrogen is removed under option 2. The technology for option 2 includes nitrification but not denitrification. Therefore nitrogen is not removed from the wastewater but is instead converted to nitrate/nitrite (see Development Document, U.S. EPA, 2002).

Table F-12
Average Cost Effectiveness of Proposed Pollutant Control Options–Total Nitrogen
Upper-Bound and Retrofit Costs for Non-small Direct Dischargers

Regulatory Option	Pretax Annualized Cost (Millions of \$1999)		Total Pounds Removed	Average Cost Effectiveness (\$1999/Pounds)	
	Upper-Bound	Retrofit		Upper-Bound	Retrofit
<i>Subcategory A through D</i>					
BAT 2	\$9.93	NA	0	Undefined	NA
BAT 3	\$59.52	\$42.25	38,192,320	\$1.56	\$1.11
BAT 4	\$117.98	\$73.53	40,290,551	\$2.93	\$1.82
<i>Subcategory E through I</i>					
BAT 2	\$0.40	NA	0	Undefined	NA
BAT 3	\$0.69	\$0.54	2,010,906	\$0.34	\$0.27
BAT 4	\$7.01	\$3.53	2,023,173	\$3.47	\$1.74
<i>Subcategory J</i>					
BAT 2	\$0.55	NA	0	Undefined	NA
BAT 3	\$5.80	\$4.28	378,836	\$15.32	\$11.30
BAT 4	\$6.31	\$4.98	433,771	\$14.55	\$11.48

Table F-12 (cont.)
Average Cost Effectiveness of Proposed Pollutant Control Options–Total Nitrogen
Upper-Bound and Retrofit Costs for Non-small Direct Dischargers

Regulatory Option	Pretax Annualized Cost (Millions of \$1999)		Total Pounds Removed	Average Cost Effectiveness (\$1999/Pounds)	
	Upper-Bound	Retrofit		Upper-Bound	Retrofit
<i>Subcategory K</i>					
BAT 2	\$4.82	NA	0	Undefined	NA
BAT 3	\$48.37	\$34.46	7,320,643	\$6.61	\$4.71
BAT 4	\$61.25	\$44.21	8,101,809	\$7.56	\$5.46
BAT 5	\$66.09	NA	8,032,409	\$8.23	NA
<i>Subcategory L</i>					
BAT 2	\$0.30	NA	0	Undefined	NA
BAT 3	\$2.95	\$2.18	307,076	\$9.60	\$7.11
BAT 4	\$4.32	\$3.03	318,194	\$13.59	\$9.54
BAT 5	\$3.85	NA	321,809	\$11.97	NA

Table F-13
Average Cost Effectiveness of Proposed Pollutant Control Options–Nitrogen
Upper-Bound and Retrofit Costs for Non-small Indirect Dischargers

Regulatory Option	Pretax Annualized Cost (Millions of \$1999)		Total Pounds Removed	Average Cost Effectiveness (\$1999/Pounds)	
	Upper-Bound	Retrofit		Upper-Bound	Retrofit
<i>Subcategory A through D</i>					
PSES 1	\$7.05	NA	0	Undefined	NA
PSES 2	\$151.49	NA	0	Undefined	NA
PSES 3	\$96.25	\$86.42	31,518,545	\$3.05	\$2.74
PSES 4	\$120.64	\$105.86	32,896,309	\$3.67	\$3.22
<i>Subcategory E through I</i>					
PSES 1	\$18.79	NA	1,309,195	\$14.35	NA
PSES 2	\$102.09	NA	0	Undefined	NA
PSES 3	\$83.68	\$83.25	2,736,823	\$30.58	\$30.42
PSES 4	\$110.20	\$109.82	2,811,178	\$39.20	\$39.07
<i>Subcategory J</i>					
PSES 1	\$1.33	NA	8,114,088	\$0.16	NA
PSES 2	\$23.25	NA	0	Undefined	NA
PSES 3	\$27.91	\$23.09	10,023,243	\$2.78	\$2.30
PSES 4	\$29.22	\$24.78	10,216,804	\$2.86	\$2.43

Table F-13 (cont.)
Average Cost Effectiveness of Proposed Pollutant Control Options–Nitrogen
Upper-Bound and Retrofit Costs for Non-small Indirect Dischargers

Regulatory Option	Pretax Annualized Cost (Millions of \$1999)		Total Pounds Removed	Average Cost Effectiveness (\$1999/Pounds)	
	Upper-Bound	Retrofit		Upper-Bound	Retrofit
<i>Subcategory K</i>					
PSES 1	\$10.84	NA	3,849,894	\$2.82	NA
PSES 2	\$188.95	NA	0	Undefined	NA
PSES 3	\$133.01	\$126.00	15,404,773	\$8.63	\$8.18
PSES 4	\$136.54	\$131.39	16,422,369	\$8.31	\$8.00
<i>Subcategory L</i>					
PSES 1	\$15.26	NA	1,983,785	\$7.69	NA
PSES 2	\$105.33	NA	0	Undefined	NA
PSES 3	\$74.56	\$74.25	3,799,359	\$19.63	\$19.54
PSES 4	\$94.11	\$93.89	4,078,127	\$23.08	\$23.02

(Table F-13). The cost per pound of nitrogen removed is generally much lower for direct dischargers than indirect dischargers.

Under the proposed options (BAT 3 for all subcategories except J, for which BAT 2 was selected), cost per pound of nitrogen removed ranges from \$6.60 to almost \$10 (upper-bound costs) in subcategories K and L (\$5 to \$7 for retrofit costs). In subcategories A through D, and E through I, the cost is less than \$1.56 per pound. No nitrogen is removed under the proposed option for Subcategory J.

Tables F-14 and F-15 present the cost per pound of total phosphorus removals by subcategory and option. For direct dischargers, the average cost of phosphorus removals ranges from \$5 per pound under BAT 1 in Subcategory A through D, to \$311 per pound (upper-bound costs) under BAT 5 in Subcategory L (Table F-14). For indirect dischargers, the average cost per pound of phosphorus removed ranges from about \$7 under PSES 1 in Subcategory K, to \$180 (upper-bound costs) under PSES 4 in Subcategory J (Table F-15). For all options except 3 and 4 in subcategories K and L, the cost per pound of phosphorus removed is lower for direct dischargers than indirect dischargers.

Under the proposed options (BAT 3 for all subcategories except J, for which BAT 2 was selected), the cost of phosphorus removals is the highest for Subcategory L (\$225 per pound, upper-bound costs; \$167 per pound retrofit costs) and Subcategory K (\$46 per pound, upper-bound costs; \$33 per pound retrofit costs). In subcategories A through D, E through I, and J, the costs are less than \$13 per pound (upper-bound costs) and \$9 per pound (retrofit costs).

Tables F-16 and F-17 present the cost per pound of total nutrient removals by subcategory and option. In all subcategories, the cost per pound of nutrients removed is lower for direct dischargers than for indirect dischargers, often substantially lower. Among direct dischargers the cost of total nutrient removals is less than \$1.50 per pound in Subcategory A through D and E through I, and less than \$7.00 per pound for Subcategory J under the proposed options. The highest cost per pound under the proposed options is found in Subcategory L, and that does not exceed \$10; for Subcategory K, the cost is less than \$6 per pound of nutrients removed.

Table F-14
Average Cost Effectiveness of Proposed Pollutant Control Options—Phosphorus
Upper-Bound and Retrofit Costs for Non-small Direct Dischargers

Regulatory Option	Pretax Annualized Cost (Millions of \$1999)		Total Pounds Removed	Average Cost Effectiveness (\$1999/Pounds)	
	Upper-Bound	Retrofit		Upper-Bound	Retrofit
<i>Subcategory A through D</i>					
BAT 2	\$9.93	NA	1,972,012	\$5	NA
BAT 3	\$59.52	\$42.25	4,626,000	\$13	\$9
BAT 4	\$117.98	\$73.53	4,626,000	\$26	\$16
<i>Subcategory E through I</i>					
BAT 2	\$0.40	\$9.93	35,700	\$11	NA
BAT 3	\$0.69	\$0.54	104,733	\$7	\$5
BAT 4	\$7.01	\$3.53	97,026	\$72	\$36
<i>Subcategory J</i>					
BAT 2	\$0.55	\$9.93	86,772	\$6	NA
BAT 3	\$5.80	\$4.28	103,388	\$56	\$41
BAT 4	\$6.31	\$4.98	97,425	\$65	\$51

Table F-14 (cont.)
Average Cost Effectiveness of Proposed Pollutant Control Options—Phosphorus
Upper-Bound and Retrofit Costs for Non-small Direct Dischargers

Regulatory Option	Pretax Annualized Cost (Millions of \$1999)		Total Pounds Removed	Average Cost Effectiveness (\$1999/Pounds)	
	Upper-Bound	Retrofit		Upper-Bound	Retrofit
<i>Subcategory K</i>					
BAT 2	\$4.82	\$9.93	809,833	\$6	NA
BAT 3	\$48.37	\$34.46	1,051,184	\$46	\$33
BAT 4	\$61.25	\$44.21	768,582	\$80	\$58
BAT 5	\$66.09	\$9.93	823,669	\$80	NA
<i>Subcategory L</i>					
BAT 2	\$0.30	\$9.93	0	Undefined	NA
BAT 3	\$2.95	\$2.18	13,084	\$225	\$167
BAT 4	\$4.32	\$3.03	0	Undefined	Undefined
BAT 5	\$3.85	\$9.93	12,378	\$311	NA

Table F-15
Average Cost Effectiveness of Proposed Pollutant Control Options–Phosphorus
Upper-Bound and Retrofit Costs for Non-small Indirect Dischargers

Regulatory Option	Pretax Annualized Cost (Millions of \$1999)		Total Pounds Removed	Average Cost Effectiveness (\$1999/Pounds)	
	Upper-Bound	Retrofit		Upper-Bound	Retrofit
<i>Subcategory A through D</i>					
PSES 1	\$7.05	NA	907,327	\$8	NA
PSES 2	\$151.49	NA	1,573,317	\$96	NA
PSES 3	\$96.25	\$86.42	2,319,250	\$42	\$37
PSES 4	\$120.64	\$105.86	2,319,250	\$52	\$46
<i>Subcategory E through I</i>					
PSES 1	\$18.79	NA	688,445	\$27	NA
PSES 2	\$102.09	NA	1,510,007	\$68	NA
PSES 3	\$83.68	\$83.25	1,879,812	\$45	\$44
PSES 4	\$110.20	\$109.82	1,792,178	\$61	\$61
<i>Subcategory J</i>					
PSES 1	\$1.33	NA	119,777	\$11	NA
PSES 2	\$23.25	NA	146,708	\$159	NA
PSES 3	\$27.91	\$23.09	171,643	\$163	\$135
PSES 4	\$29.22	\$24.78	162,694	\$180	\$152

Table F-15 (cont.)
Average Cost Effectiveness of Proposed Pollutant Control Options—Phosphorus
Upper-Bound and Retrofit Costs for Non-small Indirect Dischargers

Regulatory Option	Pretax Annualized Cost (Millions of \$1999)		Total Pounds Removed	Average Cost Effectiveness (\$1999/Pounds)	
	Upper-Bound	Retrofit		Upper-Bound	Retrofit
<i>Subcategory K</i>					
PSES 1	\$10.84	NA	1,618,298	\$7	NA
PSES 2	\$188.95	NA	2,827,350	\$67	NA
PSES 3	\$133.01	\$126.00	3,000,203	\$44	\$42
PSES 4	\$136.54	\$131.39	2,794,972	\$49	\$47
<i>Subcategory L</i>					
PSES 1	\$15.26	NA	731,671	\$21	NA
PSES 2	\$105.33	NA	1,893,734	\$56	NA
PSES 3	\$74.56	\$74.25	2,112,594	\$35	\$35
PSES 4	\$94.11	\$93.89	1,858,473	\$51	\$51

Table F-16
Cost Effectiveness of Proposed Pollutant Control Options–Total Nutrients
Upper-Bound and Retrofit Costs for Non-small Direct Dischargers

Option	Pretax Annualized Cost (Millions of \$1999)		Total Pounds Removed	Average Cost Effectiveness (\$1999/Pounds)	
	Upper-Bound Costs	Retrofit Costs		Upper-Bound	Retrofit
<i>Subcategory A through D</i>					
BAT 2	\$9.93	NA	1,972,012	\$5.0	NA
BAT 3	\$59.52	\$42.25	42,818,320	\$1.4	\$1.0
BAT 4	\$117.98	\$73.53	44,916,551	\$2.6	\$1.6
<i>Subcategory E through I</i>					
BAT 2	\$0.40	NA	35,700	\$11.3	NA
BAT 3	\$0.69	\$0.54	2,115,639	\$0.3	\$0.3
BAT 4	\$7.01	\$3.53	2,120,199	\$3.3	\$1.7
<i>Subcategory J</i>					
BAT 2	\$0.55	NA	86,772	\$6.4	NA
BAT 3	\$5.80	\$4.28	482,224	\$12.0	\$8.9
BAT 4	\$6.31	\$4.98	531,196	\$11.9	\$9.4

Table F-16 (cont.)
Cost Effectiveness of Proposed Pollutant Control Options–Nutrients
Upper-Bound and Retrofit Costs for Non-small Direct Dischargers

Option	Pretax Annualized Cost (Millions of \$1999)		Total Pounds Removed	Average Cost Effectiveness (\$1999/Pounds)	
	Upper-Bound Costs	Retrofit Costs		Upper-Bound	Retrofit
<i>Subcategory K</i>					
BAT 2	\$4.82	NA	809,883	\$6.0	NA
BAT 3	\$48.37	\$34.46	8,371,827	\$5.8	\$4.1
BAT 4	\$61.25	\$44.21	8,870,390	\$6.9	\$5.0
BAT 5	\$66.09	NA	8,856,078	\$7.5	NA
<i>Subcategory L</i>					
BAT 2	\$0.30	NA	0	Undefined	NA
BAT 3	\$2.95	\$2.18	320,160	\$9.2	\$6.8
BAT 4	\$4.32	\$3.03	318,194	\$13.6	\$9.5
BAT 5	\$3.85	NA	334,187	\$11.5	NA

Table F-17
Average Cost Effectiveness of Proposed Pollutant Control Options–Total Nutrients
Upper-Bound and Retrofit Costs for Non-small Indirect Dischargers

Regulatory Option	Pretax Annualized Cost (Millions of \$1999)		Total Pounds Removed	Average Cost-Effectiveness (\$1999/Pounds)	
	Upper-Bound	Retrofit		Upper-Bound	Retrofit
<i>Subcategory A through D</i>					
PSES1	\$7.05	NA	907,327	\$7.77	NA
PSES2	\$151.49	NA	1,573,317	\$96.29	NA
PSES3	\$96.25	\$86.42	33,837,795	\$2.84	\$2.55
PSES4	\$120.64	\$105.86	35,215,559	\$3.43	\$3.01
<i>Subcategory E through I</i>					
PSES1	\$18.79	NA	1,997,640	\$9.41	NA
PSES2	\$102.09	NA	1,510,007	\$67.61	NA
PSES3	\$83.68	\$83.25	4,616,635	\$18.13	\$18.03
PSES4	\$110.20	\$109.82	4,603,357	\$23.94	\$23.86
<i>Subcategory J</i>					
PSES1	\$1.33	NA	8,233,864	\$0.16	NA
PSES2	\$23.25	NA	146,708	\$158.51	NA
PSES3	\$27.91	\$23.09	10,194,886	\$2.74	\$2.26
PSES4	\$29.22	\$24.78	10,379,498	\$2.82	\$2.39

Table F-17 (cont.)
Average Cost Effectiveness of Proposed Pollutant Control Options– Total Nutrients
Upper-Bound and Retrofit Costs for Non-small Indirect Dischargers

Regulatory Option	Pretax Annualized Cost (Millions of \$1999)		Total Pounds Removed	Average Cost-Effectiveness (\$1999/Pounds)	
	Upper-Bound	Retrofit		Upper-Bound	Retrofit
<i>Subcategory K</i>					
PSES1	\$10.84	NA	5,468,191	\$1.98	NA
PSES2	\$188.95	NA	2,827,350	\$66.83	NA
PSES3	\$133.01	\$126.00	18,404,976	\$7.23	\$6.85
PSES4	\$136.54	\$131.39	19,217,341	\$7.11	\$6.84
<i>Subcategory L</i>					
PSES1	\$15.26	NA	2,715,456	\$5.62	NA
PSES2	\$105.33	NA	1,893,734	\$55.62	NA
PSES3	\$74.56	\$74.25	5,911,953	\$12.61	\$12.56
PSES4	\$94.11	\$93.89	5,936,600	\$15.85	\$15.82

F.5 SUPPLEMENTAL TABLES

Supplement 1 presents tables containing baseline loads for each subcategory and discharge type. Supplement 2 provides tables detailing estimated pollutant removals for both small and non-small facilities in all subcategories. All supplementary tables present loads or removals in both pounds and pounds equivalent.

F.6 REFERENCES

Engineering News Record. 2000. Construction cost index history, 1911-2000. Engineering News Record. March 27.

LCBP (Lake Champlain Basin Program). 2000. Preliminary Evaluation of Progress Toward Lake Champlain Basin Program Phosphorus Reduction Goals. Prepared by the Lake Champlain Steering Committee. June.

NEWWT (Northeast Wisconsin Waters for Tomorrow, Inc.). 1994. Toward a Cost-Effectiveness Approach to Water Resource Management in the Fox-Wolf River Basin: A First Cut Analysis. Executive Summary. Green Bay, WI.

<http://fwb2k.org/newwttechrept3summary.html>

<http://fwb2k.org/newwtexecsum.html>

<http://fwb2k.org/newwttechrept5.htm>

Randall, C.W. 2000. Personal communication between EPA and Dr. Clifford Randall of Virginia Tech, Blacksburg, VA. August 6.

Randall, C.W., Z. Kisoglu, D. Sen, P. Mitta, and U. Erdal. 1999. Evaluation of Wastewater Treatment Plants for BNR Retrofits using Advances in Technology. Final Report. Virginia Tech, Blacksburg, VA. Submitted to the Point Source Workgroup, Nutrient Removal Subcommittee, Implementation Committee, Chesapeake Bay Program. May.

McCarthy, M, R.C. Dodd, J.P. Tippet, and D. Harding. 1996. Cost-Effectiveness and Targeting of Agricultural BMPs for the Tar-Pamlico Nutrient Trading Program. Presented at Watershed 96 Proceedings, <http://www.epa.gov/owowwtr1/watershed/Proceed/mccarthy.html>

U.S. Environmental Protection Agency. 2001. Economic Analysis of the Proposed Revisions to the National Pollutant Discharge Elimination System Regulation and the Effluent Guidelines for Concentrated Animal Feeding Operations. EPA-821-R-01-001. Washington, DC: U.S. Environmental Protection Agency, Office of Water. January.

U.S. Environmental Protection Agency. 2002. Development Document for the Proposed Effluent Limitations Guidelines and Standards for the Meat Products Industry. EPA-821-B-01-007. Washington, DC: U.S. Environmental Protection Agency, Office of Water.

Wiedeman, A. 1998. Correspondence from Allison Wiedeman, Point Source Coordinator, Chesapeake Bay Program, U.S. Environmental Protection Agency, to Mr. John Adsit, Stewards of Jackson River. May 3.

APPENDIX F

SUPPLEMENT 1

**SUPPORTING DOCUMENTATION FOR
COST EFFECTIVENESS ANALYSIS:
BASELINE POLLUTANT DISCHARGES IN
POUNDS AND POUNDS EQUIVALENT**

**Supplement 1 - Table 1
Baseline Loads for Direct Dischargers: Subcategory A through D**

BASELINE POLLUTANT LOADS			
Pollutants	Pounds/Year	TWF	Pounds Equivalent/Year
All Sizes			
<u>Toxics</u>			
Ammonia as Nitrogen	724,387	1.8E-003	1,326
Carbaryl	242	2.8E+002	67,772
Nitrate/Nitrite	41,401,062	6.2E-005	2,567
Barium	0	2.0E-003	0
Copper	1,703	6.3E-001	1,068
Chromium	26,827	7.6E-002	2,031
Cis-permethrin	2,190	4.5E+000	9,941
Manganese	16,569	7.0E-002	1,166
Molybdenum	1,250	2.0E-001	251
Nickel	3,206	1.1E-001	349
Titanium	367	2.9E-002	11
Trans-permethrin	2,190	4.5E+000	9,941
Vanadium	1,157	6.2E-001	720
Zinc	12,334	4.7E-002	576
Total	42,193,484		97,720
<u>Non Conventionals</u>			
COD	16,342,420		
HEM	14,168,808		
Nitrate/Nitrite	41,401,062		
Total Nitrogen	42,161,727		
<u>Conventionals</u>			
BOD	7,553,876		
HEM	14,168,808		
TSS	7,974,403		
Total	29,697,086		
<u>Nutrients</u>			
Total Phosphorus	6,024,161		
Total Nitrogen	43,021,543		
Total	49,045,705		
<u>Pathogens</u>			
Fecal Coliform	124,309,090		

For the purpose of this analysis, Total Nitrogen as a nutrient is equal to TKN plus Nitrate/Nitrite

**Supplement 1 - Table 2
Baseline Loads for Direct Dischargers: Subcategory E through I**

BASELINE POLLUTANT LOADS			
Pollutants	Pounds/Year	TWF	Pounds Equivalent/Year
All Sizes			
<u>Toxics</u>			
Ammonia as Nitrogen	9,369	1.8E-003	17
Carbaryl	7	2.8E+002	1,876
Nitrate/Nitrite	1,998,924	6.2E-005	124
Barium	163	2.0E-003	0
Copper	65	6.3E-001	41
Chromium	20	7.6E-002	2
Cis-permethrin	58	4.5E+000	262
Manganese	220	7.0E-002	16
Molybdenum	53	2.0E-001	11
Nickel	51	1.1E-001	6
Titanium	10	2.9E-002	0
Trans-permethrin	58	4.5E+000	262
Vanadium	51	6.2E-001	31
Zinc	387	4.7E-002	18
Total	2,009,435		2,665
<u>Non Conventionals</u>			
COD	488,921		
HEM	324,642		
Nitrate/Nitrite	1,998,924		
Total Nitrogen	2,053,680		
<u>Conventionals</u>			
BOD	123,106		
HEM	324,642		
TSS	203,611		
Total	651,359		
<u>Nutrients</u>			
Total Phosphorus	166,188		
Total Nitrogen	2,042,200		
Total	2,208,388		
<u>Pathogens</u>			
Fecal Coliform	378,797,092		

For the purpose of this analysis, Total Nitrogen as a nutrient is equal to TKN plus Nitrate/Nitrite

**Supplement 1 - Table 3
Baseline Loads for Direct Dischargers: Subcategory J**

BASELINE POLLUTANT LOADS			
Pollutants	Pounds/Year	TWF	Pounds Equivalent/Year
All Sizes			
<u>Toxics</u>			
Ammonia as Nitrogen	29,145	1.8E-003	53
Carbaryl	7	2.8E+002	1,847
Nitrate/Nitrite	264,537	6.2E-005	16
Barium	93	2.0E-003	0
Copper	57	6.3E-001	36
Chromium	23	7.6E-002	2
Cis-permethrin	26	4.5E+000	120
Manganese	361	7.0E-002	25
Molybdenum	29	2.0E-001	6
Nickel	80	1.1E-001	9
Titanium	63	2.9E-002	2
Trans-permethrin	26	4.5E+000	120
Vanadium	197	6.2E-001	122
Zinc	576	4.7E-002	27
Total	295,220		2,385
<u>Non Conventionals</u>			
COD	25,990,807		
HEM	1,022,222		
Nitrate/Nitrite	264,537		
Total Nitrogen	623,473		
<u>Conventionals</u>			
BOD	2,569,503		
HEM	1,022,222		
TSS	5,838,573		
Total	9,430,299		
<u>Nutrients</u>			
Total Phosphorus	157,897		
Total Nitrogen	982,283		
Total	1,140,180		
<u>Pathogens</u>			
Fecal Coliform	4,876,874		

For the purpose of this analysis, Total Nitrogen as a nutrient is equal to TKN plus Nitrate/Nitrite

**Supplement 1 - Table 4
Baseline Loads for Direct Dischargers: Subcategory K**

BASELINE POLLUTANT LOADS			
Pollutants	Pounds/Year	TWF	Pounds Equivalent/Year
All Sizes			
<u>Toxics</u>			
Ammonia as Nitrogen	238,604	1.8E-003	437
Carbaryl	219	2.8E+002	61,406
Nitrate/Nitrite	8,023,613	6.2E-005	497
Barium	1,223	2.0E-003	2
Copper	3,743	6.3E-001	2,347
Chromium	0	7.6E-002	0
Cis-permethrin	0	4.5E+000	0
Manganese	3,694	7.0E-002	260
Molybdenum	0	2.0E-001	0
Nickel	555	1.1E-001	60
Titanium	0	2.9E-002	0
Trans-permethrin	0	4.5E+000	0
Vanadium	0	6.2E-001	0
Zinc	18,878	4.7E-002	882
Total	8,290,530		65,891
<u>Non Conventionals</u>			
COD	9,086,617		
HEM	4,872,994		
Nitrate/Nitrite	8,023,613		
Total Nitrogen	8,772,184		
<u>Conventionals</u>			
BOD	1,455,162		
HEM	4,872,994		
TSS	3,125,990		
Total	9,454,146		
<u>Nutrients</u>			
Total Phosphorus	1,187,956		
Total Nitrogen	8,524,631		
Total	9,712,587		
<u>Pathogens</u>			
Fecal Coliform	33,079,247,148		

For the purpose of this analysis, Total Nitrogen as a nutrient is equal to TKN plus Nitrate/Nitrite

**Supplement 1 - Table 5
Baseline Loads for Direct Dischargers: Subcategory L**

BASELINE POLLUTANT LOADS			
Pollutants	Pounds/Year	TWF	Pounds Equivalent/Year
All Sizes			
<u>Toxics</u>			
Ammonia as Nitrogen	4,814	1.8E-003	9
Carbaryl	1	2.8E+002	297
Nitrate/Nitrite	296,136	6.2E-005	18
Barium	121	2.0E-003	0
Copper	87	6.3E-001	55
Chromium	5	7.6E-002	0
Cis-permethrin	0	4.5E+000	0
Manganese	58	7.0E-002	4
Molybdenum	6	2.0E-001	1
Nickel	12	1.1E-001	1
Titanium	1	2.9E-002	0
Trans-permethrin	0	4.5E+000	0
Vanadium	8	6.2E-001	5
Zinc	452	4.7E-002	21
Total	301,702		413
<u>Non Conventionals</u>			
COD	310,025		
HEM	204,682		
Nitrate/Nitrite	296,136		
Total Nitrogen	369,624		
<u>Conventionals</u>			
BOD	40,559		
HEM	204,682		
TSS	82,197		
Total	327,438		
<u>Nutrients</u>			
Total Phosphorus	35,853		
Total Nitrogen	310,294		
Total	346,147		
<u>Pathogens</u>			
Fecal Coliform	1,574,092,398		

For the purpose of this analysis, Total Nitrogen as a nutrient is equal to TKN plus Nitrate/Nitrite

**Supplement 1 - Table 6
Baseline Loads for Indirect Dischargers: Subcategory A through D**

BASELINE POLLUTANT LOADS				
Pollutants	Pounds/Year	TWF	POTW Removal Factor	Pounds Equivalent/Year
All Sizes				
<u>Toxics</u>				
Ammonia as Nitrogen	36,095,938	1.8E-003	6.1E-001	66,056
Carbaryl	852	2.8E+002	7.0E-001	238,621
Nitrate/Nitrite	167,662	6.2E-005	1.0E-001	10
Barium	0	2.0E-003	8.4E-001	0
Copper	1,499	6.3E-001	1.6E-001	940
Chromium	1,182	7.6E-002	2.0E-001	89
Cis-permethrin	370	4.5E+000	5.0E-001	1,680
Manganese	67,191	7.0E-002	6.4E-001	4,730
Molybdenum	1,728	2.0E-001	8.1E-001	347
Nickel	1,038	1.1E-001	4.9E-001	113
Titanium	52	2.9E-002	8.2E-002	2
Trans-permethrin	365	4.5E+000	5.0E-001	1,658
Vanadium	302	6.2E-001	9.0E-001	188
Zinc	8,327	4.7E-002	2.1E-001	389
Total	36,346,507			314,824
 <u>Non conventional</u>				
COD	54,891,450	NA	1.9E-001	
 <u>Conventionals</u>				
BOD	12,609,509	NA	1.1E-001	
HEM	1,814,822	NA	1.4E-001	
TSS	6,588,443	NA	1.0E-001	
Total	21,012,774			
 <u>Nutrients</u>				
Total Phosphorus	2,736,275	NA	4.3E-001	
Total Nitrogen	14,134,388	NA	4.3E-001	POTW Removal Factor for TKN
			1.0E-001	POTW Removal Factor for Nitrate/Nitrite
Total	16,870,663			
 <u>Pathogens</u>				
Fecal Coliform	3,426,583,069	NA	4.0E-003	

Baseline loads in Pounds/Year have been adjusted by the POTW factor.

For the purpose of this analysis, Total Nitrogen as a nutrient is equal to TKN plus Nitrate/Nitrite

Supplement 1 - Table 7
Baseline Loads for Indirect Dischargers: Subcategory E through I

BASELINE POLLUTANT LOADS				
Pollutants	Pounds/Year	TWF	POTW Removal Factor	Pounds Equivalent/Year
All Sizes				
<u>Toxics</u>				
Ammonia as Nitrogen	2,905,087	1.8E-003	6.1E-001	5,316
Carbaryl	260	2.8E+002	7.0E-001	72,847
Nitrate/Nitrite	39,825	6.2E-005	1.0E-001	2
Barium	2,269	2.0E-003	8.4E-001	5
Copper	904	6.3E-001	1.6E-001	567
Chromium	305	7.6E-002	2.0E-001	23
Cis-permethrin	153	4.5E+000	5.0E-001	693
Manganese	3,453	7.0E-002	6.4E-001	243
Molybdenum	1,038	2.0E-001	8.1E-001	209
Nickel	609	1.1E-001	4.9E-001	66
Titanium	28	2.9E-002	8.2E-002	1
Trans-permethrin	85	4.5E+000	5.0E-001	385
Vanadium	147	6.2E-001	9.0E-001	91
Zinc	3,605	4.7E-002	2.1E-001	168
Total	2,957,767			80,617
 <u>Non conventional</u>				
COD	28,993,490	NA	1.9E-001	
 <u>Conventionals</u>				
BOD	12,540,877	NA	1.1E-001	
HEM	919,126	NA	1.4E-001	
TSS	3,178,872	NA	1.0E-001	
Total	16,638,874			
 <u>Nutrients</u>				
Total Phosphorus	2,202,891	NA	4.3E-001	
Total Nitrogen	1,233,541	NA	4.3E-001	POTW Removal Factor for TKN
			1.0E-001	POTW Removal Factor for Nitrate/Nitrite
Total	3,436,431			
 <u>Pathogens</u>				
Fecal Coliform	1,176,873,655	NA	4.0E-003	

Baseline loads in Pounds/Year have been adjusted by the POTW factor.

For the purpose of this analysis, Total Nitrogen as a nutrient is equal to TKN plus Nitrate/Nitrite

**Supplement 1 - Table 8
Baseline Loads for Indirect Dischargers: Subcategory J**

BASELINE POLLUTANT LOADS				
Pollutants	Pounds/Year	TWF	POTW Removal Factor	Pounds Equivalent/Year
All Sizes				
<u>Toxics</u>				
Ammonia as Nitrogen	1,050,364	1.8E-003	6.1E-001	1,922
Carbaryl	47	2.8E+002	7.0E-001	13,192
Nitrate/Nitrite	32,168	6.2E-005	1.0E-001	2
Barium	0	2.0E-003	8.4E-001	0
Copper	89	6.3E-001	1.6E-001	56
Chromium	66	7.6E-002	2.0E-001	5
Cis-permethrin	45	4.5E+000	5.0E-001	202
Manganese	1,950	7.0E-002	6.4E-001	137
Molybdenum	115	2.0E-001	8.1E-001	23
Nickel	46	1.1E-001	4.9E-001	5
Titanium	15	2.9E-002	8.2E-002	0
Trans-permethrin	44	4.5E+000	5.0E-001	200
Vanadium	423	6.2E-001	9.0E-001	263
Zinc	659	4.7E-002	2.1E-001	31
Total	1,086,031			16,039
<u>Non conventional</u>				
COD	11,617,728	NA	1.9E-001	
<u>Conventionals</u>				
BOD	3,365,974	NA	1.1E-001	
HEM	435,945	NA	1.4E-001	
TSS	1,410,766	NA	1.0E-001	
Total	5,212,685			
<u>Nutrients</u>				
Total Phosphorus	300,419	NA	4.3E-001	
Total Nitrogen	13,664,016	NA	4.3E-001	POTW Removal Factor for TKN
			1.0E-001	POTW Removal Factor for Nitrate/Nitrite
Total	13,964,436			
<u>Pathogens</u>				
Fecal Coliform	267,187,601	NA	4.0E-003	

Baseline loads in Pounds/Year have been adjusted by the POTW factor.

For the purpose of this analysis, Total Nitrogen as a nutrient is equal to TKN plus Nitrate/Nitrite

**Supplement 1 - Table 9
Baseline Loads for Indirect Dischargers: Subcategory K**

BASELINE POLLUTANT LOADS				
Pollutants	Pounds/Year	TWF	POTW Removal Factor	Pounds Equivalent/Year
All Sizes				
<u>Toxics</u>				
Ammonia as Nitrogen	2,440,306	1.8E-003	6.1E-001	4,466
Carbaryl	1,417	2.8E+002	7.0E-001	396,892
Nitrate/Nitrite	207,290	6.2E-005	1.0E-001	13
Barium	4,783	2.0E-003	8.4E-001	10
Copper	1,468	6.3E-001	1.6E-001	921
Chromium	0	7.6E-002	2.0E-001	0
Cis-permethrin	0	4.5E+000	5.0E-001	0
Manganese	26,642	7.0E-002	6.4E-001	1,876
Molybdenum	0	2.0E-001	8.1E-001	0
Nickel	2	1.1E-001	4.9E-001	0
Titanium	0	2.9E-002	8.2E-002	0
Trans-permethrin	0	4.5E+000	5.0E-001	0
Vanadium	0	6.2E-001	9.0E-001	0
Zinc	8,235	4.7E-002	2.1E-001	385
Total	2,690,143			404,561
<u>Non conventional</u>				
COD	45,841,533	NA	1.9E-001	
<u>Conventionals</u>				
BOD	19,204,367	NA	1.1E-001	
HEM	4,106,242	NA	1.4E-001	
TSS	26,522,648	NA	1.0E-001	
Total	49,833,257			
<u>Nutrients</u>				
Total Phosphorus	3,101,772	NA	4.3E-001	
Total Nitrogen	9,094,488	NA	4.3E-001	POTW Removal Factor for TKN
			1.0E-001	POTW Removal Factor for Nitrate/Nitrite
Total	12,196,260			
<u>Pathogens</u>				
Fecal Coliform	6,457,186,197	NA	4.0E-003	

Baseline loads in Pounds/Year have been adjusted by the POTW factor.

For the purpose of this analysis, Total Nitrogen as a nutrient is equal to TKN plus Nitrate/Nitrite

Supplement 1 - Table 10
Baseline Loads for Indirect Dischargers: Subcategory L

BASELINE POLLUTANT LOADS				
Pollutants	Pounds/Year	TWF	POTW Removal Factor	Pounds Equivalent/Year
All Sizes				
<u>Toxics</u>				
Ammonia as Nitrogen	1,132,489	1.8E-003	6.1E-001	2,072
Carbaryl	176	2.8E+002	7.0E-001	49,374
Nitrate/Nitrite	17,555	6.2E-005	1.0E-001	1
Barium	2,799	2.0E-003	8.4E-001	6
Copper	359	6.3E-001	1.6E-001	225
Chromium	46	7.6E-002	2.0E-001	4
Cis-permethrin	44	4.5E+000	5.0E-001	198
Manganese	1,895	7.0E-002	6.4E-001	133
Molybdenum	294	2.0E-001	8.1E-001	59
Nickel	180	1.1E-001	4.9E-001	20
Titanium	8	2.9E-002	8.2E-002	0
Trans-permethrin	42	4.5E+000	5.0E-001	190
Vanadium	40	6.2E-001	9.0E-001	25
Zinc	6,744	4.7E-002	2.1E-001	315
Total	1,162,670			52,621
<u>Non conventional</u>				
COD	40,029,588	NA	1.9E-001	
<u>Conventionals</u>				
BOD	9,781,631	NA	1.1E-001	
HEM	1,652,650	NA	1.4E-001	
TSS	10,279,123	NA	1.0E-001	
Total	21,713,404			
<u>Nutrients</u>				
Total Phosphorus	2,304,870	NA	4.3E-001	
Total Nitrogen	2,207,554	NA	4.3E-001	POTW Removal Factor for TKN
			1.0E-001	POTW Removal Factor for Nitrate/Nitrite
Total	4,512,424			
<u>Pathogens</u>				
Fecal Coliform	638,395,367	NA	4.0E-003	

Baseline loads in Pounds/Year have been adjusted by the POTW factor.

For the purpose of this analysis, Total Nitrogen as a nutrient is equal to TKN plus Nitrate/Nitrite

APPENDIX F

SUPPLEMENT 2

**SUPPORTING DOCUMENTATION FOR
COST EFFECTIVENESS ANALYSIS:
POLLUTANT REMOVALS BY OPTION IN
POUNDS AND POUNDS EQUIVALENT**

**Supplement 2 - Table 1
Pollutant Removals - By Option and Size
Subcategory A through D - Direct Dischargers**

Pollutants	Removals (Pounds/Year)				TWF	Removals (Pounds Equivalent/Year)			
	BAT1	BAT2	BAT3	BAT4		BAT1	BAT2	BAT3	BAT4
SMALL FACILITY REMOVALS									
<u>Toxics</u>									
Ammonia as Nitrogen	361	361	0	NA	1.8E-003	0.7	0.7	0.0	NA
Carbaryl	0	0	0	NA	2.8E+002	36.8	36.8	36.8	NA
Nitrate/Nitrite	7,471	7,471	22,310	NA	6.2E-005	0.5	0.5	1.4	NA
Barium	0	0	0	NA	2.0E-003	0.0	0.0	0.0	NA
Copper	1	1	1	NA	6.3E-001	0.3	0.3	0.4	NA
Chromium	33	33	33	NA	7.6E-002	2.5	2.5	2.5	NA
Cis-permethrin	1	1	1	NA	4.5E+000	6.0	6.0	6.0	NA
Manganese	5	5	1	NA	7.0E-002	0.3	0.3	0.1	NA
Molybdenum	0	0	0	NA	2.0E-001	0.0	0.0	0.0	NA
Nickel	1	1	0	NA	1.1E-001	0.1	0.1	0.0	NA
Titanium	0	0	0	NA	2.9E-002	0.0	0.0	0.0	NA
Trans-permethrin	1	1	1	NA	4.5E+000	6.0	6.0	6.0	NA
Vanadium	0	0	0	NA	6.2E-001	0.1	0.1	0.2	NA
Zinc	2	2	5	NA	4.7E-002	0.1	0.1	0.2	NA
Total	7,878	7,878	22,353	NA		54	54	54	NA
<u>Cost Reasonableness</u>									
Pollutant	<u>NA</u>	<u>HEM</u>	<u>Nitrate/Nitrite</u>	<u>Nitrate/Nitrite</u>					
	0	5,889	22,310	NA					
<u>Conventionals</u>									
BOD	4,449	4,449	4,426	NA					
HEM	5,889	5,889	5,618	NA					
TSS	4,690	4,690	5,641	NA					
Total	15,028	15,028	15,685	NA					
<u>Nutrients</u>									
Total Nitrogen	6,808	0	21,871	NA					
Total Phosphorus	1,122	1,122	2,525	NA					
Total	7,930	1,122	24,395	NA					

Note: Numbers may not sum due to rounding

Supplement 2 - Table 1 (continued)
Pollutant Removals - By Option and Size
Subcategory A through D - Direct Dischargers

<u>Pollutants</u>	<u>Removals (Pounds/Year)</u>				<u>TWF</u>	<u>Removals (Pounds Equivalent/Year)</u>			
	<u>BAT1</u>	<u>BAT2</u>	<u>BAT3</u>	<u>BAT4</u>		<u>BAT1</u>	<u>BAT2</u>	<u>BAT3</u>	<u>BAT4</u>
NONSMALL FACILITY REMOVALS									
<u>Toxics</u>									
Ammonia as Nitrogen	0	543,439	0	0	1.8E-003	0	994.5	0.0	0.0
Carbaryl	0	242	242	242	2.8E+002	0	67,735.3	67,735.3	67,735.3
Nitrate/Nitrite	0	13,946,089	38,701,846	41,013,454	6.2E-005	0	864.7	2,399.5	2,542.8
Barium	0	0	0	0	2.0E-003	0	0.0	0.0	0.0
Copper	0	1,015	1,234	1,395	6.3E-001	0	636.3	773.7	874.8
Chromium	0	26,558	26,062	26,085	7.6E-002	0	2,010.4	1,972.9	1,974.6
Cis-permethrin	0	2,188	2,188	2,188	4.5E+000	0	9,935.3	9,935.3	9,935.3
Manganese	0	9,941	1,035	1,035	7.0E-002	0	699.8	72.8	72.8
Molybdenum	0	212	32	513	2.0E-001	0	42.7	6.5	103.1
Nickel	0	2,765	0	0	1.1E-001	0	301.4	0.0	0.0
Titanium	0	130	0	0	2.9E-002	0	3.8	0.0	0.0
Trans-permethrin	0	2,188	2,188	2,188	4.5E+000	0	9,935.3	9,935.3	9,935.3
Vanadium	0	382	700	965	6.2E-001	0	237.4	435.5	600.5
Zinc	0	4,049	9,000	9,000	4.7E-002	0	189.1	420.3	420.3
Total	0	14,539,199	38,744,528	41,057,066		0	93,586	93,687	94,195
<u>Cost Reasonableness</u>									
Pollutant	<u>NA</u>	<u>HEM</u>	<u>Nitrate/Nitrite</u>	<u>Nitrate/Nitrite</u>					
	0	12,338,109	38,701,846	41,013,454					
<u>Conventionals</u>									
BOD	0	5,934,504	5,878,682	5,878,682					
HEM	0	12,338,109	11,782,383	13,711,676					
TSS	0	4,238,002	6,038,219	6,038,219					
Total	0	22,510,616	23,699,283	25,628,576					
<u>Nutrients</u>									
Total Nitrogen	0	0	38,192,320	40,290,551					
Total Phosphorus	0	1,972,012	4,626,000	4,626,000					
Total	0	1,972,012	42,818,320	44,916,551					

Note: Numbers may not sum due to rounding

Supplement 2 - Table 2
Pollutant Removals - By Option and Size
Subcategory E through I - Direct Dischargers

Pollutants	Removals (Pounds/Year)				TWF	Removals (Pounds Equivalent/Year)			
	BAT1	BAT2	BAT3	BAT4		BAT1	BAT2	BAT3	BAT4
SMALL FACILITY REMOVALS									
<u>Toxics</u>									
Ammonia as Nitrogen	10	10	8	NA	1.8E-003	0.0	0.0	0.0	NA
Carbaryl	0	0	0	NA	2.8E+002	1.9	1.9	1.9	NA
Nitrate/Nitrite	11,832	11,832	11,857	NA	6.2E-005	0.7	0.7	0.7	NA
Barium	1	1	1	NA	2.0E-003	0.0	0.0	0.0	NA
Copper	0	0	0	NA	6.3E-001	0.1	0.1	0.1	NA
Chromium	0	0	0	NA	7.6E-002	0.0	0.0	0.0	NA
Cis-permethrin	0	0	0	NA	4.5E+000	0.0	0.0	0.0	NA
Manganese	0	0	0	NA	7.0E-002	0.0	0.0	0.0	NA
Molybdenum	0	0	0	NA	2.0E-001	0.0	0.0	0.0	NA
Nickel	0	0	0	NA	1.1E-001	0.0	0.0	0.0	NA
Titanium	0	0	0	NA	2.9E-002	0.0	0.0	0.0	NA
Trans-permethrin	0	0	0	NA	4.5E+000	0.0	0.0	0.0	NA
Vanadium	0	0	0	NA	6.2E-001	0.1	0.1	0.1	NA
Zinc	0	0	1	NA	4.7E-002	0.0	0.0	0.0	NA
Total	11,844	11,844	11,868	NA		3	3	3	NA
<u>Cost Reasonableness</u>									
Pollutant	<u>NA</u>	<u>HEM</u>	<u>Total Nitrogen</u>	<u>Total Nitrogen</u>					
	0	411	12,059	NA					
<u>Conventionals</u>									
BOD	144	144	136	NA					
HEM	411	411	468	NA					
TSS	797	797	889	NA					
Total	1,352	1,352	1,493	NA					
<u>Nutrients</u>									
Total Nitrogen	11,571	0	12,059	NA					
Total Phosphorus	0	0	293	NA					
Total	11,571	0	12,352	NA					

Note: Numbers may not sum due to rounding

Supplement 2 - Table 2 (continued)
Pollutant Removals - By Option and Size
Subcategory E through I - Direct Dischargers

Pollutants	Removals (Pounds/Year)				TWF	Removals (Pounds Equivalent/Year)			
	BAT1	BAT2	BAT3	BAT4		BAT1	BAT2	BAT3	BAT4
NONSMALL FACILITY REMOVALS									
<u>Toxics</u>									
Ammonia as Nitrogen	0	4,264	3,580	3,574	1.8E-003	0	7.8	6.6	6.5
Carbaryl	0	7	7	7	2.8E+002	0	1,874.5	1,874.5	1,874.5
Nitrate/Nitrite	0	1,972,558	1,976,713	1,987,005	6.2E-005	0	122.3	122.6	123.2
Barium	0	143	154	140	2.0E-003	0	0.3	0.3	0.3
Copper	0	41	58	56	6.3E-001	0	25.8	36.1	35.2
Chromium	0	11	7	9	7.6E-002	0	0.8	0.5	0.7
Cis-permethrin	0	58	58	58	4.5E+000	0	261.5	261.5	261.5
Manganese	0	188	147	135	7.0E-002	0	13.2	10.4	9.5
Molybdenum	0	18	5	5	2.0E-001	0	3.6	1.0	1.0
Nickel	0	42	20	20	1.1E-001	0	4.6	2.2	2.2
Titanium	0	6	4	4	2.9E-002	0	0.2	0.1	0.1
Trans-permethrin	0	58	58	58	4.5E+000	0	261.5	261.5	261.5
Vanadium	0	42	46	46	6.2E-001	0	26.1	28.9	28.6
Zinc	0	150	259	223	4.7E-002	0	7.0	12.1	10.4
Total	0	1,977,584	1,981,114	1,991,340		0	2,609	2,618	2,615
<u>Cost Reasonableness</u>									
Pollutant	<u>NA</u>	<u>HEM</u>	<u>Total Nitrogen</u>	<u>Total Nitrogen</u>					
	0	254,367	2,010,906	2,023,173					
<u>Conventionals</u>									
BOD	0	80,308	77,481	71,550					
HEM	0	254,367	270,976	318,760					
TSS	0	126,020	154,729	154,729					
Total	0	460,695	503,187	545,040					
<u>Nutrients</u>									
Total Nitrogen	0	0	2,010,906	2,023,173					
Total Phosphorus	0	35,700	104,733	97,026					
Total	0	35,700	2,115,639	2,120,199					

Note: Numbers may not sum due to rounding

**Supplement 2 - Table 3
Pollutant Removals - By Option and Size
Subcategory J - Direct Dischargers**

Pollutants	Removals (Pounds/Year)				TWF	Removals (Pounds Equivalent/Year)			
	BAT1	BAT2	BAT3	BAT4		BAT1	BAT2	BAT3	BAT4
SMALL FACILITY REMOVALS									
<u>Toxics</u>									
Ammonia as Nitrogen	3,106	3,106	2,933	NA	1.8E-003	5.7	5.7	5.4	NA
Carbaryl	2	2	2	NA	2.8E+002	511.7	511.7	511.7	NA
Nitrate/Nitrite	49,073	49,073	56,036	NA	6.2E-005	3.0	3.0	3.5	NA
Barium	16	16	21	NA	2.0E-003	0.0	0.0	0.0	NA
Copper	2	2	11	NA	6.3E-001	1.1	1.1	7.1	NA
Chromium	0	0	0	NA	7.6E-002	0.0	0.0	0.0	NA
Cis-permethrin	7	7	7	NA	4.5E+000	33.2	33.2	33.2	NA
Manganese	78	78	67	NA	7.0E-002	5.5	5.5	4.7	NA
Molybdenum	2	2	2	NA	2.0E-001	0.5	0.5	0.4	NA
Nickel	17	17	14	NA	1.1E-001	1.8	1.8	1.5	NA
Titanium	0	0	0	NA	2.9E-002	0.0	0.0	0.0	NA
Trans-permethrin	7	7	7	NA	4.5E+000	33.2	33.2	33.2	NA
Vanadium	0	0	30	NA	6.2E-001	0.0	0.0	18.4	NA
Zinc	0	0	105	NA	4.7E-002	0.0	0.0	4.9	NA
Total	52,310	52,310	59,236	NA		596	596	624	NA
<u>Cost Reasonableness</u>									
Pollutant	<u>NA</u>	<u>COD</u>	<u>COD</u>	<u>COD</u>					
	0	7,026,665	7,024,152	NA					
<u>Conventionals</u>									
BOD	703,031	703,031	702,512	NA					
HEM	0	0	67,557	NA					
TSS	1,578,784	1,578,784	1,607,307	NA					
Total	2,281,815	2,281,815	2,377,377	NA					
<u>Nutrients</u>									
Total Nitrogen	0	0	147,206	NA					
Total Phosphorus	34,027	34,027	39,922	NA					
Total	34,027	34,027	187,128	NA					

Note: Numbers may not sum due to rounding

Supplement 2 - Table 3 (continued)
Pollutant Removals - By Option and Size
Subcategory J - Direct Dischargers

Pollutants	Removals (Pounds/Year)				TWF	Removals (Pounds Equivalent/Year)			
	BAT1	BAT2	BAT3	BAT4		BAT1	BAT2	BAT3	BAT4
NONSMALL FACILITY REMOVALS									
<u>Toxics</u>									
Ammonia as Nitrogen	0	7,069	6,580	6,498	1.8E-003	0	12.9	12.0	11.9
Carbaryl	0	5	5	5	2.8E+002	0	1,335.4	1,335.4	1,335.4
Nitrate/Nitrite	0	123,011	142,637	182,437	6.2E-005	0	7.6	8.8	11.3
Barium	0	41	55	30	2.0E-003	0	0.1	0.1	0.1
Copper	0	2	29	9	6.3E-001	0	1.0	18.1	5.7
Chromium	0	0	0	5	7.6E-002	0	0.0	0.0	0.4
Cis-permethrin	0	19	19	19	4.5E+000	0	86.6	86.6	86.6
Manganese	0	198	169	0	7.0E-002	0	13.9	11.9	0.0
Molybdenum	0	5	4	3	2.0E-001	0	1.0	0.8	0.6
Nickel	0	42	34	13	1.1E-001	0	4.6	3.7	1.4
Titanium	0	0	0	0	2.9E-002	0	0.0	0.0	0.0
Trans-permethrin	0	19	19	19	4.5E+000	0	86.6	86.6	86.6
Vanadium	0	0	72	10	6.2E-001	0	0.0	44.7	6.2
Zinc	0	0	262	142	4.7E-002	0	0.0	12.3	6.6
Total	0	130,410	149,885	189,190		0	1,550	1,621	1,553
<u>Cost Reasonableness</u>									
Pollutant	<u>NA</u>	<u>COD</u>	<u>COD</u>	<u>COD</u>					
	0	18,301,253	18,294,172	18,146,476					
<u>Conventionals</u>									
BOD	0	1,832,864	1,831,400	1,790,542					
HEM	0	0	131,286	679,074					
TSS	0	4,112,078	4,192,471	4,150,078					
Total	0	5,944,943	6,155,157	6,619,694					
<u>Nutrients</u>									
Total Nitrogen	0	0	378,836	433,771					
Total Phosphorus	0	86,772	103,388	97,425					
Total	0	86,772	482,224	531,196					

Note: Numbers may not sum due to rounding

**Supplement 2 - Table 4
Pollutant Removals - By Option and Size
Subcategory K - Direct Dischargers**

<u>Pollutants</u>	<u>Removals (Pounds/Year)</u>					<u>TWF</u>	<u>Removals (Pounds Equivalent/Year)</u>				
	<u>BAT1</u>	<u>BAT2</u>	<u>BAT3</u>	<u>BAT4</u>	<u>BAT5</u>		<u>BAT1</u>	<u>BAT2</u>	<u>BAT3</u>	<u>BAT4</u>	<u>BAT5</u>
SMALL FACILITY REMOVALS											
<u>Toxics</u>											
Ammonia as Nitrogen	NA	NA	NA	NA	NA	1.8E-003	NA	NA	NA	NA	NA
Carbaryl	NA	NA	NA	NA	NA	2.8E+002	NA	NA	NA	NA	NA
Nitrate/Nitrite	NA	NA	NA	NA	NA	6.2E-005	NA	NA	NA	NA	NA
Barium	NA	NA	NA	NA	NA	2.0E-003	NA	NA	NA	NA	NA
Copper	NA	NA	NA	NA	NA	6.3E-001	NA	NA	NA	NA	NA
Chromium	NA	NA	NA	NA	NA	7.6E-002	NA	NA	NA	NA	NA
Cis-permethrin	NA	NA	NA	NA	NA	4.5E+000	NA	NA	NA	NA	NA
Manganese	NA	NA	NA	NA	NA	7.0E-002	NA	NA	NA	NA	NA
Molybdenum	NA	NA	NA	NA	NA	2.0E-001	NA	NA	NA	NA	NA
Nickel	NA	NA	NA	NA	NA	1.1E-001	NA	NA	NA	NA	NA
Titanium	NA	NA	NA	NA	NA	2.9E-002	NA	NA	NA	NA	NA
Trans-permethrin	NA	NA	NA	NA	NA	4.5E+000	NA	NA	NA	NA	NA
Vanadium	NA	NA	NA	NA	NA	6.2E-001	NA	NA	NA	NA	NA
Zinc	NA	NA	NA	NA	NA	4.7E-002	NA	NA	NA	NA	NA
Total	NA	NA	NA	NA	NA		NA	NA	NA	NA	NA
<u>Cost Reasonableness</u>											
<u>Pollutant</u>	<u>NA</u>	<u>COD</u>	<u>Total Nitrogen</u>	<u>Total Nitrogen</u>	<u>Total Nitrogen</u>						
	NA	NA	NA	NA	NA						
<u>Conventionals</u>											
BOD	NA	NA	NA	NA	NA						
HEM	NA	NA	NA	NA	NA						
TSS	NA	NA	NA	NA	NA						
Total	NA	NA	NA	NA	NA						
<u>Nutrients</u>											
Total Nitrogen	NA	NA	NA	NA	NA						
Total Phosphorus	NA	NA	NA	NA	NA						
Total	NA	NA	NA	NA	NA						

Note: Numbers may not sum due to rounding

There are no small direct discharging facilities in Subcategory K

Supplement 2 - Table 4 (continued)
Pollutant Removals - By Option and Size
Subcategory K - Direct Dischargers

Pollutants	Removals (Pounds/Year)					TWF	Removals (Pounds Equivalent/Year)				
	BAT1	BAT2	BAT3	BAT4	BAT5		BAT1	BAT2	BAT3	BAT4	BAT5
NONSMALL FACILITY REMOVALS											
<u>Toxics</u>											
Ammonia as Nitrogen	0	150,329	150,329	158,189	158,548	1.8E-003	0	275.1	275.1	289.5	290.1
Carbaryl	0	219	219	219	219	2.8E+002	0	61,405.7	61,405.7	61,405.7	61,405.7
Nitrate/Nitrite	0	2,351,094	7,147,589	7,832,644	7,805,798	6.2E-005	0	145.8	443.2	485.6	484.0
Barium	0	149	1,053	0	0	2.0E-003	0	0.3	2.1	0.0	0.0
Copper	0	1,935	2,141	2,606	3,494	6.3E-001	0	1,213.4	1,342.2	1,634.2	2,190.5
Chromium	0	0	0	0	0	7.6E-002	0	0.0	0.0	0.0	0.0
Cis-permethrin	0	0	0	0	0	4.5E+000	0	0.0	0.0	0.0	0.0
Manganese	0	1,889	1,889	0	0	7.0E-002	0	133.0	133.0	0.0	0.0
Molybdenum	0	0	0	0	0	2.0E-001	0	0.0	0.0	0.0	0.0
Nickel	0	174	174	0	1	1.1E-001	0	18.9	18.9	0.0	0.1
Titanium	0	0	0	0	0	2.9E-002	0	0.0	0.0	0.0	0.0
Trans-permethrin	0	0	0	0	0	4.5E+000	0	0.0	0.0	0.0	0.0
Vanadium	0	0	0	0	0	6.2E-001	0	0.0	0.0	0.0	0.0
Zinc	0	0	10,140	4,580	17,095	4.7E-002	0	0.0	473.5	213.9	798.4
Total	0	2,505,789	7,313,534	7,998,238	7,985,156		0	63,192	64,094	64,029	65,169
<u>Cost Reasonableness</u>											
Pollutant	<u>NA</u>	<u>COD</u>	<u>Total Nitrogen</u>	<u>Total Nitrogen</u>	<u>Total Nitrogen</u>						
	0	1,633,180	7,320,643	8,101,809	8,032,409						
<u>Conventionals</u>											
BOD	0	941,505	948,115	0	520,609						
HEM	0	0	357,402	3,329,295	3,319,882						
TSS	0	298,472	1,138,254	616,948	948,051						
Total	0	1,239,977	2,443,771	3,946,243	4,788,542						
<u>Nutrients</u>											
Total Nitrogen	0	0	7,320,643	8,101,809	8,032,409						
Total Phosphorus	0	809,833	1,051,184	768,582	823,669						
Total	0	809,833	8,371,827	8,870,390	8,856,078						

Note: Numbers may not sum due to rounding

**Supplement 2 - Table 5
Pollutant Removals - By Option and Size
Subcategory L - Direct Dischargers**

Pollutants	Removals (Pounds/Year)					TWF	Removals (Pounds Equivalent/Year)				
	BAT1	BAT2	BAT3	BAT4	BAT5		BAT1	BAT2	BAT3	BAT4	BAT5
SMALL FACILITY REMOVALS											
<u>Toxics</u>											
Ammonia as Nitrogen	2	2	2	NA	NA	1.8E-003	0.0	0.0	0.0	NA	NA
Carbaryl	0	0	0	NA	NA	2.8E+002	1.3	1.3	1.3	NA	NA
Nitrate/Nitrite	778	778	780	NA	NA	6.2E-005	0.0	0.0	0.0	NA	NA
Barium	0	0	0	NA	NA	2.0E-003	0.0	0.0	0.0	NA	NA
Copper	0	0	0	NA	NA	6.3E-001	0.0	0.0	0.0	NA	NA
Chromium	0	0	0	NA	NA	7.6E-002	0.0	0.0	0.0	NA	NA
Cis-permethrin	0	0	0	NA	NA	4.5E+000	0.0	0.0	0.0	NA	NA
Manganese	0	0	0	NA	NA	7.0E-002	0.0	0.0	0.0	NA	NA
Molybdenum	0	0	0	NA	NA	2.0E-001	0.0	0.0	0.0	NA	NA
Nickel	0	0	0	NA	NA	1.1E-001	0.0	0.0	0.0	NA	NA
Titanium	0	0	0	NA	NA	2.9E-002	0.0	0.0	0.0	NA	NA
Trans-permethrin	0	0	0	NA	NA	4.5E+000	0.0	0.0	0.0	NA	NA
Vanadium	0	0	0	NA	NA	6.2E-001	0.0	0.0	0.0	NA	NA
Zinc	0	0	0	NA	NA	4.7E-002	0.0	0.0	0.0	NA	NA
Total	780	780	783	NA	NA		1	1	1	NA	NA
<u>Cost Reasonableness</u>											
Pollutant	<u>NA</u>	<u>HEM</u>	<u>Total Nitrogen</u>	<u>Total Nitrogen</u>	<u>Total Nitrogen</u>						
	0	83	802	NA	NA						
<u>Conventionals</u>											
BOD	19	19	18	NA	NA						
HEM	83	83	101	NA	NA						
TSS	0	0	0	NA	NA						
Total	102	102	119	NA	NA						
<u>Nutrients</u>											
Total Nitrogen	574	0	802	NA	NA						
Total Phosphorus	0	0	24	NA	NA						
Total	574	0	826	NA	NA						

Note: Numbers may not sum due to rounding

Supplement 2 - Table 5 (continued)
Pollutant Removals - By Option and Size
Subcategory L - Direct Dischargers

Pollutants	Removals (Pounds/Year)					TWF	Removals (Pounds Equivalent/Year)				
	BAT1	BAT2	BAT3	BAT4	BAT5		BAT1	BAT2	BAT3	BAT4	BAT5
NONSMALL FACILITY REMOVALS											
<u>Toxics</u>											
Ammonia as Nitrogen	0	1,870	1,854	1,833	2,413	1.8E-003	0	3.4	3.4	3.4	4.4
Carbaryl	0	1	1	1	1	2.8E+002	0	296.2	296.2	296.2	296.2
Nitrate/Nitrite	0	290,623	291,982	294,966	294,912	6.2E-005	0	18.0	18.1	18.3	18.3
Barium	0	92	100	89	104	2.0E-003	0	0.2	0.2	0.2	0.2
Copper	0	76	84	78	85	6.3E-001	0	47.9	52.5	48.8	53.6
Chromium	0	0	0	0	5	7.6E-002	0	0.0	0.0	0.0	0.4
Cis-permethrin	0	0	0	0	0	4.5E+000	0	0.0	0.0	0.0	0.0
Manganese	0	44	43	0	11	7.0E-002	0	3.1	3.0	0.0	0.8
Molybdenum	0	0	0	0	6	2.0E-001	0	0.0	0.0	0.0	1.1
Nickel	0	0	0	0	3	1.1E-001	0	0.0	0.0	0.0	0.3
Titanium	0	0	0	0	1	2.9E-002	0	0.0	0.0	0.0	0.0
Trans-permethrin	0	0	0	0	0	4.5E+000	0	0.0	0.0	0.0	0.0
Vanadium	0	7	8	7	8	6.2E-001	0	4.3	4.7	4.5	5.1
Zinc	0	0	97	0	383	4.7E-002	0	0.0	4.5	0.0	17.9
Total	0	292,713	294,169	296,974	297,932		0	373	383	371	398
<u>Cost Reasonableness</u>											
Pollutant	<u>NA</u>	<u>HEM</u>	<u>Total Nitrogen</u>	<u>Total Nitrogen</u>	<u>Total Nitrogen</u>						
	0	92,061	307,076	318,194	321,809						
<u>Conventionals</u>											
BOD	0	16,754	16,629	0	8,941						
HEM	0	92,061	118,890	196,074	197,453						
TSS	0	0	0	0	24,029						
Total	0	108,816	135,519	196,074	230,422						
<u>Nutrients</u>											
Total Nitrogen	0	0	307,076	318,194	321,809						
Total Phosphorus	0	0	13,084	0	12,378						
Total	0	0	320,160	318,194	334,187						

Note: Numbers may not sum due to rounding

**Supplement 2 - Table 6
Pollutant Removals - By Option and Size
Subcategory A through D - Indirect Dischargers**

Pollutants	Removals (Pounds/Year)				TWF	POTW Removal Factor	Removals (Pounds Equivalent/Year)			
	PSES1	PSES2	PSES3	PSES4			PSES1	PSES2	PSES3	PSES4
SMALL FACILITY REMOVALS										
<u>Toxics</u>										
Ammonia as Nitrogen	0	412,497	400,889	403,474	1.8E-003	61.1%	0.0	460.9	448.0	450.8
Carbaryl	14	14	14	14	2.8E+002	70.0%	2,775.8	2,775.8	2,775.8	2,775.8
Nitrate/Nitrite	10,446	4,686	8,967	9,299	6.2E-005	10.0%	0.1	0.0	0.1	0.1
Barium	0	0	0	0	2.0E-003	84.0%	0.0	0.0	0.0	0.0
Copper	99	121	120	122	6.3E-001	15.8%	9.8	12.0	11.9	12.0
Chromium	26	40	36	36	7.6E-002	19.7%	0.4	0.6	0.5	0.5
Cis-permethrin	5	5	5	5	4.5E+000	50.0%	11.8	11.8	11.8	11.8
Manganese	0	713	650	650	7.0E-002	64.5%	0.0	32.4	29.5	29.5
Molybdenum	18	16	16	18	2.0E-001	81.1%	2.9	2.6	2.6	3.0
Nickel	0	24	2	2	1.1E-001	48.6%	0.0	1.3	0.1	0.1
Titanium	8	10	8	8	2.9E-002	8.2%	0.0	0.0	0.0	0.0
Trans-permethrin	6	6	6	6	4.5E+000	50.0%	12.6	12.6	12.6	12.6
Vanadium	2	1	2	3	6.2E-001	90.5%	1.1	0.3	0.9	2.0
Zinc	469	524	549	549	4.7E-002	20.9%	4.6	5.1	5.4	5.4
Total	11,093	418,656	411,265	414,188			2,819	3,315	3,299	3,304
<u>Nutrients</u>										
Total Nitrogen	0	0	312,139	324,323	NA	100.0%	0	0	312,139	324,323
Total Phosphorus	42,203	49,717	61,245	61,245	NA	42.6%	17,974	21,174	26,084	26,084
Total	42,203	49,717	373,384	385,568			17,974	21,174	338,223	350,407

Note: Numbers may not sum due to rounding

Supplement 2 - Table 6 (continued)
Pollutant Removals - By Option and Size
Subcategory A through D - Indirect Dischargers

Pollutants	Removals (Pounds/Year)				TWF	POTW Removal Factor	Removals (Pounds Equivalent/Year)			
	PSES1	PSES2	PSES3	PSES4			PSES1	PSES2	PSES3	PSES4
NONSMALL FACILITY REMOVALS										
<u>Toxics</u>										
Ammonia as Nitrogen	0	58,596,684	57,432,209	57,689,265	1.8E-003	61.1%	0.0	65,475.8	64,174.6	64,461.9
Carbaryl	1,203	1,203	1,203	1,203	2.8E+002	70.0%	235,845.0	235,845.0	235,845.0	235,845.0
Nitrate/Nitrite	1,657,424	1,566,765	1,566,765	1,566,765	6.2E-005	10.0%	10.3	9.7	9.7	9.7
Barium	0	0	0	0	2.0E-003	84.0%	0.0	0.0	0.0	0.0
Copper	6,168	8,937	9,057	9,167	6.3E-001	15.8%	611.0	885.3	897.3	908.1
Chromium	4,271	5,808	5,410	5,431	7.6E-002	19.7%	63.6	86.5	80.6	80.9
Cis-permethrin	735	735	735	735	4.5E+000	50.0%	1,668.6	1,668.6	1,668.6	1,668.6
Manganese	0	99,057	92,076	92,076	7.0E-002	64.5%	0.0	4,497.3	4,180.3	4,180.3
Molybdenum	1,722	1,389	1,220	1,617	2.0E-001	81.1%	280.7	226.4	198.8	263.5
Nickel	0	1,821	0	0	1.1E-001	48.6%	0.0	96.4	0.0	0.0
Titanium	240	468	269	269	2.9E-002	8.2%	0.6	1.1	0.6	0.6
Trans-permethrin	725	725	725	725	4.5E+000	50.0%	1,645.6	1,645.6	1,645.6	1,645.6
Vanadium	52	0	32	204	6.2E-001	90.5%	29.2	0.0	18.2	114.8
Zinc	27,351	33,910	37,156	37,156	4.7E-002	20.9%	266.4	330.3	362.0	362.0
Total	1,699,890	60,317,502	59,146,857	59,404,612			240,421	310,768	309,081	309,541
<u>Nutrients</u>										
Total Nitrogen	0	0	31,518,545	32,896,309	NA	100.0%	0	0	31,518,545	32,896,309
Total Phosphorus	2,130,376	3,694,100	5,445,526	5,445,526	NA	42.6%	907,327	1,573,317	2,319,250	2,319,250
Total	2,130,376	3,694,100	36,964,072	38,341,835			907,327	1,573,317	33,837,795	35,215,559

Note: Numbers may not sum due to rounding

**Supplement 2 - Table 7
Pollutant Removals - By Option and Size
Subcategory E through I - Indirect Dischargers**

Pollutants	Removals (Pounds/Year)				TWF	POTW Removal Factor	Removals (Pounds Equivalent/Year)			
	PSES1	PSES2	PSES3	PSES4			PSES1	PSES2	PSES3	PSES4
SMALL FACILITY REMOVALS										
<u>Toxics</u>										
Ammonia as Nitrogen	58,379	98,086	98,018	98,016	1.8E-003	61.1%	65.2	109.6	109.5	109.5
Carbaryl	7	7	7	7	2.8E+002	70.0%	1,380.6	1,380.6	1,380.6	1,380.6
Nitrate/Nitrite	34,716	34,716	34,716	34,716	6.2E-005	10.0%	0.2	0.2	0.2	0.2
Barium	36	36	39	35	2.0E-003	84.0%	0.1	0.1	0.1	0.1
Copper	183	196	200	200	6.3E-001	15.8%	18.1	19.4	19.8	19.8
Chromium	34	36	34	37	7.6E-002	19.7%	0.5	0.5	0.5	0.6
Cis-permethrin	2	2	2	2	4.5E+000	50.0%	5.1	5.1	5.1	5.1
Manganese	10	76	72	67	7.0E-002	64.5%	0.4	3.5	3.3	3.0
Molybdenum	36	32	25	25	2.0E-001	81.1%	5.8	5.2	4.1	4.1
Nickel	1	16	7	5	1.1E-001	48.6%	0.1	0.9	0.4	0.3
Titanium	11	12	11	11	2.9E-002	8.2%	0.0	0.0	0.0	0.0
Trans-permethrin	2	2	2	2	4.5E+000	50.0%	4.9	4.9	4.9	4.9
Vanadium	5	4	5	5	6.2E-001	90.5%	2.8	2.1	2.8	2.8
Zinc	549	626	697	676	4.7E-002	20.9%	5.3	6.1	6.8	6.6
Total	93,970	133,846	133,836	133,804			1,489	1,538	1,538	1,537
<u>Nutrients</u>										
Total Nitrogen	84,284	0	122,858	124,047	NA	100.0%	84,284	0	122,858	124,047
Total Phosphorus	88,372	143,575	175,351	172,209	NA	42.6%	37,637	61,149	74,682	73,344
Total	172,656	143,575	298,209	296,256			121,922	61,149	197,540	197,391

Note: Numbers may not sum due to rounding

Supplement 2 - Table 7 (continued)
Pollutant Removals - By Option and Size
Subcategory E through I - Indirect Dischargers

Pollutants	Removals (Pounds/Year)				TWF	POTW Removal Factor	Removals (Pounds Equivalent/Year)			
	PSES1	PSES2	PSES3	PSES4			PSES1	PSES2	PSES3	PSES4
NONSMALL FACILITY REMOVALS										
<u>Toxics</u>										
Ammonia as Nitrogen	3,017,636	4,629,729	4,627,221	4,627,122	1.8E-003	61.1%	3,371.9	5,173.2	5,170.4	5,170.3
Carbaryl	365	365	365	365	2.8E+002	70.0%	71,466.5	71,466.5	71,466.5	71,466.5
Nitrate/Nitrite	363,531	363,531	363,531	363,531	6.2E-005	10.0%	2.3	2.3	2.3	2.3
Barium	2,275	2,292	2,492	2,219	2.0E-003	84.0%	3.8	3.8	4.2	3.7
Copper	4,942	5,332	5,460	5,432	6.3E-001	15.8%	489.6	528.2	540.9	538.1
Chromium	1,219	1,140	1,115	1,231	7.6E-002	19.7%	18.2	17.0	16.6	18.3
Cis-permethrin	303	303	303	303	4.5E+000	50.0%	688.2	688.2	688.2	688.2
Manganese	2,658	5,100	4,946	4,635	7.0E-002	64.5%	120.7	231.6	224.6	210.4
Molybdenum	913	794	636	629	2.0E-001	81.1%	148.7	129.3	103.7	102.6
Nickel	683	1,112	877	753	1.1E-001	48.6%	36.2	58.9	46.4	39.8
Titanium	266	285	276	262	2.9E-002	8.2%	0.6	0.7	0.7	0.6
Trans-permethrin	168	168	168	168	4.5E+000	50.0%	380.6	380.6	380.6	380.6
Vanadium	111	79	121	112	6.2E-001	90.5%	62.6	44.6	68.0	63.0
Zinc	10,250	10,892	14,611	13,217	4.7E-002	20.9%	99.9	106.1	142.3	128.8
Total	3,405,320	5,021,121	5,022,121	5,019,977			76,890	78,831	78,855	78,813
<u>Nutrients</u>										
Total Nitrogen	1,309,195	0	2,736,823	2,811,178	NA	100.0%	1,309,195	0	2,736,823	2,811,178
Total Phosphorus	1,616,447	3,545,450	4,413,741	4,207,979	NA	42.6%	688,445	1,510,007	1,879,812	1,792,178
Total	2,925,643	3,545,450	7,150,564	7,019,157			1,997,640	1,510,007	4,616,635	4,603,357

Note: Numbers may not sum due to rounding

**Supplement 2 - Table 8
Pollutant Removals - By Option and Size
Subcategory J - Indirect Dischargers**

Pollutants	Removals (Pounds/Year)				TWF	POTW Removal Factor	Removals (Pounds Equivalent/Year)			
	PSES1	PSES2	PSES3	PSES4			PSES1	PSES2	PSES3	PSES4
SMALL FACILITY REMOVALS										
<u>Toxics</u>										
Ammonia as Nitrogen	245,362	498,466	497,974	497,892	1.8E-003	61.1%	274.2	557.0	556.4	556.3
Carbaryl	51	51	51	51	2.8E+002	70.0%	9,898.7	9,898.7	9,898.7	9,898.7
Nitrate/Nitrite	0	0	0	2,147	6.2E-005	10.0%	0.0	0.0	0.0	0.0
Barium	0	0	0	0	2.0E-003	84.0%	0.0	0.0	0.0	0.0
Copper	345	364	391	371	6.3E-001	15.8%	34.2	36.0	38.7	36.8
Chromium	238	241	240	248	7.6E-002	19.7%	3.5	3.6	3.6	3.7
Cis-permethrin	21	21	21	21	4.5E+000	50.0%	48.0	48.0	48.0	48.0
Manganese	427	877	848	640	7.0E-002	64.5%	19.4	39.8	38.5	29.1
Molybdenum	66	66	65	64	2.0E-001	81.1%	10.8	10.7	10.5	10.4
Nickel	6	19	11	0	1.1E-001	48.6%	0.3	1.0	0.6	0.0
Titanium	0	0	0	0	2.9E-002	8.2%	0.0	0.0	0.0	0.0
Trans-permethrin	21	21	21	21	4.5E+000	50.0%	47.0	47.0	47.0	47.0
Vanadium	0	0	0	0	6.2E-001	90.5%	0.0	0.0	0.0	0.0
Zinc	1,190	1,222	1,520	1,398	4.7E-002	20.9%	11.6	11.9	14.8	13.6
Total	247,727	501,347	501,141	502,853			10,348	10,654	10,657	10,644
<u>Nutrients</u>										
Total Nitrogen	5,235,050	0	5,779,752	5,834,977	NA	100.0%	5,235,050	0	5,779,752	5,834,977
Total Phosphorus	218,858	236,900	253,603	247,609	NA	42.6%	93,212	100,896	108,010	105,456
Total	5,453,908	236,900	6,033,356	6,082,586			5,328,261	100,896	5,887,762	5,940,434

Note: Numbers may not sum due to rounding

Supplement 2 - Table 8 (continued)
Pollutant Removals - By Option and Size
Subcategory J - Indirect Dischargers

Pollutants	Removals (Pounds/Year)				TWF	POTW Removal Factor	Removals (Pounds Equivalent/Year)			
	PSES1	PSES2	PSES3	PSES4			PSES1	PSES2	PSES3	PSES4
NONSMALL FACILITY REMOVALS										
<u>Toxics</u>										
Ammonia as Nitrogen	271,224	1,158,339	1,156,617	1,156,329	1.8E-003	61.1%	303.1	1,294.3	1,292.4	1,292.1
Carbaryl	17	17	17	17	2.8E+002	70.0%	3,293.7	3,293.7	3,293.7	3,293.7
Nitrate/Nitrite	74,509	70,227	139,380	279,610	6.2E-005	10.0%	0.5	0.4	0.9	1.7
Barium	0	0	0	0	2.0E-003	84.0%	0.0	0.0	0.0	0.0
Copper	0	20	116	47	6.3E-001	15.8%	0.0	2.0	11.5	4.6
Chromium	1	13	10	36	7.6E-002	19.7%	0.0	0.2	0.1	0.5
Cis-permethrin	68	68	68	68	4.5E+000	50.0%	154.4	154.4	154.4	154.4
Manganese	283	1,860	1,759	1,031	7.0E-002	64.5%	12.8	84.4	79.9	46.8
Molybdenum	6	4	0	0	2.0E-001	81.1%	1.1	0.7	0.1	0.0
Nickel	0	7	0	0	1.1E-001	48.6%	0.0	0.4	0.0	0.0
Titanium	0	0	0	0	2.9E-002	8.2%	0.0	0.0	0.0	0.0
Trans-permethrin	67	67	67	67	4.5E+000	50.0%	152.6	152.6	152.6	152.6
Vanadium	0	0	209	0	6.2E-001	90.5%	0.0	0.0	117.4	0.0
Zinc	0	0	940	514	4.7E-002	20.9%	0.0	0.0	9.2	5.0
Total	346,175	1,230,622	1,299,182	1,437,717			3,918	4,983	5,112	4,951
<u>Nutrients</u>										
Total Nitrogen	8,114,088	0	10,023,243	10,216,804	NA	100.0%	8,114,088	0	10,023,243	10,216,804
Total Phosphorus	281,232	344,466	403,012	382,001	NA	42.6%	119,777	146,708	171,643	162,694
Total	8,395,320	344,466	10,426,255	10,598,805			8,233,864	146,708	10,194,886	10,379,498

Note: Numbers may not sum due to rounding

**Supplement 2 - Table 9
Pollutant Removals - By Option and Size
Subcategory K - Indirect Dischargers**

Pollutants	Removals (Pounds/Year)				TWF	POTW Removal Factor	Removals (Pounds Equivalent/Year)			
	PSES1	PSES2	PSES3	PSES4			PSES1	PSES2	PSES3	PSES4
SMALL FACILITY REMOVALS										
<u>Toxics</u>										
Ammonia as Nitrogen	246	5,198	5,198	5,236	1.8E-003	61.1%	0.3	5.8	5.8	5.9
Carbaryl	107	107	107	107	2.8E+002	70.0%	21,063.4	21,063.4	21,063.4	21,063.4
Nitrate/Nitrite	460	0	212	235	6.2E-005	10.0%	0.0	0.0	0.0	0.0
Barium	17	22	25	10	2.0E-003	84.0%	0.0	0.0	0.0	0.0
Copper	62	75	75	78	6.3E-001	15.8%	6.1	7.4	7.4	7.7
Chromium	0	0	0	0	7.6E-002	19.7%	0.0	0.0	0.0	0.0
Cis-permethrin	0	0	0	0	4.5E+000	50.0%	0.0	0.0	0.0	0.0
Manganese	0	34	34	0	7.0E-002	64.5%	0.0	1.5	1.5	0.0
Molybdenum	0	0	0	0	2.0E-001	81.1%	0.0	0.0	0.0	0.0
Nickel	2	4	4	2	1.1E-001	48.6%	0.1	0.2	0.2	0.1
Titanium	0	0	0	0	2.9E-002	8.2%	0.0	0.0	0.0	0.0
Trans-permethrin	0	0	0	0	4.5E+000	50.0%	0.0	0.0	0.0	0.0
Vanadium	0	0	0	0	6.2E-001	90.5%	0.0	0.0	0.0	0.0
Zinc	139	107	138	126	4.7E-002	20.9%	1.4	1.0	1.3	1.2
Total	1,034	5,547	5,792	5,794			21,071	21,079	21,080	21,078
<u>Nutrients</u>										
Total Nitrogen	5,390	0	23,581	24,845	NA	100.0%	5,390	0	23,581	24,845
Total Phosphorus	2,414	6,691	7,057	6,842	NA	42.6%	1,028	2,850	3,006	2,914
Total	7,805	6,691	30,638	31,686			6,419	2,850	26,587	27,759

Note: Numbers may not sum due to rounding

Supplement 2 - Table 9 (continued)
Pollutant Removals - By Option and Size
Subcategory K - Indirect Dischargers

Pollutants	Removals (Pounds/Year)				TWF	POTW Removal Factor	Removals (Pounds Equivalent/Year)			
	PSES1	PSES2	PSES3	PSES4			PSES1	PSES2	PSES3	PSES4
NONSMALL FACILITY REMOVALS										
<u>Toxics</u>										
Ammonia as Nitrogen	1,041,784	3,805,507	3,805,507	3,821,706	1.8E-003	61.1%	1,164.1	4,252.3	4,252.3	4,270.4
Carbaryl	1,917	1,917	1,917	1,917	2.8E+002	70.0%	375,828.7	375,828.7	375,828.7	375,828.7
Nitrate/Nitrite	1,488,756	0	918,585	1,811,109	6.2E-005	10.0%	9.2	0.0	5.7	11.2
Barium	2,043	3,887	5,411	258	2.0E-003	84.0%	3.4	6.5	9.0	0.4
Copper	672	6,232	6,453	7,526	6.3E-001	15.8%	66.6	617.3	639.2	745.6
Chromium	0	0	0	0	7.6E-002	19.7%	0.0	0.0	0.0	0.0
Cis-permethrin	0	0	0	0	4.5E+000	50.0%	0.0	0.0	0.0	0.0
Manganese	9,643	38,576	38,576	16,100	7.0E-002	64.5%	437.8	1,751.4	1,751.4	730.9
Molybdenum	0	0	0	0	2.0E-001	81.1%	0.0	0.0	0.0	0.0
Nickel	0	0	0	0	1.1E-001	48.6%	0.0	0.0	0.0	0.0
Titanium	0	0	0	0	2.9E-002	8.2%	0.0	0.0	0.0	0.0
Trans-permethrin	0	0	0	0	4.5E+000	50.0%	0.0	0.0	0.0	0.0
Vanadium	0	0	0	0	6.2E-001	90.5%	0.0	0.0	0.0	0.0
Zinc	14,470	9,604	25,516	16,820	4.7E-002	20.9%	141.0	93.6	248.6	163.9
Total	2,559,286	3,865,723	4,801,965	5,675,437			377,651	382,550	382,735	381,751
<u>Nutrients</u>										
Total Nitrogen	3,849,894	0	15,404,773	16,422,369	NA	100.0%	3,849,894	0	15,404,773	16,422,369
Total Phosphorus	3,799,713	6,638,530	7,044,383	6,562,508	NA	42.6%	1,618,298	2,827,350	3,000,203	2,794,972
Total	7,649,607	6,638,530	22,449,157	22,984,877			5,468,191	2,827,350	18,404,976	19,217,341

Note: Numbers may not sum due to rounding

**Supplement 2 - Table 10
Pollutant Removals - By Option and Size
Subcategory L - Indirect Dischargers**

Pollutants	Removals (Pounds/Year)				TWF	POTW Removal Factor	Removals (Pounds Equivalent/Year)			
	PSES1	PSES2	PSES3	PSES4			PSES1	PSES2	PSES3	PSES4
SMALL FACILITY REMOVALS										
<u>Toxics</u>										
Ammonia as Nitrogen	32,393	47,281	47,276	47,272	1.8E-003	61.1%	36.2	52.8	52.8	52.8
Carbaryl	5	5	5	5	2.8E+002	70.0%	983.0	983.0	983.0	983.0
Nitrate/Nitrite	1,501	1,501	1,623	2,068	6.2E-005	10.0%	0.0	0.0	0.0	0.0
Barium	46	47	52	42	2.0E-003	84.0%	0.1	0.1	0.1	0.1
Copper	33	37	39	37	6.3E-001	15.8%	3.3	3.7	3.8	3.7
Chromium	2	0	0	2	7.6E-002	19.7%	0.0	0.0	0.0	0.0
Cis-permethrin	2	2	2	2	4.5E+000	50.0%	3.5	3.5	3.5	3.5
Manganese	14	23	23	10	7.0E-002	64.5%	0.6	1.1	1.0	0.4
Molybdenum	4	4	3	3	2.0E-001	81.1%	0.7	0.6	0.5	0.5
Nickel	8	11	11	6	1.1E-001	48.6%	0.4	0.6	0.6	0.3
Titanium	2	2	2	2	2.9E-002	8.2%	0.0	0.0	0.0	0.0
Trans-permethrin	1	1	1	1	4.5E+000	50.0%	3.3	3.3	3.3	3.3
Vanadium	1	1	1	1	6.2E-001	90.5%	0.4	0.4	0.5	0.4
Zinc	241	363	484	431	4.7E-002	20.9%	2.3	3.5	4.7	4.2
Total	34,254	49,280	49,522	49,881			1,034	1,053	1,054	1,052
<u>Nutrients</u>										
Total Nitrogen	68,493	0	88,186	90,489	NA	100.0%	68,493	0	88,186	90,489
Total Phosphorus	69,728	106,629	113,817	106,073	NA	42.6%	29,697	45,413	48,475	45,176
Total	138,220	106,629	202,003	196,562			98,190	45,413	136,661	135,665

Note: Numbers may not sum due to rounding

Supplement 2 - Table 10 (continued)
Pollutant Removals - By Option and Size
Subcategory L - Indirect Dischargers

Pollutants	Removals (Pounds/Year)				TWF	POTW Removal Factor	Removals (Pounds Equivalent/Year)			
	PSES1	PSES2	PSES3	PSES4			PSES1	PSES2	PSES3	PSES4
NONSMALL FACILITY REMOVALS										
<u>Toxics</u>										
Ammonia as Nitrogen	672,854	1,736,803	1,736,488	1,735,976	1.8E-003	61.1%	751.8	1,940.7	1,940.3	1,939.8
Carbaryl	247	247	247	247	2.8E+002	70.0%	48,391.1	48,391.1	48,391.1	48,391.1
Nitrate/Nitrite	43,625	43,625	50,062	144,050	6.2E-005	10.0%	0.3	0.3	0.3	0.9
Barium	2,488	2,611	2,972	2,131	2.0E-003	84.0%	4.2	4.4	5.0	3.6
Copper	1,727	1,992	2,156	2,021	6.3E-001	15.8%	171.1	197.3	213.6	200.2
Chromium	112	0	0	65	7.6E-002	19.7%	1.7	0.0	0.0	1.0
Cis-permethrin	86	86	86	86	4.5E+000	50.0%	194.2	194.2	194.2	194.2
Manganese	1,988	2,592	2,572	1,115	7.0E-002	64.5%	90.3	117.7	116.8	50.6
Molybdenum	236	200	169	165	2.0E-001	81.1%	38.4	32.6	27.6	26.9
Nickel	188	297	254	174	1.1E-001	48.6%	9.9	15.7	13.4	9.2
Titanium	66	73	72	63	2.9E-002	8.2%	0.2	0.2	0.2	0.2
Trans-permethrin	82	82	82	82	4.5E+000	50.0%	186.3	186.3	186.3	186.3
Vanadium	24	19	32	26	6.2E-001	90.5%	13.7	10.4	17.8	14.6
Zinc	9,976	17,040	26,733	22,460	4.7E-002	20.9%	97.2	166.0	260.4	218.8
Total	733,700	1,805,667	1,821,925	1,908,662			49,950	51,257	51,367	51,237
<u>Nutrients</u>										
Total Nitrogen	1,983,785	0	3,799,359	4,078,127	NA	100.0%	1,983,785	0	3,799,359	4,078,127
Total Phosphorus	1,717,941	4,446,429	4,960,305	4,363,637	NA	42.6%	731,671	1,893,734	2,112,594	1,858,473
Total	3,701,726	4,446,429	8,759,665	8,441,764			2,715,456	1,893,734	5,911,953	5,936,600

Note: Numbers may not sum due to rounding

APPENDIX G

SURVEY FORMS



**U.S. Environmental Protection Agency
Office of Water
Washington, DC**

**2001 Meat Products Industry
Screener Survey**

February, 2001

Form Approved



OMB Control No. 2040-0225



Expiration Date 02/29/2004

**U.S. ENVIRONMENTAL PROTECTION AGENCY
2001 MEAT PRODUCTS INDUSTRY SCREENER SURVEY**

TABLE OF CONTENTS

	Page
INTRODUCTION	i
Completion of the Survey	i
Authority	ii
Notice of Estimated Burden	ii
Provisions Regarding Data Confidentiality	ii
Where to Return the Survey	iii
Certification Statement	iii
General Instructions	v
DEFINITIONS	vi

INTRODUCTION

The U.S. Environmental Protection Agency (EPA) is conducting a survey of the Meat Products Industry as part of its effort to review and revise, as appropriate, effluent limitations guidelines and standards for this industry. This Screener Survey requests data on sites engaged in meat product operations. The data collected with this Screener Survey will be used to better define basic characteristics of facilities in this industry. Knowing the basic characteristics of the industry will allow EPA to adequately estimate the possible economic impacts of wastewater regulations.

COMPLETION OF THE SCREENER SURVEY

The Screener Survey should be completed by the person(s) most knowledgeable about the information requested. All sites must have the corporate official or designee responsible for directing or supervising of the survey response sign the Certification Statement (located on page iv) to verify and validate the information provided, or to certify that this site does not engage in meat product processes.

You are not required to perform nonroutine tests or measurements solely for the purpose of responding to this Screener Survey. In the event that exact data are not available, provide best engineering estimates and note the basis for the estimates on the Comments page located at the end of the survey. General instructions are provided on page v, and additional instructions are provided as needed with each question. A complete set of definitions can be found in the Definitions Section, starting on page vi.

EPA MEAT PRODUCTS SCREENER SURVEY HELP LINE

Westat. (888) 296-5146
Internet Electronic Mailing Address EPAMeatProductsSurvey@Westat.com

AUTHORITY

This Screener Survey is conducted under authority of Section 308 of the Clean Water Act (Federal Water Pollution Control Act, 33 U.S.C. Section 1318). **All sites that receive this Screener Survey must respond to it.** Return all portions of the survey to the EPA **within 30 days** of receiving it. Late filing or failure to comply with these instructions may result in criminal fines, civil penalties, and other sanctions, as provided by law.

If you wish to request an extension for your site or discuss a delivery schedule for a company with multiple sites, you must do so **in writing** within 20 days of receipt of this Screener Survey. Send written requests to:

Ms. Samantha Lewis
U.S. Environmental Protection Agency (4303)
1200 Pennsylvania Avenue NW
Washington, DC 20460

Extension requests will be evaluated on a case-by-case basis. Submittal of an extension request to EPA does **not** alter the due date of your survey, unless and until EPA agrees to an extension.

NOTICE OF ESTIMATED BURDEN

EPA estimates that completion of the entire Meat Products Industry Screener Survey will require an average of 2 hours per plant. This estimate includes time for reading the instructions and reviewing the information necessary to respond to the screener survey form. Any comments regarding EPA's need for the information, the accuracy of the provided burden estimate, and suggested methods for reducing respondent burden (including the use of automated collection techniques) should be addressed to: ***Director, Regulatory Information Division, Office of Policy, Mail Code 2137, U.S. EPA, 1200 Pennsylvania Avenue, N.W., Washington, D.C. 20460 and to the Office of Information and Regulatory Affairs, Office of Management and Budget, 725 17th Street, N.W., Washington, D.C. 20503, Attn: Desk Officer for EPA Office of Water.*** Respondents should be aware that notwithstanding any other provision of law, an Agency may not conduct or sponsor, and a person is not required to respond to, a collection of information unless it displays a currently valid OMB Control Number. Please include the OMB Control Number listed on this page with any correspondence.

PROVISIONS REGARDING DATA CONFIDENTIALITY

Regulations governing the confidentiality of business information are contained in the Code of Federal Regulations (CFR) at Title 40 Part 2, Subpart B. You may assert a business confidentiality claim covering part or all of the information you submit, **other than effluent data**, as described in 40 CFR 2.203(b):

“(b) Method and time of asserting business confidentiality claim. A business which is submitting information to EPA may assert a business confidentiality claim covering the information by placing on (or attaching to) the information, at the time it is submitted to EPA, a cover sheet, stamped or typed legend, or other suitable form of notice complying language such as ‘trade secret,’ ‘proprietary,’ or ‘company confidential.’ Allegedly confidential portions of otherwise nonconfidential documents should be clearly identified by the business, and may be submitted separately to facilitate identification and handling by EPA. If the business desires confidential treatment only until a certain date or until the occurrence of a certain event, the notice should so state.”

If no business confidentiality claim accompanies the information when it is received by EPA, EPA may make the information available to the public without further notice.

You may claim as confidential all information included in the response to a question by checking the Confidential Business Information (CBI) box next to each question number for which responses contain CBI. Alternatively, all questions in this survey marked with a CBI check box may be claimed confidential now by checking the box at the end of this paragraph. If you do not check this box, any individual response where “CBI” is **NOT** checked will be considered nonconfidential. Note that you may be required to justify any claim of confidentiality at a later time. Note also that plant effluent data are not eligible for confidential treatment, pursuant to Section 308(b) of

the Clean Water Act, and thus will be treated as nonconfidential even if the "all CBI" box is checked. **All Eligible Data are CBI**

Information covered by a claim of confidentiality will be disclosed by EPA only to the extent of, and by means of, the procedures set forth in 40 CFR Part 2, Subpart B. In general, submitted information protected by a business confidentiality claim may be disclosed to other employees, officers, or authorized representatives of the United States concerned with implementing the Clean Water Act.

Information covered by a claim of confidentiality will be made available to EPA contractors under EPA Contract Numbers 68-C-99-263, 68-C6-0022, and 68-C4-99-242 to enable the contractors to perform the work required by their contracts with EPA. All EPA contracts provide that contractor employees use the information only for the purpose of performing the work required by their contracts and will not disclose any CBI to anyone other than EPA without prior written approval from each affected business or from EPA's legal office. Any comments you may wish to make on this issue must be submitted in writing along with your completed survey.

WHERE TO RETURN THE SCREENER SURVEY

After completing the Screener Survey and certifying the information that it contains, use the enclosed envelope to mail the completed survey to:

U.S. Environmental Protection Agency
2001 Meat Products Industry Survey
c/o Westat
1650 Research Blvd.
Rockville, MD 20850-9973

Retain a copy of the completed survey, including attachments. EPA will review the information submitted and may request your cooperation in answering follow-up questions, if necessary, to complete our analyses.

CERTIFICATION STATEMENT

Was your site engaged in full-time, part-time or intermittent meat product operations **during 1999?** (For purposes of this survey, meat product operations include red meat and poultry slaughtering operations, by-product operations, rendering, and further processing.)

- Yes (Complete the survey; **sign Certification Statement #1** on page iv when survey has been completed)
- No (Sign Certification Statement #2 on page iv and return the following to EPA at the given address: Pages iii and iv and the cover page containing the site address label)

When the survey has been completed or "No" has been checked above, the individual responsible for directing or supervising the preparation of this survey must read and sign the appropriate Certification Statement listed below. The certifying official must be a responsible corporate official or his/her authorized representative.

Certification Statement #1

I certify under penalty of law that the enclosed survey response was prepared under my direction or supervision in accordance with a system designed to assure that qualified personnel properly gathered and evaluated the information submitted. The information submitted is, to the best of my knowledge and belief, accurate and complete. In those cases where we did not possess the requested information, we provided best engineering estimates in response to the questions. I am aware that there are significant penalties for submitting false information, including the possibility of fines and imprisonment as explained in Section 308 of the Clean Water Act.

Signature of Certifying Official

Date

Printed Name of Certifying Official

()

Telephone Number

Title of Certifying Official

Certification Statement #2

I certify under penalty of law that this site did not engage in meat product operations during 1999. I am aware that there are significant penalties for submitting false information, including the possibility of fines and imprisonment as explained in Section 308 of the Clean Water Act.

If you are certifying that your site was not engaged in meat product operations in 1999, indicate the classification of your site.

- G Office
- G Distribution
- G Other (specify): _____

Signature of Certifying Official

Date

Printed Name of Certifying Official

()

Telephone Number

Title of Certifying Official

GENERAL INSTRUCTIONS

Complete this survey for your entire site. A site is one contiguous physical location at which meat product processes occur. In some instances, a site may include properties located within separate fence lines, but located close to each other.

Mark responses for each question. Fill in the appropriate response(s) to each question. Use **black ink** or **type** in the spaces provided. If the space allowed for the answer to any question is inadequate for your complete response, continue the response in the Comments area at the end of the survey, cross-referencing the appropriate section and question number. If additional attachments are required to clarify a response, place the associated question number and your site ID number (shown on the cover page) in the upper right corner of each page of the attachments.

Answer all questions unless instructed otherwise. The purpose of this survey is to gather necessary information pertinent to meat product processes. Answer the questions in sequence unless you are directed to SKIP. Report only whole numbers, unless instructed otherwise. If a particular part of the required information is not applicable to your site, enter "NA" rather than leaving the answer blank. Enter zero where appropriate. Do not leave an entry blank if the answer is zero. You are required to provide best engineering estimates when data are not readily available. If you provide an estimate, note the basis for the estimates on the Comments page at the end of the survey. EPA does not intend for sites to conduct detailed studies to obtain the data. If you feel you need to conduct a detailed study, please call the Screener Survey Information Help Line at (888) 296-5146 or email your questions to EPAMeatProductsSurvey@Westat.com.

Pay close attention to the measurement units requested. Be careful to provide data in the requested units, where available, or note where alternate units are used.

Retain a copy of the completed survey for your records. EPA will review the information submitted and may request, if necessary, your cooperation in answering follow-up clarification questions to complete the data collection effort. Retain a copy of the completed survey, including attachments, in case you (i.e., the contact identified in Question 4) are contacted to clarify your responses. Also, please maintain a record of sources used to complete the questions.

Refer to the Definitions Section for terms which are used in this survey.

If you have any comments on a question or you feel an answer needs clarification, use the Comments page at the end of the survey. Be sure to cross-reference your comments by question number.

Indicate information which should be treated as confidential by checking the Confidential Business Information (CBI) box next to each question number with responses containing CBI, or you may designate all eligible information as CBI by using the global CBI check-off box on page iii. If you do not use the global CBI check off box, any response where "CBI" is not individually checked will be considered nonconfidential. Refer to the instructions given in the PROVISIONS REGARDING DATA CONFIDENTIALITY section on page ii for additional information regarding EPA's confidentiality procedures set forth in 40 CFR Part 2, Subpart B. The individual CBI boxes begin with Question 5.

DEFINITIONS

Effluent Limitations Guidelines and Standards. Regulations promulgated by U.S. EPA under authority of Sections 301, 304, 306, and 307 of the Clean Water Act that set out minimum, national technology-based standards of performance for point source wastewater discharges from specific industrial categories (e.g., iron and steel manufacturing plants). Effluent limitations guidelines and standards regulations are implemented through the NPDES permit and national pretreatment programs and include the following:

- Best Practicable Control Technology Currently Available (BPT)
- Best Available Technology Economically Achievable (BAT)
- Best Conventional Pollutant Control Technology (BCT)
- New Source Performance Standards (NSPS)
- Pretreatment Standards for Existing Sources (PSES)
- Pretreatment Standards for New Sources (PSNS)

The pretreatment standards (PSES, PSNS) are applicable to industrial facilities with process wastewater discharges to publicly owned treatment works (POTWs). The effluent limitations guidelines and new source performance standards (BPT, BAT, BCT, and NSPS) are applicable to industrial facilities with direct discharges of process wastewaters to waters of the United States.

Further Processing. Operations which utilize whole or cut-up meat products for the production of cooked, canned, ground, chopped, diced, or breaded fresh or frozen products.

Live Weight Killed (LWK). The total weight of the total number of animals slaughtered.

Meat Product Operations. Include red meat and poultry slaughtering operations, by-product operations, rendering, and further processing.

NPDES Program. The National Pollutant Discharge Elimination System (NPDES) program authorized by Sections 307, 318, 402, and 405 of the Clean Water Act which applies to facilities that discharge wastewater directly to United States surface waters.

Poultry. Broilers, other young chickens, hens, fowl, mature chickens, turkeys, capons, geese, ducks, and small game such as quail, pheasants, and rabbits.

Privately Owned Treatment Works (ProTWs). Any device or system owned and operated by a private entity and used for storage, treatment, recycling, or reclamation of liquid industrial wastes.

Process Wastewater. Any water which, during red meat or poultry operations, comes into direct contact with or results from the storage, production, or use of any raw material, intermediate product, finished product, by-product, or waste product. Wastewater from equipment cleaning, direct-contact air pollution control devices, rinse water, storm water associated with industrial activity, and contaminated cooling water are considered process wastewater. Process wastewater may also include wastewater that is contract hauled for off-site disposal. Sanitary wastewater, uncontaminated noncontact cooling water, and storm water not associated with industrial activity are not considered process wastewater.

Publicly Owned Treatment Works (POTWs). Any device or system owned and operated by a public entity and used in the storage, treatment, recycling, or reclamation of liquid municipal sewage and/or liquid industrial wastes. The sewerage system that conveys wastewaters to treatment works is considered part of the POTW.

Red Meat. The term "red meat" includes all animal products from cattle, calves, hogs, sheep and lambs, etc., except those defined as Poultry.

Site. A site is generally one contiguous physical location at which manufacturing operations related to the meat products industry occur. This includes, but is not limited to, slaughtering, processing, and rendering. In some instances, a site may include properties located within separate fence lines, but located close to each other.

Surface Water. Waters of the United States as defined at 40 CFR 122.2.

Wastewater. See Process Wastewater.

Zero Discharge or Alternative Disposal Methods. Disposal of process and/or nonprocess wastewaters other than by direct discharge to a surface water or by indirect discharge to a POTW or PrOTW. Examples include land application, deep well injection, and contract hauling.

FACILITY INFORMATION

1. If the site mailing address shown on the front of the survey is correct, check () the box below. If it is not the correct address for this site, provide the correct site name and address in the spaces provided below.

G Address on cover page is correct **(Skip to Question 2)**

Company Name

Site Address or P.O. Box

Subsidiary Name (if any)

Site Address continued

Site or Plant Name

City

State

ZIP Code

2. If the street (i.e., physical) address of your site is different from the mailing address on the cover page or given in Question 1, provide the street address in the spaces provided below. If the mailing address and street address are the same, check () the box below.

G Address on cover page or response to Question 1 is physical address.

Street Address City

City

Street Address continued

State

ZIP Code

3. What is the name and address of the company that owns this site?

Name of Company _____

Mailing Address or P.O. Box _____

City _____

State _____

ZIP _____

4. Provide the name, title, telephone number, and facsimile number of the contact at your site for information supplied in this survey.

Contact Name

Contact Title

(_____) _____
Telephone Number

(_____) _____
Facsimile Number

6. Were any type(s) of process wastewaters (see definition of process wastewater on page vi) generated at your facility for Meat Product Operations in 1999?

G CBI

Yes (complete Table 6.1 below for all that apply) G

No G **(Skip to Question 7)**

Table 6.1

Check All That Apply	Wastewater Disposal Method	Amount of Process Wastewater Disposed in 1999 for Meat Product Operations (Gallons/Year)
G	Discharged to a surface water under an NPDES permit	
G	Discharged to publicly owned treatment works (POTW)	
G	Land applied on site	
G	Surface impoundment on site (as final disposal)	
G	Transferred to an off-site commercial waste treatment facility	
G	Transferred to an off-site intracompany wastewater treatment facility	
G	Other (Please specify _____)	

7. For fiscal year 1999, list the average number of full-time equivalent (FTE) employees at the site and company (i.e., 2080 hr/yr). For example, four half-time employees would be listed as two full-time equivalent employees.

G CBI

a. _____
Number of FTE employees at the site

b. _____
Number of FTE employees at the company

COMMENTS

Cross reference your comments by question number and indicate the confidential status of your comment by checking () the box in the column titled "CBI" (Confidential Business Information).

Question Number	CBI	Comment
	G	
	G	
	G	
	G	
	G	

Thank you for completing EPA's Screener Survey for the Meat Products Industry. We appreciate your cooperation. Please return the survey with a signed certification statement in the self-addressed envelope provided.



U.S. Environmental Protection Agency
Office of Water
Washington, DC

**2001 Meat Products Industry
Survey**

February, 2001

Form Approved



OMB Control No. 2040-0225



Expiration Date 02/29/2004

**U.S. ENVIRONMENTAL PROTECTION AGENCY
2001 MEAT PRODUCTS INDUSTRY SURVEY**

TABLE OF CONTENTS

	Page
INTRODUCTION	I
Completion of the Survey	I
Authority	ii
Provisions Regarding Data Confidentiality	ii
Where to Return the Survey	iii
Certification Statement	iii
General Instructions	v
DEFINITIONS	vi
FACILITY INFORMATION	1
PRODUCTION INFORMATION	3
WASTEWATER INFORMATION	11
TREATMENT INFORMATION	14
FINANCIAL INFORMATION	30
APPENDIX A - 1987 SIC CODES MATCHED TO 1997 NAICS CODES	39
APPENDIX B - PROCESS FLOW DIAGRAMS	42

NOTICE OF ESTIMATED BURDEN

EPA estimates that completion of the entire Meat Products Industry Survey will require an average of 40 hours per plant. This estimate includes time for reading the instructions and reviewing the information necessary to respond to the survey form. Any comments regarding EPA's need for the information, the accuracy of the provided burden estimate, and suggested methods for reducing respondent burden (including the use of automated collection techniques) should be addressed to: **Director, Regulatory Information Division, Office of Policy, Mail Code 2137, U.S. EPA, 1200 Pennsylvania Avenue, N.W., Washington, D.C. 20460 and to the Office of Information and Regulatory Affairs, Office of Management and Budget, 725 17th Street, N.W., Washington, D.C. 20503, Attn: Desk Officer for EPA Office of Water.** Respondents should be aware that notwithstanding any other provision of law, an Agency may not conduct or sponsor, and a person is not required to respond to, a collection of information unless it displays a currently valid OMB Control Number. Please include the OMB Control Number listed on this page with any correspondence.

INTRODUCTION

The U.S. Environmental Protection Agency (EPA) is conducting a survey of the Meat Products Industry as part of its effort to review and revise, as appropriate, effluent limitations guidelines and standards for this industry. This survey requests data on sites engaged in meat product processing. The technical data collected with this survey will be used to determine the production rates, use of water for processes, rates of wastewater generation, and the practices of wastewater management, treatment, and disposal of this industry. The financial and economic data collected in this survey will be used to characterize the economic status of the industry and to estimate the possible economic impacts of wastewater regulations.

COMPLETION OF THE SURVEY

The survey should be completed by the person(s) most knowledgeable about the information requested. All sites must have the corporate official or designee responsible for directing or supervising of the survey response sign the Certification Statement (located on page iv) to verify and validate the information provided, or to certify that this site does not engage in meat product processes.

EPA has prepared this survey to be applicable to a variety of processes and operations; therefore, not all of the questions will apply to each site. Complete each applicable item in the survey. You are not required to perform nonroutine tests or measurements solely for the purpose of responding to this survey. In the event that exact data are not available, provide best engineering estimates and note the basis for the estimates on the Comments page located at the end of the survey. General instructions are provided on page v, and additional instructions are provided as needed with each question. A complete set of definitions can be found in the Definitions Section, starting on page vi.

If you would like to request a WordPerfect 8 version of the survey instrument, you must do so **in writing** within 10 days of receipt of this survey (see address under **WHERE TO RETURN THE SURVEY** on page iii). You are responsible for submitting a properly formatted hard copy of the survey by the due date which matches this survey's format. The electronic formatting of this survey is complex and may require more experienced clerical support. **Improperly formatted survey responses will be returned to the respondent!**

EPA MEAT PRODUCTS SURVEY HELP LINE

Westat. (888) 296-5146
Internet Electronic Mailing Address EPAMeatProductsSurvey@Westat.com

AUTHORITY

This survey is conducted under authority of Section 308 of the Clean Water Act (Federal Water Pollution Control Act, 33 U.S.C. Section 1318). **All sites that receive this survey must respond to it.** Return all portions of the survey to the EPA **within 60 days** of receiving it. Late filing or failure to comply with these instructions may result in criminal fines, civil penalties, and other sanctions, as provided by law.

If you wish to request an extension for your site or discuss a delivery schedule for a company with multiple sites, you must do so **in writing** within 20 days of receipt of this survey. Send written requests to:

Ms. Samantha Lewis
U.S. Environmental Protection Agency (4303)
1200 Pennsylvania Avenue NW
Washington, DC 20460

Extension requests will be evaluated on a case-by-case basis. Submittal of an extension request to EPA does **not** alter the due date of your survey, unless and until EPA agrees to an extension.

PROVISIONS REGARDING DATA CONFIDENTIALITY

Regulations governing the confidentiality of business information are contained in the Code of Federal Regulations (CFR) at Title 40 Part 2, Subpart B. You may assert a business confidentiality claim covering part or all of the information you submit, other than effluent data, as described in 40 CFR 2.203(b):

“(b) Method and time of asserting business confidentiality claim. A business which is submitting information to EPA may assert a business confidentiality claim covering the information by placing on (or attaching to) the information, at the time it is submitted to EPA, a cover sheet, stamped or typed legend, or other suitable form of notice complying language such as ‘trade secret,’ ‘proprietary,’ or ‘company confidential.’ Allegedly confidential portions of otherwise nonconfidential documents should be clearly identified by the business, and may be submitted separately to facilitate identification and handling by EPA. If the business desires confidential treatment only until a certain date or until the occurrence of a certain event, the notice should so state.”

If no business confidentiality claim accompanies the information when it is received by EPA, EPA may make the information available to the public without further notice.

You may claim as confidential all information included in the response to a question by checking the Confidential Business Information (CBI) box next to each question number for which responses contain CBI. Alternatively, all questions in this survey marked with a CBI check box may be claimed confidential now by checking the box at the end of this paragraph. If you do not check this box, any individual response where “CBI” is **NOT** checked will be considered nonconfidential. Note that you may be required to justify any claim of confidentiality at a later time. Note also that plant effluent data are not eligible for confidential treatment, pursuant to Section 308(b) of the Clean Water Act, and thus will be treated as nonconfidential even if the “all CBI” box is checked.

All Eligible Data are CBI

Information covered by a claim of confidentiality will be disclosed by EPA only to the extent of, and by means of, the procedures set forth in 40 CFR Part 2, Subpart B. In general, submitted information protected by a business confidentiality claim may be disclosed to other employees, officers, or authorized representatives of the United States concerned with implementing the Clean Water Act.

Information covered by a claim of confidentiality will be made available to EPA contractors under EPA Contract Numbers 68-C-99-263, 68-C-99-233, 68-C-98-139, 68-C6-0022, and 68-C4-99-242 to enable the contractors to perform the work required by their contracts with EPA. All EPA contracts provide that contractor employees use the information only for the purpose of performing the work required by their contracts and will not disclose any CBI to anyone other than EPA without prior written approval from each affected business or from EPA’s legal

office. Any comments you may wish to make on this issue must be submitted in writing along with your completed survey.

WHERE TO RETURN THE SURVEY

After completing the survey and certifying the information that it contains, use the enclosed mailing label to mail the completed survey to:

U.S. Environmental Protection Agency
2001 Meat Products Industry Survey
c/o Westat
1650 Research Blvd.
Rockville, MD 20850-9973

Retain a copy of the completed survey, including attachments. EPA will review the information submitted and may request your cooperation in answering follow-up questions, if necessary, to complete our analyses.

CERTIFICATION STATEMENT

Was your site engaged in full-time, part-time or intermittent meat product operations during 1999? (For purposes of this survey, meat product operations include red meat and poultry slaughtering operations, by-product operations, rendering, and further processing.)

- G Yes (Complete the survey; **sign Certification Statement #1** below when survey has been completed)
- G No (Sign Certification Statement #2 below and return the following to EPA at the given address: Pages iii and iv and the cover page containing the site address label)

When the survey has been completed or "No" has been checked above, the individual responsible for directing or supervising the preparation of this survey must read and sign the appropriate Certification Statement listed below. The certifying official must be a responsible corporate official or his/her authorized representative.

Certification Statement #1

I certify under penalty of law that the enclosed survey response was prepared under my direction or supervision in accordance with a system designed to assure that qualified personnel properly gathered and evaluated the information submitted. The information submitted is, to the best of my knowledge and belief, accurate and complete. In those cases where we did not possess the requested information, we provided best engineering estimates in response to the questions. I am aware that there are significant penalties for submitting false information, including the possibility of fines and imprisonment as explained in Section 308 of the Clean Water Act.

Signature of Certifying Official

Date

Printed Name of Certifying Official

()

Telephone Number

Title of Certifying Official

Certification Statement #2

I certify under penalty of law that this site did not engage in meat product operations during 1999. I am aware that there are significant penalties for submitting false information, including the possibility of fines and imprisonment as explained in Section 308 of the Clean Water Act.

If you are certifying that your site is not engaged in meat product operations, indicate the classification of your site.

- G Office
- G Distribution
- G Other (specify): _____

Signature of Certifying Official

Date

Printed Name of Certifying Official

()

Telephone Number

Title of Certifying Official

GENERAL INSTRUCTIONS

Complete this survey for your entire site. A site is one contiguous physical location at which meat product processes occur. In some instances, a site may include properties located within separate fence lines, but located close to each other.

Mark responses for each question. Fill in the appropriate response(s) to each question. Use **black ink** or **type** in the spaces provided. If the space allowed for the answer to any question is inadequate for your complete response, continue the response in the Comments area at the end of the survey, cross-referencing the appropriate section and question number. If additional attachments are required to clarify a response, place the associated question number and your site ID number (shown on the cover page) in the upper right corner of each page of the attachments.

Answer all questions unless instructed otherwise. The purpose of this survey is to gather necessary information pertinent to meat product processes. Answer the questions in sequence unless you are directed to SKIP. Report only whole numbers, unless instructed otherwise. If a particular part of the required information is not applicable to your site, enter "NA" rather than leaving the answer blank. Enter zero where appropriate. Do not leave an entry blank if the answer is zero. As noted throughout the survey, you are required to provide best engineering estimates when data are not readily available. If you provide an estimate, note the basis for the estimates on the Comments page at the end of the survey. EPA does not intend for sites to conduct detailed studies to obtain the data. If you feel you need to conduct a detailed study, please call the Technical Information Help Line at (888) 296-5146 or email your questions to EPAMeatProductsSurvey@Westat.com.

Some PAGES in the survey will likely need to be photocopied before you respond. Indicate how many copies of the page you are submitting by completing the entry "Copy _____ of _____" in the top right corner.

Pay close attention to the measurement units requested (e.g., gallons, pounds) in each question. Be careful to provide data in the requested units, where available, or note where alternate units are used.

Retain a copy of the completed survey for your records. EPA will review the information submitted and may request, if necessary, your cooperation in answering follow-up clarification questions to complete the data collection effort. Retain a copy of the completed survey, including attachments, in case you (i.e., the contact identified in Question 4) are contacted to clarify your responses. Also, please maintain a record of sources used to complete the questions.

Refer to the Definitions Section for terms which are used in this survey.

If you have any comments on a question or you feel an answer needs clarification, use the Comments page at the end of the survey. Be sure to cross-reference your comments by question number.

Indicate information which should be treated as confidential by checking the Confidential Business Information (CBI) box next to each question number with responses containing CBI, or you may designate all eligible information as CBI by using the global CBI check-off box on page ii. If you do not use the global CBI check-off box, any response where "CBI" is not individually checked will be considered nonconfidential. Refer to the instructions given in the PROVISIONS REGARDING DATA CONFIDENTIALITY section on page ii for additional information regarding EPA's confidentiality procedures set forth in 40 CFR Part 2, Subpart B. The individual CBI boxes begin with Question 8.

DEFINITIONS

GENERAL DEFINITIONS

Blood Processing. The blood may be heated to coagulate the albumin; then, the albumin and fibrin are separated (e.g., with a screen or centrifuge) from the blood water and forwarded for further processing. The blood water or serum remaining after coagulation may be evaporated for animal feed, or it may be sewered.

Deep-Well Injection. Long-term or permanent disposal of untreated, partially treated, or treated wastewaters by pumping the wastewater into underground formations of suitable character through a bored, drilled, or driven well.

Effluent Limitations Guidelines and Standards. Regulations promulgated by U.S. EPA under authority of Sections 301, 304, 306, and 307 of the Clean Water Act that set out minimum, national technology-based standards of performance for point source wastewater discharges from specific industrial categories (e.g., iron and steel manufacturing plants). Effluent limitations guidelines and standards regulations are implemented through the NPDES permit and national pretreatment programs and include the following:

- Best Practicable Control Technology Currently Available (BPT)
- Best Available Technology Economically Achievable (BAT)
- Best Conventional Pollutant Control Technology (BCT)
- New Source Performance Standards (NSPS)
- Pretreatment Standards for Existing Sources (PSES)
- Pretreatment Standards for New Sources (PSNS)

The pretreatment standards (PSES, PSNS) are applicable to industrial facilities with process wastewater discharges to publicly owned treatment works (POTWs). The effluent limitations guidelines and new source performance standards (BPT, BAT, BCT, and NSPS) are applicable to industrial facilities with direct discharges of process wastewaters to waters of the United States.

Ground Water. Water in a saturated zone or stratum beneath the surface of land or water.

Live Weight Killed (LWK). The total weight of the total number of animals slaughtered during the time to which the effluent limitations apply; i.e., during any one day or any period of thirty consecutive days.

Meat Product Operations. Include red meat and poultry slaughtering operations, by-product operations, rendering, and further processing.

Noncontact Cooling Water. Water used for cooling in process and nonprocess applications which does not come into contact with any raw material, intermediate product, by-product, waste product (including air emissions), or finished product.

NPDES Program. The National Pollutant Discharge Elimination System (NPDES) program authorized by Sections 307, 318, 402, and 405 of the Clean Water Act which applies to facilities that discharge wastewater directly to United States surface waters.

Privately Owned Treatment Works (PrOTWs). Any device or system owned and operated by a private entity and used for storage, treatment, recycling, or reclamation of liquid industrial wastes.

Process Wastewater. Any water which, during red meat or poultry operations, comes into direct contact with or results from the storage, production, or use of any raw material, intermediate product, finished product, by-product, or waste product. Wastewater from equipment cleaning, direct-contact air pollution control devices, rinse water, storm water associated with industrial activity, and contaminated cooling water are considered process wastewater. Process wastewater may also include wastewater that is contract hauled for off-site disposal. Sanitary wastewater, uncontaminated noncontact cooling water, and storm water not associated with industrial activity are not considered process wastewater.

Publicly Owned Treatment Works (POTWs). Any device or system owned and operated by a public entity and used in the storage, treatment, recycling, or reclamation of liquid municipal sewage and/or liquid industrial wastes. The sewerage system that conveys wastewaters to treatment works is considered part of the POTW.

Site. A site is generally one contiguous physical location at which manufacturing operations related to the meat products industry occur. This includes, but is not limited to, slaughtering, processing, and rendering. In some instances, a site may include properties located within separate fence lines, but located close to each other.

Surface Water. Waters of the United States as defined at 40 CFR 122.2.

Wastewater. See Process Wastewater.

Wastewater Treatment. The processing of wastewater by physical, chemical, biological, or other means to remove specific pollutants from the wastewater stream or to alter the physical or chemical state of specific pollutants in the wastewater stream. Treatment is performed for discharge of treated wastewater, recycle of treated wastewater to the same process which generated the wastewater, or for reuse of the treated wastewater in another process.

Zero Discharge or Alternative Disposal Methods. Disposal of process and/or nonprocess wastewaters other than by direct discharge to a surface water or by indirect discharge to a POTW or PrOTW. Examples include land application, deep well injection, and contract hauling.

RED MEAT DEFINITIONS

Canned Meat Processor. (Definition for 40 CFR 432, Subpart I) An operation which prepares and cans meats (such as stew, sandwich spreads, or similar products) alone or in combination with other finished products at rates greater than 2730 kg (6000 lb) per day.

Complex Slaughterhouse. (Definition for 40 CFR 432, Subpart B) A slaughterhouse that accomplishes extensive by-product processing, usually at least three of such operations as rendering, paunch and viscera handling, blood processing, hide processing, or hair processing.

Dry Rendering. The process of cooking animal byproducts by dry heat in open steam-jacketed tanks.

Finished Product. (Definition for Table 10.1) The final manufactured product produced on site, including products intended for consumption with no additional processing as well as products intended for further processing, when applicable.

First Processing. Operations which receive live red meat animals and produce a raw, dressed red meat product, either whole or in parts.

Further Processing. Operations which utilize whole or cut-up meat products for the production of cooked, canned, ground, chopped, diced, or breaded fresh or frozen products.

Ham Processor. (Definition for 40 CFR 432, Subpart H) An operation which manufactures hams alone or in combination with other finished products at rates greater than 2730 kg (6000 lb) per day.

Hide Processing. Wet or dry hide processing. Includes demanuring, washing, and defleshing, followed by curing.

High-Processing Packinghouse. (Definition for 40 CFR 432, Subpart D) A packinghouse which processes both animals slaughtered at the site and additional carcasses from outside sources.

Low-Processing Packinghouse. (Definition for 40 CFR 432, Subpart C) A packinghouse that processes no more than the total animals killed at that plant, normally processing less than the total kill.

Meat Cutter. (Definition for 40 CFR 432, Subpart F) An operation which fabricates, cuts, or otherwise produces fresh meat cuts and related finished products from livestock carcasses, at rates greater than 2730 kg (6000 lb) per day.

Packinghouse. A plant that both slaughters animals and subsequently processes carcasses into cured, smoked, canned or other prepared meat products.

Red Meat. The term "red meat" includes all animal products from cattle, calves, hogs, sheep and lambs, etc., except those defined as Poultry.

Red Meat Operations. Includes red meat slaughtering operations, by-product operations, rendering, and further processing.

Renderer. (Definition for 40 CFR 432, Subpart J) An independent or off-site rendering operation, conducted separate from a slaughterhouse, packinghouse, or poultry dressing or processing plant, which manufactures at rates greater than 75,000 pounds of raw material per day of meat meal, tankage, animal fats or oils, grease, and tallow, and may cure cattle hides, but excluding marine oils, fish meal, and fish oils.

Simple Slaughterhouse. (Definition for 40 CFR 432, Subpart A) A slaughterhouse which accomplishes very limited by-product processing, if any, usually no more than two of such operations as rendering, paunch and viscera handling, blood processing, hide processing, or hair processing.

Sausage and Luncheon Meat Processor. (Definition for 40 CFR 432, Subpart G) An operation which cuts fresh meats, grinds, mixes, seasons, smokes, or otherwise produces finished products such as sausage, bologna, and luncheon meats at rates greater than 2730 kg (6000 lb) per day.

Slaughterhouse. A plant that slaughters animals and has as its main product fresh meat as whole, half, or quarter carcasses or smaller meat cuts.

Small processor. (Definition for 40 CFR 432, Subpart E) An operation that produces up to 2730 kg (6000 lb) per day of any type or combination of finished products.

Viscera Handling. Wet or dry viscera handling. Includes removal of partially digested feed and washing of viscera.

Wet Rendering. The process of cooking animal byproducts by steam under pressure in closed tanks.

POULTRY DEFINITIONS

Dry Rendering. The process of cooking animal byproducts by dry heat in open steam-jacketed tanks.

Finished Product. (Definition for Table 12.1) The final manufactured product produced on site, including products intended for consumption with no additional processing as well as products intended for further processing, when applicable.

First Processing. Operations which receive live poultry and produce a raw, dressed poultry product, either whole or in parts.

Further Processing. Operations which receive dressed poultry (whole, cut up or deboned) for the production of cooked, canned, ground, chopped, diced, breaded, stuffed, fresh, or frozen products.

Poultry. Broilers, other young chickens, hens, fowl, mature chickens, turkeys, capons, geese, ducks, and small game such as quail, pheasants, and rabbits.

Poultry Operations. Includes poultry slaughtering operations, by-product operations, rendering, and further processing.

Renderer. (Definition for 40 CFR 432, Subpart J) An independent or off-site rendering operation, conducted separate from a slaughterhouse, packinghouse, or poultry dressing or processing plant, which manufactures at rates greater than 75,000 pounds of raw material per day of meat meal, tankage, animal fats or oils, grease, and tallow, and may cure cattle hides, but excluding marine oils, fish meal, and fish oils.

Wet Rendering. The process of cooking animal byproducts by steam under pressure in closed tanks.

FACILITY INFORMATION

1. If the site mailing address shown on the cover page is correct, check () the box below. If it is not the correct address for this site, provide the correct site name and address in the spaces provided below.

G Address on cover page is correct **(Skip to Question 2)**

_____ Company Name	_____ Site Address or P.O. Box
_____ Subsidiary Name (if any)	_____ Site Address continued
_____ Site or Plant Name	_____ City
	_____ State
	_____ ZIP Code

2. If the street (i.e., physical) address of your site is different from the mailing address on the cover page or given in Question 1, provide the street address in the spaces provided below. If the mailing address and street address are the same, check () the box below.

G Address on cover page or response to Question 1 is physical address.

_____ Street Address	_____ City
_____ Street Address continued	_____ State
	_____ ZIP Code

3. What is the name and address of the company that owns this site?

Name of Company _____
Mailing Address or P.O. Box _____
City _____ State _____ ZIP _____

4. Provide the names, titles, telephone numbers, and facsimile numbers of the technical and financial contacts at your site for information supplied in this survey.

_____ Technical Contact Name	_____ Financial Contact Name
_____ Technical Contact Title	_____ Financial Contact Title
(_____) _____ Telephone Number	(_____) _____ Telephone Number
(_____) _____ Facsimile Number	(_____) _____ Facsimile Number

5. What year did operations begin at your site? If unknown, estimate the date to the nearest year. Operations are any processes related to the meat products industry and not necessarily operations as they are currently performed. Operations at the site may have begun under other ownership.

Year Operations Began

6. Please list up to three primary, secondary, and other Standard Industrial Classification (SIC) codes or North American Industry Classification System (NAICS) codes which apply to the operations performed at your facility in 1999. (See Appendix B for listing of codes.)

(Primary) (Secondary) (Other) (Other) (Other)

7. Is this site operated under:

- Federal Inspection ¹ G
 - Federal-State Cooperative Inspection ² G
 - State Inspection ³ G
 - Other (please explain) ⁴ G
-
- Not Applicable ⁵ G

8. Does this site file annual reports with the USDA, Grain Inspection, Packers and Stockyards Administration?

G CBI

- Yes ¹ G
- No ² G

PRODUCTION INFORMATION

9. Effluent limitations guidelines and pretreatment standards for the Meat Products Point Source Category are presented at 40 CFR Part 432. Subcategories A through I of 40 CFR Part 432 apply only to Red Meat Operations. Subcategory J of 40 CFR Part 432 applies to both Red Meat and Poultry Operations. Based upon your facility's 1999 operations, would your facility be classified under a Subcategory of 40 CFR Part 432? Definitions for these Subcategories are provided in the Definitions Section of this survey. (Please note that facilities that discharge indirectly to a POTW are classified in a Subcategory of 40 CFR Part 432, even though there are currently no pretreatment standards for new or existing sources.) Check all that apply.

- Yes, Identify Meat Product Subcategory in 40 CFR 432 ¹ G
- a. Simple Slaughterhouse Subcategory ² G
- b. Complex Slaughterhouse Subcategory ³ G
- c. Low-Processing Packinghouse Subcategory ⁴ G
- d. High-Processing Packinghouse Subcategory ⁵ G
- e. Small Processor Subcategory ⁶ G
- f. Meat Cutter Subcategory ⁷ G
- g. Sausage and Luncheon Meats Subcategory ⁸ G
- h. Ham Processor Subcategory ⁹ G
- i. Canned Meats Subcategory ¹⁰ G
- j. Renderer Subcategory (**Note: Applicable to independent or off-site rendering operations only.**) ¹¹ G
- No ¹² G (Skip to Q.11)

- 10.(a)(1) During 1999, did your facility slaughter or "further process" any type of **Red Meat**?
G CBI

- a. Yes, slaughtered only ¹ G
- b. Yes, slaughtered and further processed red meat from on-site slaughtering ² G
- c. Yes, slaughtered and further processed red meat from both on-site and off-site slaughtering ³ G
- d. Yes, further processed red meat slaughtered off site ⁴ G
- e. No ⁵ G

(a)(2) During 1999, did your facility render any type of animal by-products (including Red Meat and Poultry by-products)?

G CBI

- a. Yes, rendered animal by-products from on-site operations only ¹ G
- b. Yes, rendered animal by-products from both on-site and off-site operations ² G
- c. Yes, rendered animal by-products from off-site operations only
(Note: you should have checked 9J above and you should complete
Table 10.3 below) ³ G
- d. No ⁴ G

(a)(3) In 1999, how many days did your facility operate (applies to operations classified under 40 CFR Part 432 only)?

G CBI

Number of days

10.(a)(4) Please complete Table 10.1 in either pounds or kilograms for **Red Meat Operations** in 1999. (In the event that exact production records or data are not available, provide best engineering estimates and note the basis for the estimates on the Comments page located at the end of the survey.) **Skip to Question 10c if you indicated only Subpart J in Question 9 above.**
G CBI

TABLE 10.1 Values in (Please check one): G 1000 Pounds
G 1000 Kilograms

Type of Meat Product	Cattle	Calves	Hogs	Sheep and Lambs	Other (Specify _____)
Animals Slaughtered on Site [as LWK]					
Carcasses, Animal Parts, or By-Products Received from Off Site for Processing					
All By-Product Operations (includes by-products received from off site for rendering or processing)					
Weight of blood rendered on site					
Weight of hides processed on site					
Weight of hair rendered on site					
Weight of offal rendered on site					
Weight of skimmings rendered on site					
Weight of total by-products to wet or low temperature rendering on site					
Weight of total by-products to dry rendering on site					
All Finished Products Produced On Site					
Weight of whole carcasses as a finished product					
Weight of cut-up carcasses as a finished product					
Weight of other finished products (Please describe in comments section)					

Type of Meat Product	Cattle	Calves	Hogs	Sheep and Lambs	Other (Specify _____)
Byproducts Produced On Site and Sent Off Site for Rendering					
Weight of blood					
Weight of hides					
Weight of hair					
Weight of offal					
Weight of skimmings					
Weight of other byproducts					

10.(b) As you indicated in Question 9 above, if your facility is classified under Subcategory E, F, G, H, or I of 40 CFR Part 432, please complete Table 10.2 in **either pounds or kilograms**. For this question, use the following definitions for “finished product,” as appropriate. **(Applies to Red Meat Operations Only.)** Complete one line for each applicable Subcategory.

G CBI

Finished product. (Definition for 40 CFR Part 432, Subpart E) The final manufactured product as fresh meat cuts, hams, bacon or other smoked meats, sausage, luncheon meats, stew, canned meats, or related products.

Finished product. (Definition for 40 CFR Part 432, Subpart F) The final manufactured product as fresh meat cuts including, but not limited to, steaks, roasts, chops, or boneless meats.

Finished product. (Definition for 40 CFR Part 432, Subpart G) The final manufactured product as fresh meat cuts including steaks, roasts, chops, or boneless meat, bacon or other smoked meats (except hams) such as sausage, bologna or other luncheon meats, or related products (except canned meats).

Finished product. (Definition for 40 CFR Part 432, Subpart H) The final manufactured product as fresh meat cuts including steaks, roasts, chops, or boneless meat, smoked or cured hams, bacon or other smoked meats, sausage, bologna or other luncheon meats (except canned meats).

Finished product. (Definition for 40 CFR Part 432, Subpart I) The final manufactured product as fresh meat cuts including steaks, roasts, chops, or boneless meat, hams, bacon or other smoked meats, sausage, bologna or other luncheon meats, stews, sandwich spreads or other canned meats.

TABLE 10.2

Meat Product Subcategory in 40 CFR 432 (Check One)	Product Type	1000 kg of Finished Product in 1999	OR	1000 lb of Finished Product in 1999
G E	Specify _____			
G F	Specify _____			
G G	Specify _____			
G H	Specify _____			
G I	Specify _____			

10.(c) As you indicated in Question 9 above, if your facility is classified under Subcategory J (Renderer) of 40 CFR Part 432, please complete Table 10.3 in **either pounds or kilograms (applies to Red Meat and Poultry Operations)**. (In the event that exact production records or data are not available, provide best engineering estimates and note the methods that were used to make the estimates on the Comments page located at the end of the survey.) For this question, the following definition for “raw material” applies:

G CBI

Raw Material. (Definition for 40 CFR Part 432, Subpart J, Table 10.3) The basic input materials to a renderer composed of animal and poultry trimmings, bones, meat scraps, dead animals, feathers, and related usable by-products.

TABLE 10.3

Meat Product Subcategory in 40 CFR Part 432	Type of Raw Material and Type of Animal as Source of Raw Material	1000 kg of Raw Material in 1999	OR	1000 lb of Raw Material in 1999
J – Renderer	Raw Material _____ Animal Type _____			
	Raw Material _____ Animal Type _____			
	Raw Material _____ Animal Type _____			
	Raw Material _____ Animal Type _____			
	Raw Material _____ Animal Type _____			
	Raw Material _____ Animal Type _____			
	Raw Material _____ Animal Type _____			

11(a). During 1999, did your facility slaughter or “further process” any type of **Poultry**?
G CBI

- a. Yes, slaughtered only ¹ G
- b. Yes, slaughtered and further processed poultry slaughtered on-site ² G
- c. Yes, slaughtered and further processed poultry from both on-site and off-site slaughtering ³ G
- d. Yes, further processed poultry slaughtered off site ⁴ G
- e. No ⁵ G **(Skip to Q.13)**

11(b). In 1999, how many days did your facility operate (**applies to Poultry Operations not covered under 40 CFR Part 432 only**)?

G CBI

Number of days

12. Please complete Table 12.1 in either pounds or kilograms for **Poultry Operations** at your facility in 1999. (In the event that exact data are not available, provide best engineering estimates and note the basis for the estimates on the Comments page located at the end of the survey.) If you are an independent or off-site rendering operation, as defined in 40 CFR Part 432, you should have presented your facility's information in Table 10.3 and you do not need to complete Table 12.1 below.

G CBI

TABLE 12.1 Values in (Please check one): G 1000 Pounds
G 1000 Kilograms

Type of Meat Product	Broilers and Other Young Chickens	Hens (or Fowl) and Other Chickens	Turkeys	Other Poultry and Small Game (Specify_____)
Poultry Slaughtered On Site (First Processing LWK)				
Dressed Poultry Produced On Site for Further Processing				
Dressed Poultry Received from Off Site for Further Processing				
All By-Product Operations (Poultry Rendering)- Complete only for rendering that occurs at this facility				
Weight of feathers from on site first processing				
Weight of feathers from off site facilities				
Weight of offal from on site first processing				
Weight of offal form off site facilities				
Weight of skimmings from on site first processing				
Weight of skimmings from off site facilities				

Type of Meat Product	Broilers and Other Young Chickens	Hens (or Fowl) and Other Chickens	Turkeys	Other Poultry and Small Game (Specify_____)
Weight of blood from on site first processing				
Weight of blood from off site facilities				
Weight of other byproducts from on site first processing				
Weight of other byproducts from off site				
Weight of total by-products to wet or low temperature rendering on site				
Weight of total by-products to dry rendering on site				
All Finished Products Produced On Site				
Weight of dressed poultry, whole				
Weight of dressed poultry, parts				
Weight of deboned meat, raw				
Weight of further processed, raw or cooked				
Weight of other finished products (please describe in comments section)				
Byproducts Produced On Site and Sent Off Site for Rendering				
Weight of feathers				
Weight of blood				
Weight of offal				
Weight of skimmings				
Weight of other byproducts				

WASTEWATER INFORMATION

- 13.(a)** Please identify the type(s) and quantity of process wastewater generated at your facility for **Red Meat Operations** in 1999. Indicate all that apply. (In the event that exact data are not available, provide best engineering estimates and note the methods that were used to make the estimates on the Comments page located at the end of the survey.) **Note: Please see definitions for Red Meat Operations and for process wastewater in Definitions section.**

G CBI

Disposal Method Codes:

- 1 - Discharged to a surface water under an NPDES permit
- 2 - Discharged to publicly owned treatment works (POTW)
- 3 - Land applied on site
- 4 - Surface impoundment on site (as final disposal)
- 5 - Transferred to an off-site commercial waste treatment facility
- 6 - Transferred to an off-site intracompany wastewater treatment facility
- 7 - Other (Please specify _____)

Red Meat Operations

Check All That Apply	Code for PFDs in Question 21 Below	Type of Process Wastewater	Gallons/Year	Treated on Site? (Yes or No)	Final Disposal Method (Code from above)
G		None			
G	R1	Process wastewater generated from animal pens		<input type="checkbox"/> Yes <input type="checkbox"/> No	
G	R2	Process wastewater generated from killing and bleeding operations		<input type="checkbox"/> Yes <input type="checkbox"/> No	
G	R3	Process wastewater generated from hide removal operations		<input type="checkbox"/> Yes <input type="checkbox"/> No	
G	R4	Process wastewater generated from evisceration operations		<input type="checkbox"/> Yes <input type="checkbox"/> No	
G	R5	Process wastewater generated from paunch operations		<input type="checkbox"/> Yes <input type="checkbox"/> No	
G	R6	Process wastewater generated from scalding and hair removal operations		<input type="checkbox"/> Yes <input type="checkbox"/> No	
G	R7	Process wastewater generated from meat washing operations		<input type="checkbox"/> Yes <input type="checkbox"/> No	
G	R8	Process wastewater generated from rendering operations [please specify type(s) of rendering (e.g., wet or dry) _____]		<input type="checkbox"/> Yes <input type="checkbox"/> No	
G	R9	Process wastewater generated from cutting operations		<input type="checkbox"/> Yes <input type="checkbox"/> No	

Check All That Apply	Code for PFDs in Question 21 Below	Type of Process Wastewater	Gallons/Year	Treated on Site? (Yes or No)	Final Disposal Method (Code from above)
G	R10	Process wastewater generated from further processing operations (e.g., thaw tanks, cooking vats, cooling tanks)		<input type="checkbox"/> Yes <input type="checkbox"/> No	
G	R11	Process wastewater generated from clean-up operations		<input type="checkbox"/> Yes <input type="checkbox"/> No	
G	R12	Process wastewater generated from rendering plant condensate and condensor water		<input type="checkbox"/> Yes <input type="checkbox"/> No	
G	R13	Process wastewater from truck washing		<input type="checkbox"/> Yes <input type="checkbox"/> No	
G	R14	Stormwater runoff from meat product activity area		<input type="checkbox"/> Yes <input type="checkbox"/> No	
G	R15	Other--Please specify _____		<input type="checkbox"/> Yes <input type="checkbox"/> No	
G	R16	Other--Please specify _____		<input type="checkbox"/> Yes <input type="checkbox"/> No	
G	R17	Other--Please specify _____		<input type="checkbox"/> Yes <input type="checkbox"/> No	

13.(b) Please identify the type(s) and quantity of wastewater generated at your facility for **Poultry Operations** in 1999. Indicate all that apply. (In the event that exact data are not available, provide best engineering estimates and note the methods that were used to make the estimates on the Comments page located at the end of the survey.) **Note: Please see definitions for poultry operations and for process wastewater in Definitions section.**

G CBI

Poultry Operations

Check All That Apply	Code for PFDs in Question 21 Below	Type of Process Wastewater	Gallons/Year	Treated on Site? (Yes or No)	Final Disposal Method (Code from Q. 13(a) above)
G		None			
G	P1	Process Wastewater from Live Receiving		<input type="checkbox"/> Yes <input type="checkbox"/> No	
G	P2	Process Wastewater from Killing		<input type="checkbox"/> Yes <input type="checkbox"/> No	
G	P3	Process Wastewater from Bleeding		<input type="checkbox"/> Yes <input type="checkbox"/> No	
G	P4	Process Wastewater from Scalding		<input type="checkbox"/> Yes <input type="checkbox"/> No	

Check All That Apply	Code for PFDs in Question 21 Below	Type of Process Wastewater	Gallons/Year	Treated on Site? (Yes or No)	Final Disposal Method (Code from Q. 13(a) above)
G	P5	Process Wastewater from Defeathering		<input type="checkbox"/> Yes <input type="checkbox"/> No	
G	P6	Process Wastewater from Whole Bird Wash		<input type="checkbox"/> Yes <input type="checkbox"/> No	
G	P7	Process Wastewater from Evisceration		<input type="checkbox"/> Yes <input type="checkbox"/> No	
G	P8	Process Wastewater from Final Bird Wash		<input type="checkbox"/> Yes <input type="checkbox"/> No	
G	P9	Process Wastewater from Chilling		<input type="checkbox"/> Yes <input type="checkbox"/> No	
G	P10	Process Wastewater from Cut-up		<input type="checkbox"/> Yes <input type="checkbox"/> No	
G	P11	Process Wastewater from Packaging		<input type="checkbox"/> Yes <input type="checkbox"/> No	
G	P12	Process Wastewater from Deboning Operations		<input type="checkbox"/> Yes <input type="checkbox"/> No	
G	P13	Process Wastewater from Injection/Marination Operations		<input type="checkbox"/> Yes <input type="checkbox"/> No	
G	P14	Process Wastewater from Breeding/Batter Operations		<input type="checkbox"/> Yes <input type="checkbox"/> No	
G	P15	Process Wastewater from Cooking Operations		<input type="checkbox"/> Yes <input type="checkbox"/> No	
G	P15	Process Wastewater from Offal Rendering/Condensing		<input type="checkbox"/> Yes <input type="checkbox"/> No	
G	P16	Process Wastewater from Feather Rendering/Condensing		<input type="checkbox"/> Yes <input type="checkbox"/> No	
G	P17	Process Wastewater from Other Rendering/Condensing		<input type="checkbox"/> Yes <input type="checkbox"/> No	
G	P18	Stormwater Runoff from Manufacturing Areas		<input type="checkbox"/> Yes <input type="checkbox"/> No	
G	P19	Other--Please specify_____		<input type="checkbox"/> Yes <input type="checkbox"/> No	
G	P20	Other--Please specify_____		<input type="checkbox"/> Yes <input type="checkbox"/> No	
G	P21	Other--Please specify_____		<input type="checkbox"/> Yes <input type="checkbox"/> No	

TREATMENT INFORMATION

- 14.(a)** Please identify all types of on-site treatment processes (a list of common treatment processes for the meat products industry is provided on the next page) used to treat the process wastewater stream(s) identified in Item 13. Please indicate all applicable processes utilized at the site. If a treatment process is used that is not listed below, or if a unique variation of a listed treatment process is used, please provide specific details in the response. (Also note that Question 20 below requests the submission of a process flow diagram of the wastewater treatment processes at your facility.)

G CBI

_____	_____
_____	_____
_____	_____
_____	_____
_____	_____
_____	_____
_____	_____
_____	_____

- (b)** Are any of these wastewater treatment processes listed in 14(a) used for nutrient removal?

G CBI

Yes ¹ G
(Specify which ones _____)
No ² G

- (c)** Do you use trisodium phosphate as a treatment chemical in your wastewater treatment system?

G CBI

Yes ¹ G
No ² G

- (d)** For the wastewater treatment operations described above, please attach any readily available information for 1999 on:

G CBI

- I. the design specifications (e.g. design flow, removal efficiencies)
- ii. operating capacities, and
- iii. costing information (i.e., total costs for construction and operation and maintenance costs).

Please note that EPA is not soliciting detailed and voluminous design specifications and cost information, but instead desires general information related to the design and operation of the wastewater treatment system.

Treatment Processes

Primary Treatment

Screening
Flow Equalization
pH Adjustment
Grease Recovery System

- Catch Basin
- Wet Well
- Sump

Dissolved Air Flotation
Dissolved Air Flotation (with Chemical Coagulation)
Electrocoagulation

Biological Wastewater Treatment Systems

Lagoons (Stabilization Ponds)

- Anaerobic (Facultative)
- Aerobic (Oxidation)
- Aerated

Activated Sludge

- Conventional
- Oxidation Ditch
- Extended Aeration
- Step Aeration
- Contact Stabilization
- Sequencing Batch Reactor

Trickling Filter
Rotating Biological Contactors

Biosolids Processing

Thickening

- Gravity thickening
- Air Flotation
- Centrifugation

Stabilization

- Anaerobic Digestion
- Aerobic Digestion
- Heat Treatment

Dewatering

- Vacuum Filtration
- Drying Beds
- Filter Press
- Centrifugation

Other/Advanced Wastewater Treatment

Clarification

- Primary
- Secondary
- With Chemical Coagulation

Neutralization
Chemical Precipitation
Filtration

- Sand
- Mixed-Media
- Packed Bed
- Filter Cloth

Microscreen/Microstrainer

Other/Advanced Wastewater Treatment (cont.)

Nitrogen Control

- Nitrification
- Nitrification/Denitrification
- Ammonia Stripping
- Breakpoint Chlorination
- Chemical Oxidation

Disinfection

- Chlorine
- Ozone
- Ultraviolet Light

Spray/Flood Irrigation
Ion Exchange
Carbon Adsorption
Reverse Osmosis
Electrodialysis
Evaporation

17. How many discharge locations (outfalls) and other permit monitoring locations are present at this site? Include discharge locations discharging to surface waters, publicly owned treatment works (POTWs), and privately owned treatment works (PrOTWs).

G CBI

Number of locations

For each discharge location (outfall), complete one row of this table by providing the site designation of the outfall, the type(s) of wastewater discharged, and the discharge destination (e.g., river, POTW). If you need space for additional outfalls, please photocopy this page before completing it. For discharges regulated under an NPDES permit (or equivalent State discharge permit), use the outfall designations specified in the permit (e.g. 001, 002, etc.). For discharges to POTWs or PrOTWs, use applicable outfall designations provided by the POTW or PrOTW. If no outfall designation exists for the discharge, please indicate "None" in the first column of this table.

Outfall Designation	Type(s) of Wastewater	Discharge Destination
	G Process Wastewater (Other Than Stormwater Associated with Industrial Activity) G Landfill Leachate G Sanitary Wastewater G Ground Water G Noncontact Cooling Water G Stormwater Associated with Industrial Activity G Stormwater Not Associated with Industrial Activity G Other: _____	
	G Process Wastewater (Other Than Stormwater Associated with Industrial Activity) G Landfill Leachate G Sanitary Wastewater G Ground Water G Noncontact Cooling Water G Stormwater Associated with Industrial Activity G Stormwater Not Associated with Industrial Activity G Other: _____	
	G Process Wastewater (Other Than Stormwater Associated with Industrial Activity) G Landfill Leachate G Sanitary Wastewater G Ground Water G Noncontact Cooling Water G Stormwater Associated with Industrial Activity G Stormwater Not Associated with Industrial Activity G Other: _____	

Outfall Designation	Type(s) of Wastewater	Discharge Destination
	G Process Wastewater (Other Than Stormwater Associated with Industrial Activity) G Landfill Leachate G Sanitary Wastewater G Ground Water G Noncontact Cooling Water G Stormwater Associated with Industrial Activity G Stormwater Not Associated with Industrial Activity G Other: _____	

18.(a) Does your site discharge process wastewater by pipeline, sewer, or other discrete conveyance to surface water? (Please see definition of process wastewater in Definitions section of this survey.)

- Yes ¹G
- No ²G

(b) Does your site have a National Pollutant Discharge Elimination System (NPDES) permit or permits (or state-issued water discharge permit or permits) which authorize and/or regulate the discharge of process wastewaters, nonprocess wastewaters, or stormwater discharges?

- Yes ¹G
- Provide applicable permit number(s). (e.g., US1234567) below

 (Please attach a copy of your site's permit and fact sheet or statement of basis to the survey. Please include your site ID number, as shown on the cover page of this survey, in the upper right corner.)

- No ²G

19.(a) Indicate, if applicable, the type of facility to which your site discharges process wastewater by pipeline, sewer, or other conveyance. Check all that apply.

- Publicly owned treatment works (POTWs) ¹G
- Privately owned treatment works (PrOTWs) ²G
- Process waters are NOT discharged to a POTW or a PrOTW ³G **(Skip to Q.20)**

(b) Is the discharge of process wastewater, nonprocess wastewater, or stormwater regulated under a facility-specific control mechanism (e.g. permit, order or agreement) issued by a POTW or PrOTW?

Yes ¹G
Please provide:

Site Discharge Permit, Order or Agreement Number _____

Expiration Date (if applicable)_____

(Please attach a copy of your site's permit, order or agreement and fact sheet to the survey. Please include your site ID number, as shown on the cover page of this survey, in the upper right corner.)

No ²G

(c) If the discharge of process wastewater, nonprocess wastewater, or stormwater is subject to regulation under a local ordinance, please provide copies of the applicable portions of the local ordinance related to discharge (e.g., local limits, general and specific prohibitions, etc.)

(d) Provide the name, address, telephone number, and name of your contact at the POTW or PrOTW. Provide the permit number provided by the POTW or PrOTW and the expiration date (if applicable) and, if known, the NPDES permit number of the permit issued to the POTW or PrOTW.

Name of POTW or PrOTW _____

Street Address _____

City _____

State, Zip Code _____

Name of Contact _____

Telephone Number (_____)_____

Site Discharge Permit Number (if applicable) _____

Expiration Date (if applicable) _____

NPDES Permit Number of the POTW or PrOTW (if known) _____

20. Attach process flow diagrams (PFDs) to the survey. In order to understand your site's overall process, EPA is requiring that you include PFDs. Write the site ID number (shown on the cover page) on each diagram, and number each PFD in the upper right corner, starting with "PFD-1" and numbering each sequentially. More than one meat product process, wastewater treatment operation, and/or wastewater discharge location may be shown on the same PFD. If a PFD should be treated as confidential, stamp it "Confidential" or write "Confidential" or "CBI" across the top. If any diagram is not marked "Confidential," it will be considered nonconfidential under EPA's confidentiality procedures set forth in 40 CFR Part 2, Subpart B, unless you have checked the global CBI check-off box on page ii, in which case all PFDs will be treated as confidential. See Appendix B for examples of process flow diagrams.

G CBI

Specifically, attach one or more general process flow diagrams (PFDs) that show:
the production process(es) and the final products;
wastewater treatment operations; and
wastewater discharge locations.

You are **NOT** required to create a new PFD if an existing diagram will suffice. Number the diagrams in the upper right corner, and include your site ID number (as shown on the cover page). Specific instructions for including the PFD(s) are provided below.

Process and Wastewater Treatment Flow Diagrams Checklist

Be sure that...

- | | |
|--|---|
| All processes, wastewater treatment operations, and discharge locations (identified in Questions 14 and 17 above) on site are included. | G |
| The diagram of each production process includes the input of your starting materials (e.g., chickens, cattle), the flow of the meat products through the processes, and the final products shipped. | G |
| The diagram of each wastewater treatment process includes the types of process wastewater treated (using codes from Questions 13(a) and 13(b) above) and the final discharge location. | |
| All processes are labeled. | G |
| All products produced at your site are indicated and labeled. | G |
| The PFD number(s) and your site ID number have been written on each diagram(s). | G |
| If you believe that a diagram should be treated as confidential, stamp it "Confidential" or write "Confidential" or "CBI" across the top. If any diagram is not marked "Confidential," it will be considered nonconfidential under 40 CFR Part 2, Subpart B, unless you have checked the CBI check-off box on page ii, in which case all PFDs will be treated as confidential. | G |

-
21. Question 21 requires summary information for data collected by your site, including (1) monitoring data your site may have collected for permit monitoring requirements [Question 21.(a)], (2) any data collected simultaneously at both influent and effluent streams from a wastewater treatment system or a treatment unit [Question 21.(b)], and (3) any other wastewater characterization data collected at monitoring locations other than those specified in your permit [Question 21.(b)].

G CBI

Each part of this question requires you to assign a unique sampling point (SP) number to each sampling location and provide the SP number at the top of the table for each question. At the top of each table, provide (1) the entire wastewater treatment system (using treatment types identified in Question 14) from where the wastewater stream is an effluent and to where the stream is an influent, **OR** (2) the outfall to where the wastewater stream is discharged (e.g., Outfall 001 - Mill Creek). Check () the appropriate choice and provide the source and/or destination of the stream.

Each part of this question contains a table to specify the following information:

- The pollutant analyzed (using the Pollutant Parameter Codes shown on the following page);
- The EPA (or alternative) analytical method used;
- Whether the samples were collected as grabs or as composites;
- The total number of samples collected at that sampling point for that pollutant;
- The number of samples in which the pollutant was not detected;
- The typical detection limit or range of detection limits for that sampling point for that pollutant;
- The average concentration of the pollutant;
- The calculation methodology used to determine the average concentration when some or all measurements were not detected (see the following detailed description);
- The maximum concentration of the pollutant;
- The minimum concentration of the pollutant; and
- The average flow rate at this sampling point during the sampling period for that pollutant.

At the top of the table for Question 21(a) and 21(b), you are also required to provide the range of dates in which data were collected. Complete the table, one page per sampling point, one row per pollutant parameter. If you have provided these data elsewhere in the survey, do **NOT** repeat it in this question. Indicate that the data are provided elsewhere on the Comments page for this section.

Pollutant Parameter Codes

Pollutant Parameter Code	Pollutant Parameter Name	Pollutant Parameter Code	Pollutant Parameter Name
P-1	Acute Toxicity (ceriodaphmia)	P-16	Oil and Grease, Total Recoverable
P-2	Acute Toxicity (pimephales)	P-17	pH
P-3	Ammonia as Nitrogen	P-18	Soluble Reactive Phosphorus (as P)
P-4	Arsenic	P-19	Temperature
P-5	5-Day Biochemical Oxygen Demand (BOD ₅)	P-20	Total Kjeldahl Nitrogen
P-6	Carbonaceous Biochemical Oxygen Demand	P-21	Total Nitrogen ²
P-7	Chemical Oxygen Demand (COD)	P-22	Total Phosphorus (as P)
P-8	Chloride	P-23	Total Dissolved Solids (TDS)
P-9	Chromium	P-24	Total Reactive Phosphorus (as P)
P-10	Dissolved Oxygen	P-25	Total Residual Chlorine
P-11	Fecal Coliform	P-26	Total Suspended Solids (TSS)
P-12	Fecal Streptococci	P-27	Total Volatile Solids
P-13	Mercury	P-28	Other (specify): _____
P-14	Nitrate + Nitrite (as Nitrogen)	P-29	Other (specify): _____
P-15	Oil and Grease, HEM ¹	P-30	Other (specify): _____

¹ N-Hexane Extractable Material (HEM)

² Total Nitrogen is defined as the sum of TKN, Nitrate, and Nitrite.

Not Detected (ND) Calculation Method

To complete Questions 21(a) and 21(b), you are requested to provide the calculation (or a similar) method you used to calculate the average concentration of each pollutant parameter when some or all measurements were not detected (ND). Since laboratories may report pollutant parameters as ND, EPA expects that you will also use the NDs in the calculation of the average concentration. There are several methods which may be used to calculate an average pollutant parameter concentration when ND values have been reported by the laboratory. EPA requests that you identify which method you used to calculate an average pollutant parameter concentration. The following is a description of the different types of detection limits, the ND calculation methods, and examples:

- The method detection limit is the detection limit set by the analytical methods in 40 CFR Part 136; if an alternative method was used, please specify the method and detection limit.
- The sample detection limit is the detection limit set by the matrix complexity and reported to you by the laboratory.

In calculating an average pollutant concentration, the following methods of including ND sample results are typically used:

- ND value set equal to the method detection limit;
- ND value set equal to one-half of the method detection limit;
- ND value set equal to the sample detection limit;
- ND value set equal to one-half of the sample detection limit; and
- ND value set equal to zero (0).

EXAMPLE: Suppose a site analyzes two samples for benzo(a)pyrene. Benzo(a)pyrene is detected in the first sample at 100 ppb, but is not detected in the second sample. The analytical laboratory reports the second result as <50 ppb, where the method detection limit is 10 ppb and the sample detection limit is 50 ppb. Depending on which calculation method is used, the following averages could be calculated.

Result 1	Result 2	Method	Average
100 ppb	ND(50 ppb)	Used method detection limit (10 ppb)	55 ppb
100 ppb	ND(50 ppb)	Used one-half method detection limit (5 ppb)	52.5 ppb
100 ppb	ND(50 ppb)	Used sample detection limit (50 ppb)	75 ppb
100 ppb	ND(50 ppb)	Used one-half sample detection limit (25 ppb)	62.5 ppb
100 ppb	ND(50 ppb)	Used zero (0)	50 ppb

Use the following list of ND Calculation Method Codes to complete Questions 21(a) and 21(b).

ND Calculation Method Code	ND Calculation Method
ND-1	Used method detection limit
ND-2	Used one-half of the method detection limit
ND-3	Used sample detection limit
ND-4	Used one-half of the sample detection limit
ND-5	Used zero (0)
ND-6	Other (specify):

Submittal of Hard Copy

If you have any of the data requested in Questions 21(a) or 21(b) readily available in the requested format (see the question), you may attach it to the survey in lieu of responding to each question; write your site ID (shown on the cover page) and the question number on the upper right corner of each attachment. Indicate below whether you are submitting hard copies of the data requested in Questions 21(a) and 21(b) in lieu of filling out these questions.

Question	Hard Copy
21(a)	G
21(b)	G

21.(a)(2) What percentage of process wastewater at this permit monitoring location is from meat product operations?

G CBI

_____ Percentage

21.(b)(1) Has your site collected any data for any parameter from **NONPERMITTED MONITORING LOCATIONS** in this system by EPA-approved methods as described in 40 CFR Part 136 **during 1999?** **For purposes of this question, nonpermitted monitoring refers to monitoring for purposes other than permit compliance (e.g., internal process control monitoring locations, production or treatment unit process performance monitoring, etc.);** permit compliance monitoring data are requested in Question 21(a).

G CBI

Yes ¹G (Continue)

No ²G (Skip to Q.22)

(2) Indicate the type of data collected from nonpermitted monitoring locations in this system. Check () **ALL** that apply.

G CBI

Data collected to improve or monitor performance of the wastewater treatment system, or any unit operation in the wastewater treatment system, (e.g., to adjust chemical additions in a single unit operation) ¹G

Wastewater characterization analytical data collected from nonpermitted monitoring location(s) ²G

(3) Has your site collected any data for any parameter from nonpermitted monitoring locations in this system by EPA-approved methods as described in 40 CFR Part 136 **during 1997 or 1998?**

G CBI

Yes ¹G

No ²G

_____ %

22. In this section, describe environmental management or pollution prevention (waste reduction) practices. Examples include, but are not limited to:

G CBI

Collection of solids before clean up;
Dry clean up;
Draining/collecting residual product before cleaning;
Flow reduction nozzles;
Automatic flow shutoff valves;
Composting as disposal;
Nutrient reduction technologies and treatment systems;
Industrial eco-parks concept - EPA model; and
Water treatment and reuse system.

For each practice, try to include the following information:

- Affected processes and wastewater streams;
- Targeted process parameters (e.g. flow) and/or pollutants;
- Cost information (e.g., total cost of installation and implementation costs, net change in operating costs as a result of the practice); and
- Measurable results (e.g., pollutant reductions, flow reductions).

Please note that EPA is not soliciting detailed and voluminous design specifications and cost information, but instead desires general information related to the design and operation of environmental management or pollution prevention (waste reduction) practices that have been implemented at the site.

FINANCIAL INFORMATION

23. Please check the corporation type that best describes the company listed in Question 3 above.
G CBI

- Corporation © Corporation) ¹ G
 - Subchapter S Corporation/Limited Liability Corporation ² G
 - Limited partnership ³ G
 - General partnership ⁴ G
 - Sole proprietor ⁵ G
 - Other (specify) ⁶ G
-

24. Is the company listed in Question 3 above publicly or privately held?
G CBI

- Publicly held ¹ G
- Privately held ² G

25. For fiscal year 1999, list the average number of full-time equivalent (FTE) employees at the site and company (i.e., 2080 hr/yr). For example, four half-time employees would be listed as two full-time equivalent employees.

G CBI

- a. _____
Number of FTE employees at the site

- b. _____
Number of FTE employees at the company

26. Does this site typically operate on a single or double shift?

G CBI

Single shift ¹G

Double shift ²G

27. If the company borrows money to finance capital improvements, such as wastewater treatment equipment, what interest rate would it pay on such loans?

G CBI

___ __ __. __ %

Interest rate

28. What is the minimum rate of return on capital (i.e., the discount rate) required to compensate equity owners for bearing risk? Identify whether the rate is pre-tax or post-tax and whether the rate is real or nominal.

G CBI

___ __ __. __ %

Discount rate

Pre tax ¹G

or

Post tax ²G

Real rate ³G

or

Nominal ⁴G

29. When you finance capital improvements, what is the approximate mix of debt and equity?

G CBI

a. ___ __ __. __ %

Debt

b. ___ __ __. __ %

Equity

31. Income statement information (1997). For fiscal year 1997, complete the following income statement information. If the site is the company, check the box below and complete only the first column. If certain items are not held on the site's books, enter zero for the item under the site column. **Report amounts in dollars; round to the nearest thousand.**

G CBI

Single Site Company G

	Site	Company
REVENUES		
a. Net sales from meat products	\$_____,_____, <u>0 0 0</u>	\$_____,_____, <u>0 0 0</u>
b. Other income (such as equity earnings and interest)	\$_____,_____, <u>0 0 0</u>	\$_____,_____, <u>0 0 0</u>
c. Total revenues (sum of a and b)	\$_____,_____, <u>0 0 0</u>	\$_____,_____, <u>0 0 0</u>
COSTS AND EXPENSES		
d. Cost of goods sold (purchases and operating expenses)	\$_____,_____, <u>0 0 0</u>	\$_____,_____, <u>0 0 0</u>
e. Selling, general, administrative, depreciation and amortization expenses	\$_____,_____, <u>0 0 0</u>	\$_____,_____, <u>0 0 0</u>
f. Total costs and expenses (sum of d and e)	\$_____,_____, <u>0 0 0</u>	\$_____,_____, <u>0 0 0</u>
g. EARNINGS BEFORE INTEREST AND TAXES (EBIT) (subtract f from c)	\$_____,_____, <u>0 0 0</u>	\$_____,_____, <u>0 0 0</u>
h. INTEREST EXPENSE	\$_____,_____, <u>0 0 0</u>	\$_____,_____, <u>0 0 0</u>
i. TAXES	\$_____,_____, <u>0 0 0</u>	\$_____,_____, <u>0 0 0</u>
j. NET INCOME (subtract h and i from g)	\$_____,_____, <u>0 0 0</u>	\$_____,_____, <u>0 0 0</u>

32. Income statement information (1998). For fiscal year 1998, complete the following income statement information. If the site is the company, check the box below and complete only the first column. If certain items are not held on the site's books, enter zero for the item under the site column. **Report amounts in dollars; round to the nearest thousand.**

G CBI

Single Site Company G

	Site	Company
REVENUES		
a. Net sales from meat products	\$_____,_____, <u>0 0 0</u>	\$_____,_____, <u>0 0 0</u>
b. Other income (such as equity earnings and interest)	\$_____,_____, <u>0 0 0</u>	\$_____,_____, <u>0 0 0</u>
c. Total revenues (sum of a and b)	\$_____,_____, <u>0 0 0</u>	\$_____,_____, <u>0 0 0</u>
COSTS AND EXPENSES		
d. Cost of goods sold (purchases and operating expenses)	\$_____,_____, <u>0 0 0</u>	\$_____,_____, <u>0 0 0</u>
e. Selling, general, administrative, depreciation and amortization expenses	\$_____,_____, <u>0 0 0</u>	\$_____,_____, <u>0 0 0</u>
f. Total costs and expenses (sum of d and e)	\$_____,_____, <u>0 0 0</u>	\$_____,_____, <u>0 0 0</u>
g. EARNINGS BEFORE INTEREST AND TAXES (EBIT) (subtract f from c)	\$_____,_____, <u>0 0 0</u>	\$_____,_____, <u>0 0 0</u>
h. INTEREST EXPENSE	\$_____,_____, <u>0 0 0</u>	\$_____,_____, <u>0 0 0</u>
i. TAXES	\$_____,_____, <u>0 0 0</u>	\$_____,_____, <u>0 0 0</u>
j. NET INCOME (subtract h and i from g)	\$_____,_____, <u>0 0 0</u>	\$_____,_____, <u>0 0 0</u>

33. Income statement information (1999). For fiscal year 1999, complete the following income statement information. If the site is the company, check the box below and complete only the first column. If certain items are not held on the site's books, enter zero for the item under the site column. **Report amounts in dollars; round to the nearest thousand.**

G CBI

Single Site Company G

	Site	Company
REVENUES		
a. Net sales from meat products	\$_____,_____, <u>0 0 0</u>	\$_____,_____, <u>0 0 0</u>
b. Other income (such as equity earnings and interest)	\$_____,_____, <u>0 0 0</u>	\$_____,_____, <u>0 0 0</u>
c. Total revenues (sum of a and b)	\$_____,_____, <u>0 0 0</u>	\$_____,_____, <u>0 0 0</u>
COSTS AND EXPENSES		
d. Cost of goods sold (purchases and operating expenses)	\$_____,_____, <u>0 0 0</u>	\$_____,_____, <u>0 0 0</u>
e. Selling, general, administrative, depreciation and amortization expenses	\$_____,_____, <u>0 0 0</u>	\$_____,_____, <u>0 0 0</u>
f. Total costs and expenses (sum of d and e)	\$_____,_____, <u>0 0 0</u>	\$_____,_____, <u>0 0 0</u>
g. EARNINGS BEFORE INTEREST AND TAXES (EBIT) (subtract f from c)	\$_____,_____, <u>0 0 0</u>	\$_____,_____, <u>0 0 0</u>
h. INTEREST EXPENSE	\$_____,_____, <u>0 0 0</u>	\$_____,_____, <u>0 0 0</u>
i. TAXES	\$_____,_____, <u>0 0 0</u>	\$_____,_____, <u>0 0 0</u>
j. NET INCOME (subtract h and i from g)	\$_____,_____, <u>0 0 0</u>	\$_____,_____, <u>0 0 0</u>

34. Balance sheet information (1999). For fiscal year 1999, complete the following balance sheet information. If the site is the company, check the box below and complete only the first column. If certain items are not held on the site's books, enter zero for the item under the site column. **Report amounts in dollars; round to the nearest thousand.**

G CBI

Single Site Company G

	Site	Company
ASSETS		
a. Current assets, excluding inventories	\$____,____,0 0 0	\$____,____,0 0 0
b. Inventories	\$____,____,0 0 0	\$____,____,0 0 0
c. Land (original cost)	\$____,____,0 0 0	\$____,____,0 0 0
d. Buildings (original cost)	\$____,____,0 0 0	\$____,____,0 0 0
e. Equipment (original cost)	\$____,____,0 0 0	\$____,____,0 0 0
f. Other noncurrent assets (original cost)	\$____,____,0 0 0	\$____,____,0 0 0
g. Cumulative depreciation	\$____,____,0 0 0	\$____,____,0 0 0
h. Total assets (sum of a through f minus g)	\$____,____,0 0 0	\$____,____,0 0 0
LIABILITIES AND EQUITY		
i. Current liabilities (including accounts payable, accrued expenses and taxes, and the current portion of long-term debt)	\$____,____,0 0 0	\$____,____,0 0 0
j. Long-term debt (including bonds, debentures, long-term leases, bank debt, and all other noncurrent liabilities such as deferred income taxes)	\$____,____,0 0 0	\$____,____,0 0 0
k. Retained earnings	\$____,____,0 0 0	\$____,____,0 0 0
l. Owner equity (other than retained earnings)	\$____,____,0 0 0	\$____,____,0 0 0
m. Total liabilities and equity (sum of l through l)	\$____,____,0 0 0	\$____,____,0 0 0

COPY # ___ of ___

-
- 35.** Include a copy of the company's end-of-year financial statements for 1999 with the completed questionnaire. These may be accountant reports, annual reports, and/or 10-K forms, and **MUST** include both an income statement and balance sheets for the company. These statements need not be audited, but should conform to generally accepted accounting principles (GAAP). In all cases, **INCLUDE THE NOTES TO THE FINANCIAL STATEMENTS.** You may claim the information as confidential by marking the document(s) with the word "Confidential," or by checking the global CBI box on page ii.

APPENDIX A

**1987 STANDARD INDUSTRIAL CLASSIFICATION (SIC) CODES MATCHED TO 1997 NORTH AMERICAN
INDUSTRY CLASSIFICATION SYSTEM (NAICS) CODES**

APPENDIX A. 1987 Standard Industrial Classification (SIC) Codes Matched to 1997 North American Industry Classification System (NAICS) Codes

1987 SIC Code	1987 SIC Description	1997 NAICS Code	1997 NAICS Description
0254	Poultry Hatcheries	11234	Poultry Hatcheries
0751	Livestock Services, Except Veterinary		
	Custom Slaughtering	311611	Animal (Except Poultry) Slaughtering (pt)
	Other Livestock Service, Except Veterinary	11521	Support Activities for Animal Production (pt)
2011	Meat Packing Plants	311611	Animal (Except Poultry) Slaughtering (pt)
2013	Sausages and Other Prepared Meats	311612	Meat Processed from Carcasses (pt)
2015	Poultry Slaughtering and Processing		
	Poultry Processing	311615	Poultry Processing
	Egg Processing	311999	All Other Miscellaneous Food Manufacturing (pt)
2047	Dog and Cat Food	311111	Dog and Cat Food Manufacturing
2048	Prepared Feed and Feed Ingredients for Animals and Fowls, Except Dogs and Cats		
	Animal Slaughtering for Pet Food	311611	Animal (Except Poultry) Slaughtering (pt)
	Except Slaughtering Animals for Pet Food	311119	Other Animal Food Manufacturing
2077	Animal and Marine Fats and Oils		
	Animal Fats and Oils	311613	Rendering and Meat By-Product Processing
	Canned Marine Fats and Oils	311711	Seafood Canning (pt)

1987 SIC Code	1987 SIC Description	1997 NAICS Code	1997 NAICS Description
	Fresh and Frozen Marine Fats and Oils	311712	Fresh and Frozen Seafood Processing (pt)
	Vegetable Oil Foods	311225	Fats and Oils Refining and Blending (pt)
2079	Shortening, Table Oils, Margarine, and Other Edible Fats and Oils, NEC		
	Processing Fats and Oils from Purchased Fats and Oils	311225	Fats and Oils Refining and Blending (pt)
	Processing Soybean Oil from Soybeans Crushed in the Same Establishment	311222	Soybean Processing (pt)
	Processing Vegetable Oils, except Soybeans, from Oilseeds Crushed in the Same Establishment	311223	Other Oilseed Processing (pt)
3111	Leather Tanning and Finishing	31611	Leather and Hide Tanning and Finishing (pt)

The abbreviation "pt" means "part of."

The abbreviation NEC is used for Not Elsewhere Classified.

APPENDIX B
PROCESS FLOW DIAGRAMS

Example Poultry Production Process Diagram

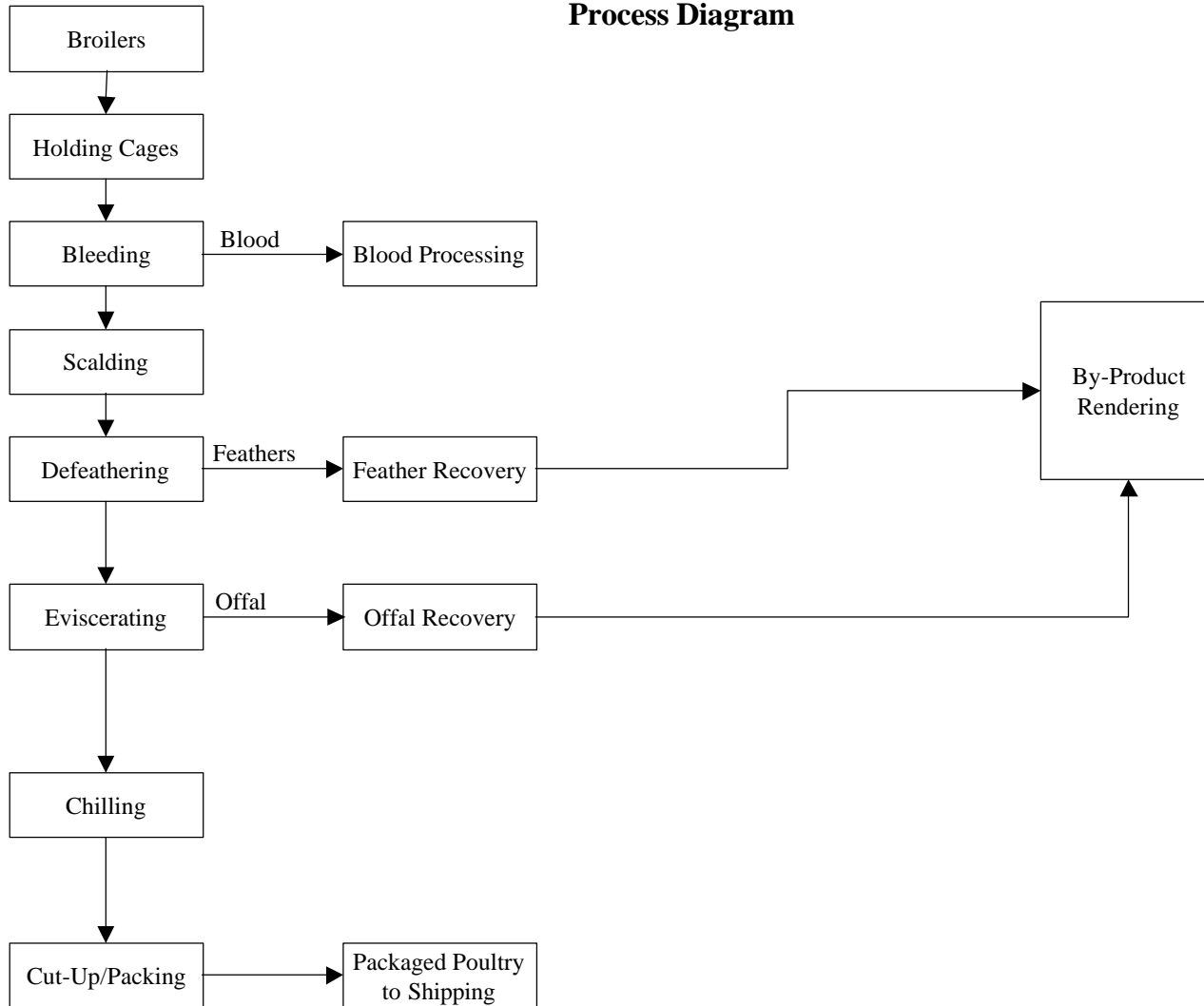

Example First Processing Wastewater Flow Diagram

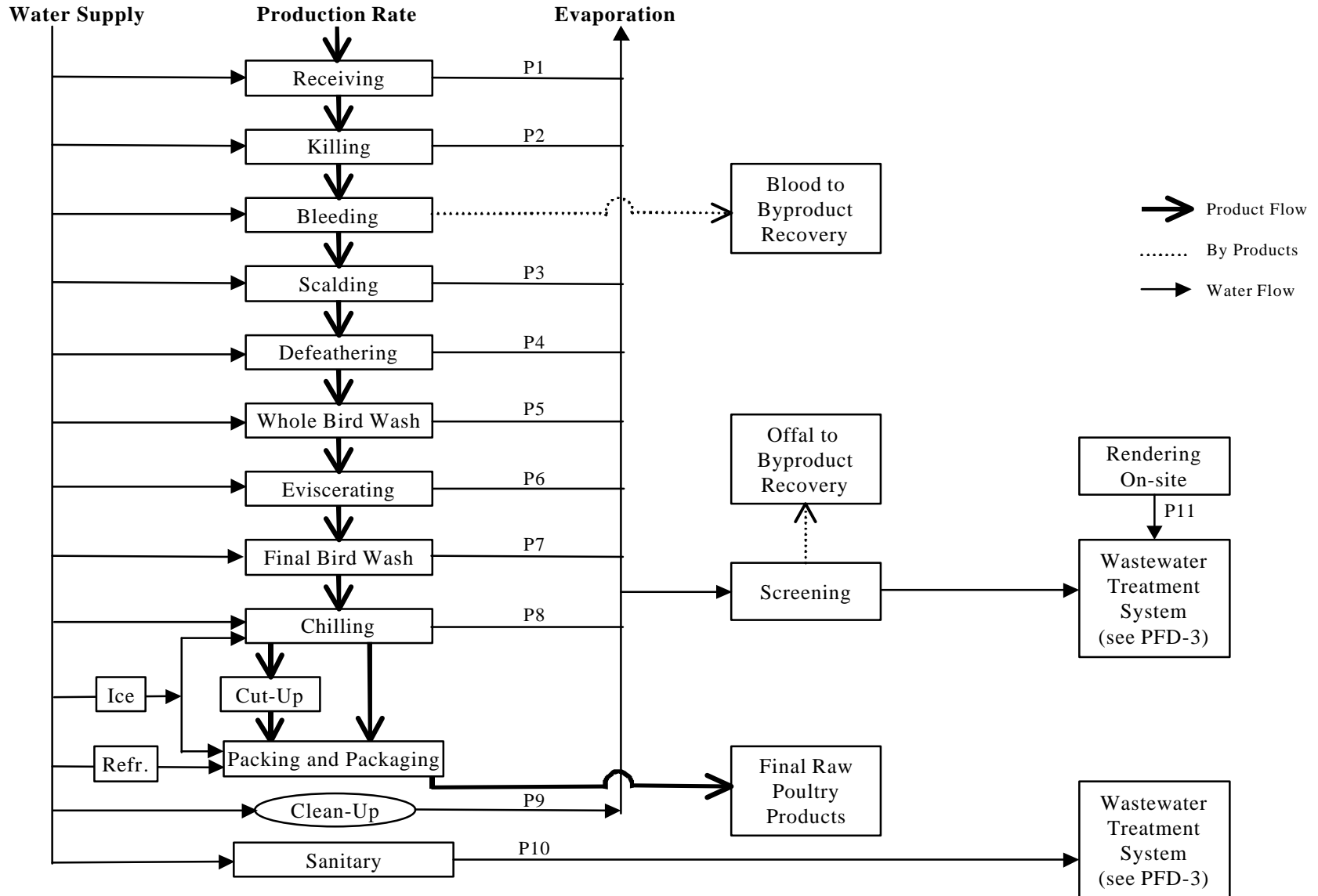

Example Poultry Processing Wastewater Flow Diagram

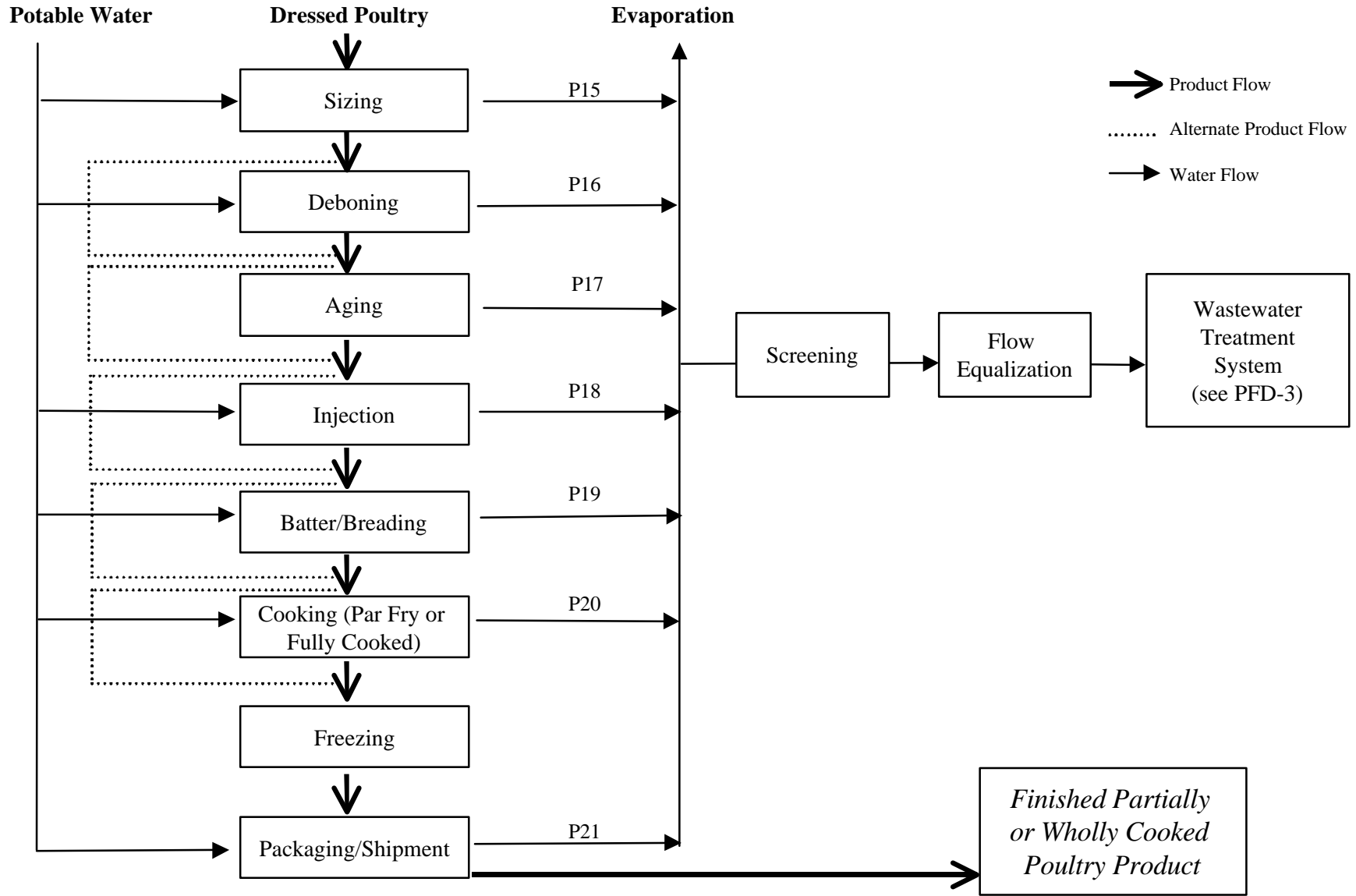

Example Rendering or Byproduct Processing Wastewater Flow Diagram

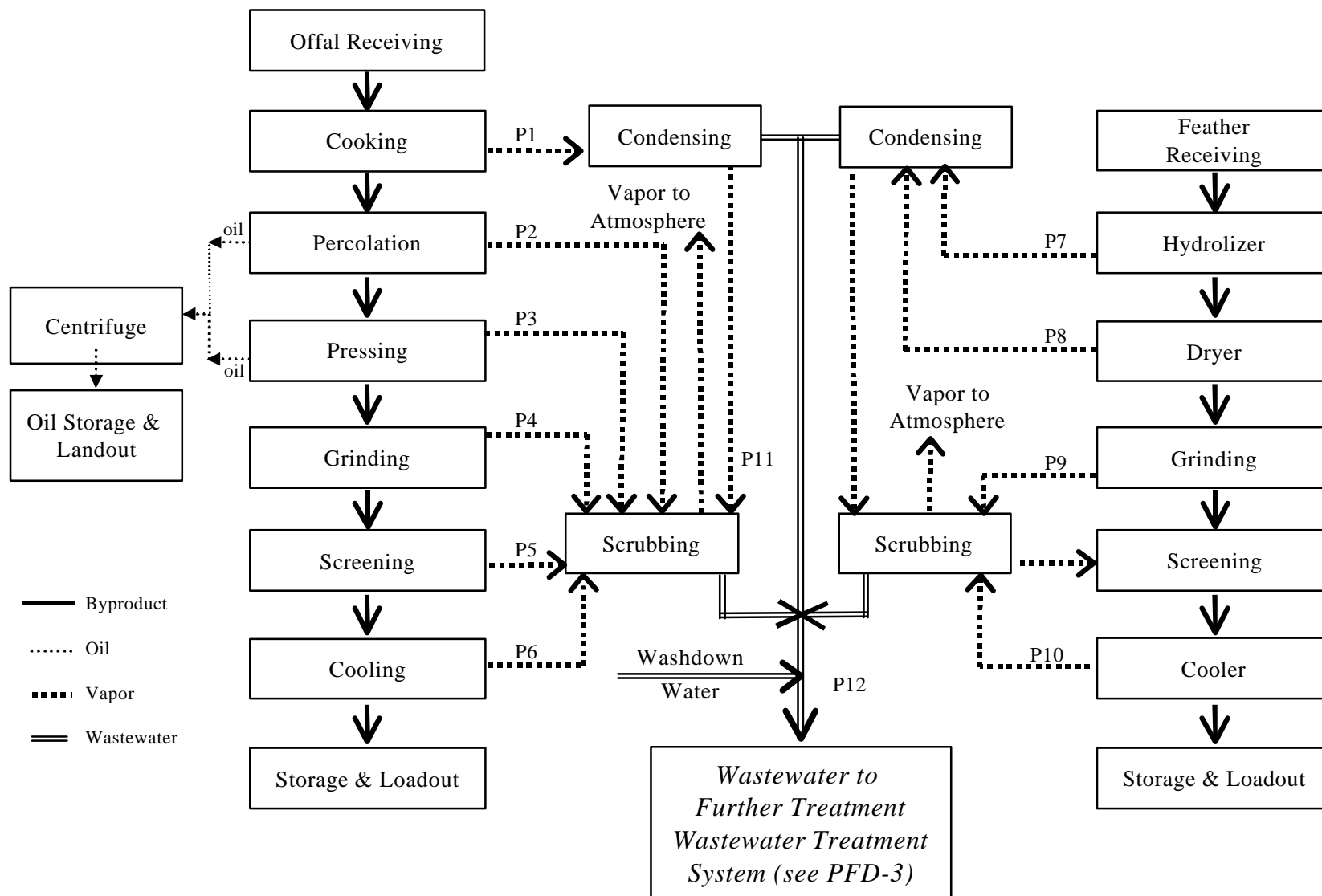

Example Poultry Processing Wastewater Treatment System

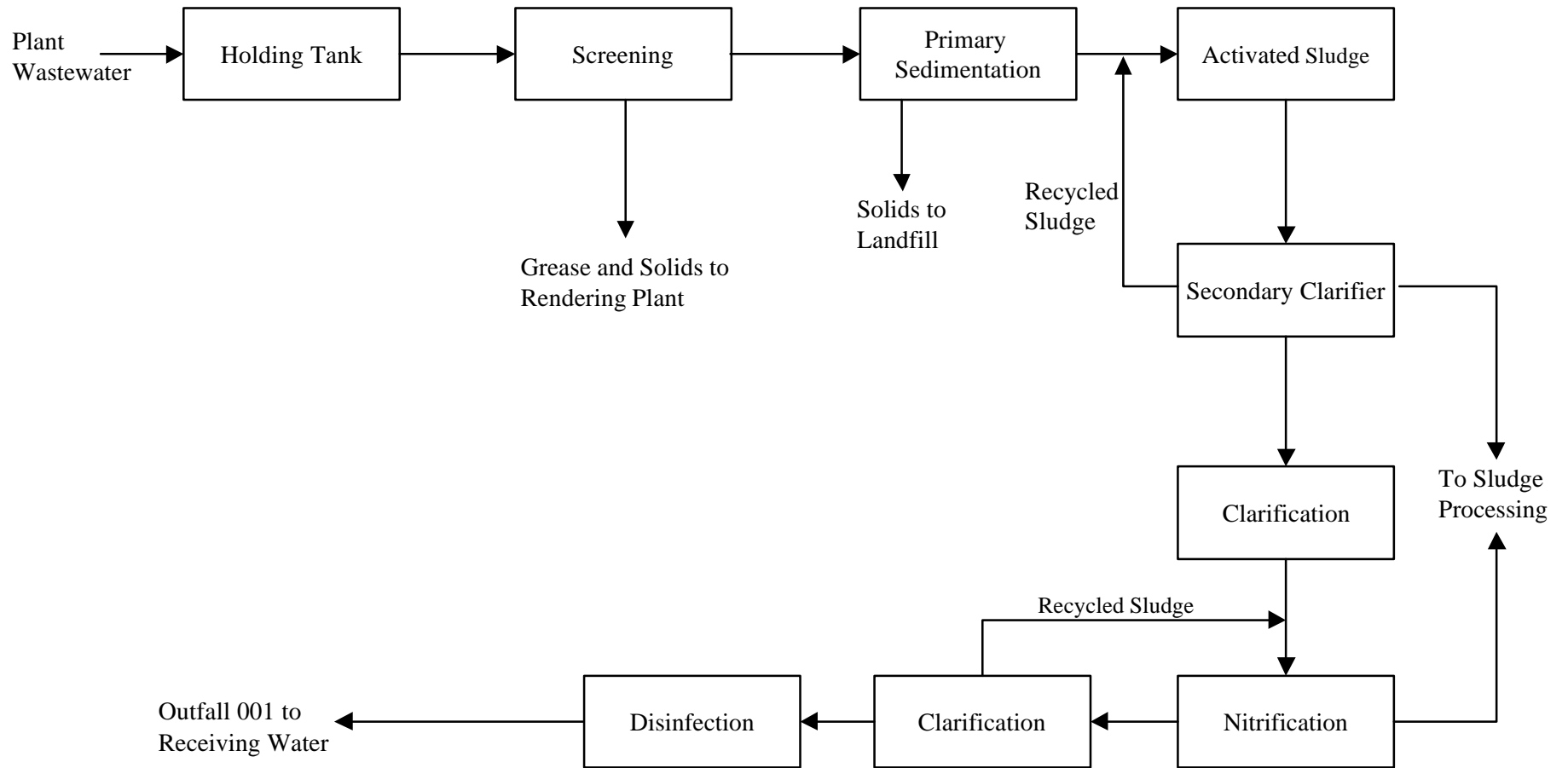

Example Red Meat Production Process Diagram

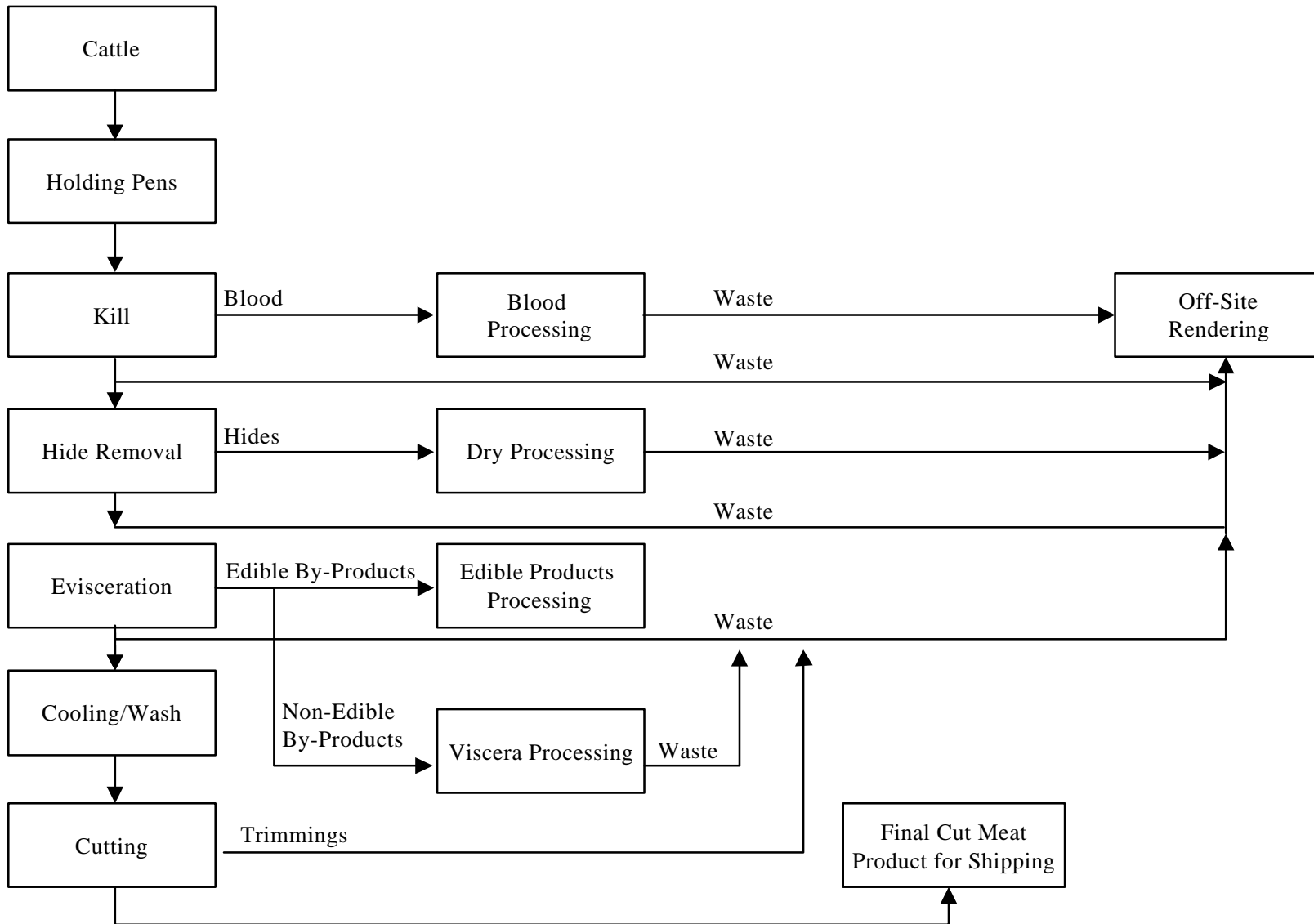

Example Red Meat Processing Wastewater Flow Diagram

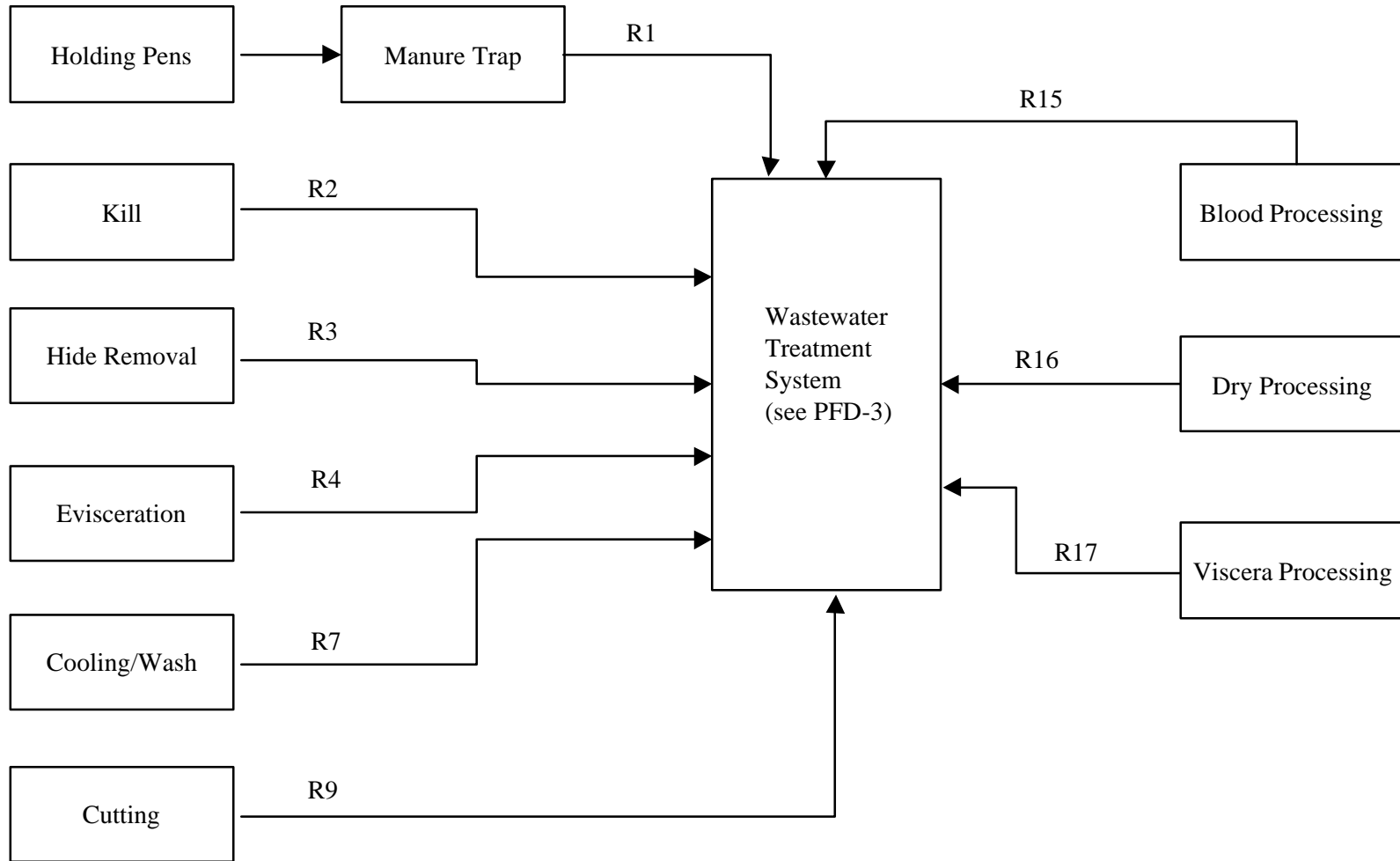

Example Red Meat Processing Wastewater Treatment System

